



**Thermo Scientific**

# **TriPlus RSH**

Robotic Sample Handling

## **Preinstallation Requirements Guide**

P/N 31709610, Sixth Edition, October 2013

© 2013 Thermo Fisher Scientific Inc. All rights reserved.  
TriPlus RSH, TRACE GC Ultra, FOCUS GC, ISQ, ITQ, DSQ II and TSQ are trademarks of Thermo Fisher Scientific Inc., and its subsidiaries.

Published by Thermo Fisher Scientific S.p.A., Strada Rivoltana 20090 Rodano-Milan, Italy  
Tel: +39 02 95059303; Fax: +39 02 95059388

Thermo Fisher Scientific Inc. provides this document to its customers with a product purchase to use in the product operation. This document is copyright protected and any reproduction of the whole or any part of this document is strictly prohibited, except with the written authorization of Thermo Fisher Scientific Inc.

The contents of this document are subject to change without notice. All technical information in this document is for reference purposes only. System configurations and specifications in this document supersede all previous information received by the purchaser.

**Thermo Fisher Scientific Inc. makes no representations that this document is complete, accurate or error-free and assumes no responsibility and will not be liable for any errors, omissions, damage or loss that might result from any use of this document, even if the information in the document is followed properly.**

This document is not part of any sales contract between Thermo Fisher Scientific Inc. and a purchaser. This document shall in no way govern or modify any Terms and Conditions of Sale, which Terms and Conditions of Sale shall govern all conflicting information between the two documents.

Release history:

First edition, released September 2011 "*Original Instructions*"

Second edition, released December 2011

Third Edition, released March 2012

Fourth Edition, released September 2012

Fifth Edition, released March 2013

Sixth Edition, released October 2013

**For Research Use Only. Not for use in diagnostic procedures.**



# TriPlus RSH Installation Request Form

Once you read the TriPlus RSH Preinstallation Requirements Guide, print and complete this form. After all the requirements on this form are fulfilled, sign and date the form. Then mail or fax this form to your local ThermoFisher Scientific sales/service office.

### Requirements Checklist

- All laboratory remodeling has been completed.
- Your TriPlus RSH is on site.
- Principal operator will be available during the installation / certification period.
- Doorways, hallways, etc. are a minimum width of 80 cm (32 in.).
- Available floor area is sufficient and flooring will support the mass of the system.
- Available workbench is sufficient for all of the equipment. List the bench measurements:  
Width:  
Depth:  
Height:
- Workbench can support the mass of the system [107 kg (236 lbs)] and is free from vibration.
- Lighting is adequate.
- Main power is installed and is in compliance with local electrical codes.
- Power outlets are of the correct configuration. NEMA type: \_\_\_\_\_
- The power outlets are enough for the electrical connections.
- Voltage of power outlet has been measured. Measured voltage: \_\_\_\_\_
- Power is free from fluctuations due to slow changes in the average voltage or changes due to surges, sags, or transients.
- One or more RJ-45 wall outlet. To connect your system to your site's LAN network, you must have an additional shielded twisted pair network cable.
- Air conditioning is adequate for temperature, humidity, and particulate matter control. The laboratory can be maintained at a constant temperature, between 15 and 27 °C (59 and 81 °F).
- Relative humidity is between 40% and 80% with no condensation.
- Air in your laboratory is free of excessive dust, smoke or other particulate matter.
- Work area is free from magnetic disruption and electrostatic discharge.
- One voice telephone line is installed near the system.

### Principal Operator Level of Experience

- |                                      |                                      |                                   |                                  |
|--------------------------------------|--------------------------------------|-----------------------------------|----------------------------------|
| GC, Injector and Column Knowledge:   | <input type="checkbox"/> Experienced | <input type="checkbox"/> Moderate | <input type="checkbox"/> Limited |
| Gas Chromatography Theory Knowledge: | <input type="checkbox"/> Experienced | <input type="checkbox"/> Moderate | <input type="checkbox"/> Limited |
| Data System Knowledge:               | <input type="checkbox"/> Experienced | <input type="checkbox"/> Moderate | <input type="checkbox"/> Limited |

### Additional Information

- Have any special acceptance specifications been agreed to in the contract? Yes  No
- If Yes, attach full details of specifications.
- Is there any additional equipment that needs to be interfaced to the system? Yes  No
- If Yes, attach full details of additional equipment.

**Note** We reserve the right to invoice you for the Field Service Engineer's time if the installation requirements are not met on the date of the installation. To avoid any additional cost, please ensure your site is properly prepared.

Fill in the information below (please print clearly):

Name \_\_\_\_\_

Company \_\_\_\_\_ Telephone \_\_\_\_\_

Address \_\_\_\_\_

Address \_\_\_\_\_

City \_\_\_\_\_ State \_\_\_\_\_ Country \_\_\_\_\_

Signature \_\_\_\_\_ Date \_\_\_\_\_



# Service Offices for Thermo Scientific CMD Products

## North America

### United States

1400 North Point Pkwy # 10

West Palm Beach, FL 33407

E-mail:

[us.customer-support.analyze@thermofisher.com](mailto:us.customer-support.analyze@thermofisher.com)

Phone .....[1] (732) 627-0220

Fax .....[1] (732) 627-0260

### Canada

2845 Argentia Road, Unit 4

Mississauga, Ontario, L5N 8G6

E-mail:

[us.customer-support.analyze@thermofisher.com](mailto:us.customer-support.analyze@thermofisher.com)

Phone .....[1] 800 530 8447

Fax .....[1] (905) 890-9161

## Europe

### Austria

Wehlstrasse 27b

A-1200 Wien

E-mail: [service.sid.austria@thermofisher.com](mailto:service.sid.austria@thermofisher.com)

Phone .....[43] (0) 1 333 50 34-0

Fax .....[43] (0) 1 333 50 34-26

### Belgium

Clintonpark "Keppekouter"

Nonovesteenweg 198

B-9320 Erembodegem - Aalst

E-mail: [service.sid.benelux@thermofisher.com](mailto:service.sid.benelux@thermofisher.com)

Phone .....[32] (0) 2 482 3030

Fax .....[32] (0) 2 482 3031

### Denmark

Fruebjergvej 3

2100 København Ø

Email: [service.sid.dk@thermofisher.com](mailto:service.sid.dk@thermofisher.com)

Denmark

Phone .....[45] (70) 236 267

Fax .....[45] (70) 236 263

### France

(also representing French speaking N. Africa, Algeria, Morocco, and Tunisia)

16 Avenue du Québec

Silic 765

Z.A. de Courtaboeuf

F-91963 Les Ulis Cédex

E-mail: [servicesid.lesulis@thermofisher.com](mailto:servicesid.lesulis@thermofisher.com)

Phone .....[33] (01) 60 92 48 00

Fax .....[33] (01) 60 92 49 00

### Germany

Im Steingrund 4-6

D-63303 Dreieich

E-mail: [service.dreieich@thermofisher.com](mailto:service.dreieich@thermofisher.com)

Phone .....[49] (0) 6103 408 1050

Fax .....[49] (0) 6103 408 1213

### Italy

Strada Rivoltana

I-20090 Rodano (Milano)

E-mail: [assistenza.tecnica.it@thermofisher.com](mailto:assistenza.tecnica.it@thermofisher.com)

Phone .....Numero Verde (800) 823 162

Fax .....[39] (02) 95320 225

**Notes:** The country code is enclosed in square brackets [ ]. The city code or area code is enclosed in parenthesis ( ). For countries other than the U.S.A., when you are dialing from within the specified country, dial the 0 of the city code. For countries other than Italy, when you are dialing from outside the country, do not dial the 0 of the city code.

# Offices for Thermo Scientific CMD Products—Continued

## Europe—continued

### Netherlands

Takkebijsters 1  
NL-4817 BL Breda  
E-mail: [service.sid.benelux@thermofisher.com](mailto:service.sid.benelux@thermofisher.com)  
Phone .....[31] (0) 76 579 55 55  
Fax .....[31] (0) 76 581 09 61

### Spain

C/Valportillo I, N°22 1a Planta  
Edificio Caoba  
ES-28108 Alcobendas - Madrid  
Email: [service.sid.spain@thermofisher.com](mailto:service.sid.spain@thermofisher.com)  
Phone .....[34] (0914) 845 965  
Fax .....[34] (0914) 843 598

### Sweden

Pyramidbacken 3  
S-141 75 Kungens Kurva (Stockholm)  
E-mail: [service.sid.nordic@thermofisher.com](mailto:service.sid.nordic@thermofisher.com)  
Phone .....[46] (08) 556 468 00  
Fax .....[46] (08) 556 468 08

### Switzerland

Neuhofstrasse 11  
4153 Reinach  
E-mail: [service.sid.ch@thermofisher.com](mailto:service.sid.ch@thermofisher.com)  
Phone .....[41] (617) 16 77 40  
Fax .....[41] (617) 16 77 20

### United Kingdom

Stafford House  
1 Boundary Park  
Boundary Way  
Hemel Hempstead  
Hertfordshire HP2 7GE  
E-mail: [service.sid.hemel@thermofisher.com](mailto:service.sid.hemel@thermofisher.com)  
Phone .....[44] (0) 870 241 1034  
Fax .....[44] (0) 1442 233 667

## Australia and Asia

### Australia

P.O. Box 9092  
5 Caribbean Drive  
Scoresby, VIC 3179  
E-mail: [analyze.au@thermofisher.com](mailto:analyze.au@thermofisher.com)  
Phone .....[61] (02) 9898-9000  
Fax .....[61] (02) 9898-9800

### Japan

C-2F  
3-9 Moriya-cho, Kanagawa-ku  
Yokohama 221-0022  
E-mail: [analyze.jp@thermofisher.com](mailto:analyze.jp@thermofisher.com)  
Phone .....[81] (45) 453-9100  
Fax .....[81] (06) 453-9110

### P.R. China

Building 6,  
No. 27 Xin Jinqiao Road  
Pudong Export Zone  
Shanghai 201206  
E-mail: [analyze.cn@thermofisher.com](mailto:analyze.cn@thermofisher.com)  
Phone (free lines) .....800 810 5118, 400 650 5118

### P.R. China

7th Floor, 7F Tower West, Younghe Plaza  
No. 28 Andingmen East Street  
Beijing 100007  
E-mail: [analyze.cn@thermofisher.com](mailto:analyze.cn@thermofisher.com)  
Phone (free lines) .....800 810 5118, 400 650 5118  
Fax .....[86] (10) 88370548

## Declaration

Manufacturer: **Thermo Fisher Scientific**

Thermo Fisher Scientific is the manufacturer of the instrument described in this manual and, as such, is responsible for the instrument safety, reliability and performance only if:

- installation
- re-calibration
- changes and repairs

have been carried out by authorized personnel and if:

- the local installation complies with local law regulations
- the instrument is used according to the instructions provided and if its operation is only entrusted to qualified trained personnel

Thermo Fisher Scientific is not liable for any damages derived from the non-compliance with the aforementioned recommendations.

## Regulatory Compliance

Thermo Fisher Scientific performs complete testing and evaluation of its products to ensure full compliance with applicable domestic and international regulations.

Thermo Fisher Scientific declares, under sole responsibility, that the product as originally delivered complies with the requirements of the following applicable European Directives and carries the CE marking accordingly:

- Low Voltage Directive:2006/95/EC
- EMC Directive:2004/108/EC
- Machinery Directive: 2006/42/EC

... and conforms with the following product standards:

### Safety

This device complies with>

- ANSI/UL 61010-1:2004 2nd Edition, CAN/CSA C22.2 No. 61010-1:2004 2nd Edition.
- EN 61010-2-010:2003 | EN 61010-2-051:2003 | EN 61010-2-081:2001+A1:2003

### Electromagnetic Compatibility

This device complies with:

- EN 61326-1:2006 / IEC 61326-1:2005
- EN 61000-6-2:2005 / IEC 61000-6-2:2005 | EN 61000-6-3:2007 / IEC 61000-6-3:2006

### Laser Class 1

The selected Class 1 Laser for the TriPlus RSH module Barcode Reader complies with the following regulations:

- 21 CFR1040.10 and 1040.11 except for deviations pursuant to Laser Notice No. 50, dated July 26, 2001
- EN60825-1:1994 + A1:2002 + A2:2001
- IEC60825-1:1993 + A1:1997 + A2:2001

## FCC Compliance Statement

THIS DEVICE COMPLIES WITH PART 15 OF THE FCC RULES. OPERATION IS SUBJECT TO THE FOLLOWING TWO CONDITIONS: (1) THIS DEVICE MAY NOT CAUSE HARMFUL INTERFERENCE, AND (2) THIS DEVICE MUST ACCEPT ANY INTERFERENCE RECEIVED, INCLUDING INTERFERENCE THAT MAY CAUSE UNDESIRE OPERATION.



**CAUTION** Read and understand the various precautionary notes, signs, and symbols contained inside this manual pertaining to the safe use and operation of this product before using the device.

### Notice on Lifting and Handling of Thermo Scientific Instruments

For your safety, and in compliance with international regulations, the physical handling of this Thermo Fisher Scientific instrument *requires a team effort* to lift and/or move the instrument. This instrument is too heavy and/or bulky for one person alone to handle safely.

### Notice on the Proper Use of Thermo Scientific Instruments

In compliance with international regulations: Use of this instrument in a manner not specified by Thermo Fisher Scientific could impair any protection provided by the instrument.

### Notice on the Susceptibility to Electromagnetic Transmissions

Your instrument is designed to work in a controlled electromagnetic environment. Do not use radio frequency transmitters, such as mobile phones, in close proximity to the instrument. For manufacturing location, see the label on the instrument.



## WEEE Compliance

This product is required to comply with the European Union's Waste Electrical & Electronic Equipment (WEEE) Directive 2002/96/EC. It is marked with the following symbol:



Thermo Fisher Scientific has contracted with one or more recycling or disposal companies in each European Union (EU) Member State, and these companies should dispose of or recycle this product. See [www.thermoscientific.com/rohswcee](http://www.thermoscientific.com/rohswcee) for further information on Thermo Fisher Scientific's compliance with these Directives and the recyclers in your country.

## WEEE Konformität

Dieses Produkt muss die EU Waste Electrical & Electronic Equipment (WEEE) Richtlinie 2002/96/EC erfüllen. Das Produkt ist durch folgendes Symbol gekennzeichnet:



Thermo Fisher Scientific hat Vereinbarungen mit Verwertungs-/Entsorgungsfirmen in allen EU-Mitgliedsstaaten getroffen, damit dieses Produkt durch diese Firmen wiederverwertet oder entsorgt werden kann. Mehr Information über die Einhaltung dieser Anweisungen durch Thermo Fisher Scientific, über die Verwerter, und weitere Hinweise, die nützlich sind, um die Produkte zu identifizieren, die unter diese RoHS Anweisung fallen, finden sie unter [www.thermoscientific.com/rohswcee](http://www.thermoscientific.com/rohswcee).

## Conformité DEEE

Ce produit doit être conforme à la directive européenne (2002/96/EC) des Déchets d'Equipements Electriques et Electroniques (DEEE). Il est marqué par le symbole suivant:



Thermo Fisher Scientific s'est associé avec une ou plusieurs compagnies de recyclage dans chaque état membre de l'union européenne et ce produit devrait être collecté ou recyclé par celles-ci. Davantage d'informations sur la conformité de Thermo Fisher Scientific à ces directives, les recycleurs dans votre pays et les informations sur les produits Thermo Fisher Scientific qui peuvent aider la détection des substances sujettes à la directive RoHS sont disponibles sur [www.thermoscientific.com/rohswcee](http://www.thermoscientific.com/rohswcee).

## Conformità RAEE

Questo prodotto è marcato con il seguente simbolo in conformità alla direttiva europea 2002/96/CE (RAEE) sui rifiuti di apparecchiature elettriche ed elettroniche:



Thermo Fisher Scientific si è accordata con una o più società di riciclaggio in ciascun Stato Membro della Unione Europea (EU), e queste società dovranno smaltire o riciclare questo prodotto. Per maggiori informazioni vedere il sito [www.thermoscientific.com/rohsweee](http://www.thermoscientific.com/rohsweee).

## Conformidad RAEE

Este producto es marcado con el siguiente símbolo en conformidad a la Directiva 2002/96/CE de la Unión Europea sobre los residuos de aparatos eléctricos y electrónicos:



Thermo Fisher Scientific ha contratado una o más empresas de reciclaje para tratar residuos en cada Estado Miembro de la Unión Europea, y estas empresas deberían reciclar o eliminar este producto. Referirse a [www.thermoscientific.com/rohsweee](http://www.thermoscientific.com/rohsweee) para una mayor información sobre la conformidad de Thermo Fisher Scientific con estas Directivas y para las empresas de reciclaje en su país.



### IMPORTANT

The symbol indicates the product must not be disposed of with the normal household wastes. Correct disposal of this product prevents any potentially negative impact on the environmental and human health that could arise from any inappropriate handling of the product itself.

WEEE and RoHS rules, while laid down at European level, are put into national law at national level. When exporting to Europe, it is essential to comply with national law in each relevant country. The EU law simply serves as a template for national laws, which may differ considerably.

Each EU Member State has own regulations regarding the application of these directives. Please refer to the regulations in force in your country.

# Contents

<b>Preface</b> .....	<b>.xiii</b>
About Your System .....	.xiii
Power Rating .....	.xiii
Contacting Us .....	.xiii
Related Documentation .....	.xiv
Safety Alerts and Important Information .....	.xiv
Special Notices .....	.xiv
Safety Symbols and Signal Words .....	.xiv
Instrument Markings and Symbols .....	.xvi
Safety Information and Warnings .....	.xvii
General Considerations .....	.xvii
Electrical Hazards .....	.xviii
Laser Safety Information .....	.xix
Other Hazards .....	.xx
Working with Toxic or other Harmful Compounds .....	.xxi
Biological Hazards .....	.xxii
Maintenance .....	.xxii
Disposal .....	.xxiii
<b>Chapter 1 TriPlus RSH Site Preparation</b> .....	<b>.1</b>
Writing Conventions for TriPlus RSH .....	.2
Entrance Requirements .....	.2
Space and Load Requirements .....	.3
GC System + TriPlus RSH Configuration .....	.4
GC System + TriPlus RSH Configuration Space and Mass Requirements .....	.6
Power Requirements .....	.8
Power Line .....	.8
Power Module .....	.8
Electrical Specifications .....	.9
Environment Requirements .....	.10
Environmental Conditions .....	.10
Gas Equipment Requirements .....	.12
LAN Network Requirements .....	.12
Receiving Instruments .....	.12
What Happens Next? .....	.13



## Preface

This guide contains preinstallation requirements that must be in compliance before installing the TriPlus RSH (Robotic Sample Handling) integrated sampling system.

## About Your System

Thermo Fisher Scientific systems operate safely and reliably under carefully controlled environmental conditions. If the equipment is used in a manner not specified by the manufacturer, the protections provided by the equipment might be impaired. If you maintain a system outside the specifications listed in this guide, failures of many types, including personal injury or death, might occur. The repair of instrument failures caused by operation in a manner not specified by the manufacturer is specifically excluded from the Standard Warranty and service contract coverage.

## Power Rating

TriPlus RSH:

100/240 Vac +/-10%; 50/60 Hz; 5 A max; 200 VA (400 VA when two Power Modules are required).

Detailed instrument specifications are in the Product Specification or Product Brochure.

## Contacting Us

Thermo Fisher Scientific provides comprehensive technical assistance worldwide and is dedicated to the quality of our customer relationships and services.

Use <http://www.thermoscientific.com> address for products information.

Use <http://www.gc-gcms-customersupport.com/WebPage/Share/Default.aspx> address to contact your local Thermo Fisher Scientific office, or affiliate GC-GC/MS Customer Support.

## Related Documentation

In addition to this guide, Thermo Scientific provides the following documents for the TriPlus RSH.

- *TriPlus RSH Safety Guide*, PN 31709600
- *TriPlus RSH Preinstallation Requirements Guide*, PN 31709610
- *TriPlus RSH User Guide*, PN 31709620
- *TriPlus RSH Hardware Manual*, PN 31709640

To suggest ways we can improve the documentation, follow this link to complete our [documentation survey](#).

## Safety Alerts and Important Information

Make sure you follow the precautionary notices presented in this manual. The safety and other special notices appear in boxes.

### Special Notices

Notices includes the following:







**IMPORTANT** Highlights information necessary to prevent damage to software, loss of data, or invalid test results; or might contain information that is critical for optimal performance of the system.

**Note** Emphasizes important information about a task.

**Tip** Helpful information that can make a task easier.

## Safety Symbols and Signal Words

All safety symbols are followed by **WARNING** or **CAUTION**, which indicates the degree of risk for personal injury, instrument damage, or both. Cautions and warnings are following by a descriptor, such as **BURN HAZARD**. A **WARNING** is intended to prevent improper actions that could cause personal injury. Whereas, a **CAUTION** is intended to prevent improper actions that might cause personal injury, instrument damage, or both. You can find the following safety symbols on your instrument, or in this guide:

Symbol	Descriptor
	<b>BIOHAZARD:</b> Indicates that a biohazard <i>will, could, or might</i> occur.
	<b>BURN HAZARD:</b> Alerts you to the presence of a hot surface that <i>could or might</i> cause burn injuries.
	<b>ELECTRICAL SHOCK HAZARD:</b> Indicates that an electrical shock <i>could or might</i> occur.
	<b>FIRE HAZARD:</b> Indicates a risk of fire or flammability <i>could or might</i> occur.
	<b>EXPLOSION HAZARD.</b> Indicates an explosion hazard. This symbol indicates this risk <i>could or might</i> cause physical injury.
	<b>FLAMMABLE GAS HAZARD.</b> Alerts you to gases that are compressed, liquefied or dissolved under pressure and can ignite on contact with an ignition source. This symbol indicates this risk <i>could or might</i> cause physical injury.
	<b>GLOVES REQUIRED:</b> Indicates that you must wear gloves when performing a task or physical injury <i>could or might</i> occur.
	<b>HAND AND CHEMICAL HAZARD:</b> Indicates that chemical damage or physical injury <i>could or might</i> occur.
	<b>CRUSH HAZARD:</b> Indicates that a hand or fingers damage <i>could or might</i> occur.
	<b>HARMFUL.</b> Indicates that the presence of harmful material <i>will, could, or might</i> occur.
	<b>INSTRUMENT DAMAGE:</b> Indicates that damage to the instrument or component <i>might</i> occur. This damage might not be covered under the standard warranty.
	<b>LIFTING HAZARD.</b> Indicates that a physical injury <i>could or might</i> occur if two or more people do not lift an object.
	<b>MATERIAL AND EYE HAZARD:</b> Indicates that eye damage <i>could or might</i> occur.
	<b>READ MANUAL:</b> Alerts you to carefully read your instrument's documentation to ensure your safety and the instrument's operational ability. Failing to carefully read the documentation <i>could or might</i> put you at risk for a physical injury.
	<b>TOXIC SUBSTANCES HAZARD:</b> Indicates that exposure to a toxic substance could occur and that exposure <i>could or might</i> cause personal injury or death.



**LASER HAZARD.** Indicates that exposure to a laser beam *will, could, or might* cause personal injury.













For the prevention of personal injury, this general warning symbol precedes the **WARNING** safety alert word and meets the ISO 3864-2 standard. In the vocabulary of ANSI Z535 signs, this symbol indicates a possible personal injury hazard exists if the instrument is improperly used or if unsafe actions occur. This symbol and another appropriate safety symbol alerts you to an imminent or potential hazard that *could cause personal injury*.

## Instrument Markings and Symbols





Table 1 explains the symbols used on Thermo Fisher Scientific instruments. Only a few of them are used on the TriPlus RSH. See the asterisk.

**Table 1.** Instrument Marking and Symbols (Sheet 1 of 2)

Symbol	Description
— — —	Direct Current
*	 Alternating Current
	Both direct and alternating current
3 	Three-phase alternating current
	Earth (ground) terminal
	Protective conductor terminal
	Frame or chassis terminal
	Equipotentiality
*	On (Supply)
*	○ Off (Supply)
	Equipment protected throughout by DOUBLE INSULATION or REINFORCED INSULATION (Equivalent to Class II of IEC 536)
	Fuse
*	 Instruction manual symbol affixed to product. Indicates that the you must refer to the manual for specific <b>WARNING</b> or <b>CAUTION</b> information to avoid personal injury or damage to the product.



**Table 1.** Instrument Marking and Symbols (Sheet 2 of 2)

Symbol	Description
	Caution, risk of electric shock
* 	Caution, hot surface
* 	Caution, biohazard
* 	Caution, Laser beam
* 	Symbol in compliance to the Directive 2002/96/EC on Waste Electrical and Electronic Equipment (WEEE) placed on the european market after August, 13, 2005.

## Safety Information and Warnings

This safety guide raises awareness of potential safety issues and general points for consideration for Thermo Fisher Scientific representatives during installation, and repair of the TriPlus RSH, or parts of it (following the life cycle principle), as well as for the end user TriPlus RSH in the lab during the learning phase, and in routine work.



**IMPORTANT** Read this section first before operating the TriPlus RSH.

## General Considerations

- Before a unit is put to use, consult the TriPlus RSH User Guide and related documents under all circumstances.
- Changes or modifications to this unit not expressly approved by the party responsible for compliance, could void your's authority to operate the equipment.
- Be aware that if the equipment is used in a manner not specified by the manufacturer, the protective and safety features of the equipment might be impaired.
- The repair of instrument failures caused by operation in a manner not specified by the manufacturer is expressly excluded from the standard warranty and service contract coverage.
- When for technical reasons it is necessary to work on instrument parts which might involve a potential hazard (moving parts, components under voltage, and so on.) contact the Thermo Fisher Scientific authorized representative.

In general, this type of situation arises when access to the parts is only possible using a tool. When you perform a maintenance operation, you must have received proper training to carry out that specific task.

## Electrical Hazards



Every analytical instrument has specific hazards. Be sure to read and comply with the following pre-cautions. They ensure the safe and long-term use of your TriPlus RSH.

The installation over-voltage category is Level II. The Level II category pertains to equipment receiving its electrical power from the local level, such as an electrical wall outlet.

Connect the TriPlus RSH only to instruments complying with IEC 61010 safety regulations.

The power line and the connections between the TriPlus RSH and other instruments, used in the configuration setup of the total analytical system, must maintain good electrical grounding. Poor grounding represents a danger for the operator, and might seriously affect the performance of the instrument.

Do not connect the TriPlus RSH to power lines that supply devices of a heavy duty nature, such as motors, refrigerators and other devices that can generate electrical disturbances.



Use only fuses of the type and current rating specified. Do not use repaired fuses, and do not short-circuit the fuse holder. The supplied power cord must be inserted into a power outlet with a protective earth (ground) contact. When using an extension cord, make sure that the cord also has an earth contact.

If the supplied power cord does not fit the local electrical socket and a replacement or adapter has to be purchased locally, make sure that only a certified power cord is used. Any power cord used must be certified by the appropriate local authorities.

Pay attention not to leave any cable connecting the TriPlus RSH and the chromatographic system, or the power cord close to heated zone, such as the injector or detector heating blocks, or the GC hot air vents.

Always replace any cable showing signs of damage with another one provided by the manufacturer. Safety regulations must be respected.



Do not change the external or internal grounding connections. Tampering with or disconnecting these connections could endanger you and damage the TriPlus RSH. The instrument is properly grounded in accordance with these regulations when shipped. To ensure safe operation, you do not must make any changes to the electrical connections or the instrument's chassis.



Do not turn the instrument on if you suspect that it has incurred any type of electrical damage. Instead, disconnect the power cord and contact a Thermo Fisher Scientific representative for a product evaluation. Do not attempt to use the instrument until it has been evaluated. Electrical damage might have occurred if the TriPlus RSH shows visible signs of damage, exposure to any liquids or has been transported under severe stress.



Damage can also result if the instrument is stored for prolonged periods under unfavorable conditions: for example, subjected to heat, moisture, and so on. Ensure that the power supply/controller unit is always placed in a clean and dry position. Avoid any liquid spills in the vicinity.



Before attempting any type of maintenance work, always disconnect the power cords from the power supply(ies) if optional devices are installed. Capacitors inside the instrument might still be charged also if the instrument is turned off.

To avoid damaging electrical parts, do not disconnect an electrical assembly while power is applied to the TriPlus RSH. After the power is turned off, wait approximately 30 seconds before you disconnect an assembly.



The instrument includes a number of integrated circuits. These circuits might be damaged if exposed to excessive line voltage fluctuations, power surges or electrostatic charges, or both.



Never try to repair or replace any components of the instrument without the assistance of a Thermo Fisher Scientific representative. There are no operator-serviceable or replaceable parts inside the power supply(ies) or in the TriPlus RSH. If a power supply is not functioning, contact a Thermo Fisher Scientific representative.



The power supplies for the TriPlus RSH, the Temperature Controlled Drawer have the symbols **I/O** on the label for the power switch to indicate ON/OFF. If a Temperature Controlled Drawer is installed in combination with a TriPlus RSH, a second power supply is active in the complete system. Turning OFF the two power supplies, or pulling the two power cords in an emergency, stop the entire TriPlus RSH.

It is important that the power supply(ies) is in a location where the power ON/OFF switch is accessible and easy to operate, and where it is possible to unplug the AC power cord from the power supply/wall outlet in case of emergency.

## Laser Safety Information



Safety Warning for Laser Class 1 Product.

**CLASS 1 LASER PRODUCT**  
**LASER KLASSE 1**  
**APPAREIL À LASER DE CLASSE 1**

**WARNING** The installed Laser device is a Class 1 Laser Product.

Class 1 Laser devices are not considered to be hazardous when used for their intended purpose. The following statement is required to comply with US and international regulations:

**CAUTION** Use of controls, adjustments or performance of procedures other than those specified herein might result in hazardous laser light exposures.

- The selected Class 1 Laser for the TriPlus RSH module Barcode Reader complies with the following regulations:

## Preface

### Safety Information and Warnings

- 21 CFR1040.10 and 1040.11 except for deviations pursuant to Laser Notice No. 50, dated July 26, 2001
- EN60825-1:1994 + A1:2002 + A2:2001
- IEC60825-1:1993 + A1:1997 + A2:2001

The software contains a built-in safety time limit such that the laser scanning mechanism cannot be operated in AIM mode for more than 5 continuous seconds.

## Other Hazards



To avoid injury and possible infection through contamination during TriPlus RSH operation, keep your hands away from the syringe.



Do not operate the TriPlus RSH without the safety guard. The safety guard must be installed for safe operation. Do not place any objects inside the area of the safety guard. Keep away from the area around the safety guard during operation of the TriPlus RSH.



Danger of crushing to fingers and hands. To avoid injury keep your hands away from moving parts during operation. Turn off the power to the TriPlus RSH if you must reach inside a mechanically powered system with moving parts.



To avoid injury, observe safe laboratory practice when handling solvents, changing tubing, or operating the TriPlus RSH. Know the physical and chemical properties of the solvents you use. See the MSDS (Material Safety Data Sheets) from the manufacturer of the solvents being used.

When using the TriPlus RSH, follow the generally accepted procedures for quality control and method development.

When using the TriPlus RSH, follow the generally accepted procedures for quality control and method development.

When using the TriPlus RSH in the field of chromatographic analysis, if a change is observed in the retention of a particular compound, in the resolution between two compounds, or in the peak shape, immediately determine the reasons for the changes. Do not rely on the separation results until you determine the cause of a change.

Do not operate on the instrument components that form part of the work area of the TriPlus RSH when it is in motion.



Use caution when working with any polymer tubing under pressure:

- Always wear eye protection when near pressurized polymer tubing.
- Do not use polymer tubing that has been severely stressed or kinked.

- Do not use polymer tubing, in particular no PEEK or Tefzel tubing when using tetrahydrofuran (THF), dimethylsulfoxide (DMSO), chlorinated organic solvents, concentrated mineral acids such as nitric, phosphoric or sulfuric acids, or any related compounds.



Do not use vials without a sealing cap, or microtiter or deepwell plates without a plate seal. Vapor phase from organic solvents can be hazardous and flammable. Acidic vapor phase can cause corrosion to critical mechanical parts.



When sample vials have to undergo heating and agitation, it is important to consider the glass quality. Use high quality glass only. Remember that depending on the application conditions, high pressure can build up in the vial. Whenever a temperature greater than 60 °C is applied, consider the vapor pressure of the solvent used to ensure that no excessive pressure builds up. This is important when using a temperature above 100°C and especially at the maximum temperature of 200 °C. Be aware that solid materials can also contain volatile compounds such as water (humidity) which could cause build-up of excess vapor pressure.

Do not reuse headspace vials. During the process of washing the vial, micro-cracks can form which will weaken the glass wall and increase the chances of the vial breaking.



In case of a single fault situation where the temperature control of the Agitator fails, there is the potential danger that the device will heat up in an uncontrolled manner until it reaches the cut-off temperature of the over temperature fuse, in this case, 240 °C. Based on this single fault scenario, when working with flammable solvents, ensure that the solvent used has a flash point which is 25 °C higher than the maximum potential temperature (240 °C) of the Agitator.

## Working with Toxic or other Harmful Compounds



**WARNING** Before using hazardous substances (toxic, harmful, and so on), please read the hazard indications and information reported in the applicable Material Safety Data Sheet (MSDS). Use personal protective equipment according to the safety requirements.

Before using dangerous substances (toxic, harmful, and so on) read the hazard indications and information reported in the Material Safety Data Sheet (MSDS) supplied by the manufacturer, referring to the relevant CAS (Chemical Abstract Service) number. The TriPlus RSH requires the use of several chemical products with different hazard characteristics, which are present in vials and syringes. Before using these substances or replacing the syringe, please read the hazard indications and information reported in the MSDS supplied by the manufacturer referring to the relevant CAS number.

When preparing the samples, please refer to local regulations for the ventilation conditions of the work room.

All waste materials must be collected and eliminated in compliance with the local regulations and directives in the country where the instrument is used.

## Biological Hazards



In laboratories where samples with potential biological hazards are handled, you must label any equipment or parts thereof which might become contaminated with biohazardous material. The appropriate warning labels are included with the shipment of the instrument. It is your responsibility to label the relevant parts of the instrument.

When working with biohazardous materials, it is your responsibility to fulfill the following mandatory requirements:

- Instructions on how to safely handle biohazardous material must be provided.
- Operators must be trained and made aware of the potential dangers.
- Personal protective equipment must be provided.
- Instructions must be provided on what to do in case operators are exposed to aerosols or vapors during normal operation (within the intended use of the equipment) or in case of single fault situations such as a broken vial.  
The protective measures must consider potential contact with the skin, mouth, nose (respiratory organs), and eyes.
- Instructions for decontamination and safe disposal of the relevant parts must be provided.

It is your responsibility to handle hazardous chemicals or biological compounds (including, but not limited to, bacterial or viral samples and the associated waste), safely and in accordance with international and local regulations.

## Maintenance

Any external cleaning or maintenance must be performed with the TriPlus RSH turned off and the power cord disconnected. Avoid using solvents and spraying on electrical parts. For the removal of potentially dangerous substances (toxic, harmful, and so on) read the hazard indications and information reported in the MSDS (Material Safety Data Sheet) supplied by the manufacturer referring to the relevant CAS (Chemical Abstract Service) number. Use proper protective gloves.

When working with hazardous materials such as radioactive, biologically hazardous material, and so on, it is important to train all operators how to respond in case of spills or contamination.

Depending on the class of hazardous material, the appropriate measures have to be taken immediately. Therefore, the chemicals or solvents needed for decontamination have to be on hand.

Any parts of the equipment which can potentially be contaminated, such as the sample vial rack, syringe tool, wash module, and so on, must be cleaned regularly. The waste solvent from cleaning and any hardware which requires to be disposed of has to be properly eliminated with all the necessary precautions, abiding by national and international regulations.

When preparing for decontamination, ensure that the solvent or chemical to be used will not damage or react with the surface, dye (color) of the instrument, table or other nearby objects. If in doubt, please contact your Thermo Fisher Scientific representative to verify the compatibility of the type or composition of solvents with the TriPlus RSH.

## Disposal



Do not dispose of this equipment or parts thereof unsorted in municipal waste. Follow local municipal waste regulations for proper disposal provisions to reduce the environmental impact of waste electrical and electronic equipment (WEEE).

European Union customers: Call your local customer service representative responsible for the TriPlus RSH for complimentary equipment pick-up and recycling.

**WARNING** The customer has to ensure that the TriPlus RSH has not been contaminated by any hazardous chemical or biological compounds including (but not limited to) bacteria or viruses.

Any part which had direct contact with the analytical sample must be identified and must undergo an appropriate decontamination procedure prior to shipping for disposal.

Potentially dangerous components are: Syringes, Vials and Well Plates. Any critical parts sent for disposal must be handled according to national laws for hazardous compounds.

The customer and the service engineer are fully responsible for enforcing these requirements. Thermo Fisher Scientific will hold the representative, customer responsible, or both, if these regulations are not observed.





# TriPlus RSH Site Preparation

This chapter gives you the information you need to prepare your site for the installation of the TriPlus RSH.

## Contents

- [Writing Conventions for TriPlus RSH](#)
- [Entrance Requirements](#)
- [Space and Load Requirements](#)
- [Power Requirements](#)
- [Environment Requirements](#)
- [Gas Equipment Requirements](#)
- [Receiving Instruments](#)
- [What Happens Next?](#)



**CAUTION** This guide does not include the information to prepare your lab for the installation of your gas chromatographic system. You can find all the instruction in the *Preinstallation Requirements Guide* of your GC system.

TriPlus RSH operates reliably under controlled environment conditions. Operating or maintaining a system outside the specifications outlined in this guide might cause many different types of system failures. The repair of such failures is specifically excluded from the standard warranty and service contract coverage.

**Note** In addition to the information in this guide, you must also obey the building and safety rules and regulations for construction that apply in your area.

## Writing Conventions for TriPlus RSH

As **X-axis** (Width) the longitudinal crossrail is intended.

As **Y-axis** (Depth) the orthogonal crossrail is intended.

As **Z-axis** (Height) the TriPlus RSH head is intended.

**Figure 1.** TriPlus RSH Axes and Support Legs

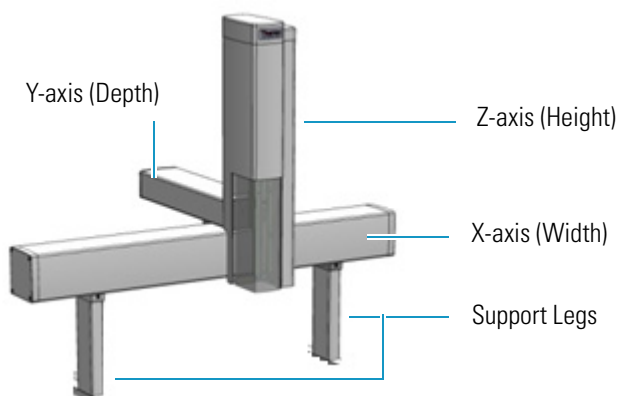

## Entrance Requirements

Use the following guidelines to make sure the entrance to your site will allow delivery of the TriPlus RSH.

1. Ensure the width of your delivery door opening is at least 80 cm (32 in.).
2. Make sure you have enough room to move boxes around corners, into elevators, or through doorways. The table below contains the dimensions and weight of shipping boxes, so that you can make accommodations:

**Table 1.** Container Dimensions

Container	Depth	Width	Height	Mass
TriPlus RSH with standard X-axis	65 cm (26 in.)	100 cm (39 in.)	32 cm (13 in.)	45-55 kg (99-122 lbs)
Pallet for TriPlus RSH standard	70 cm (28 in.)	105 cm (41 in.)	13 cm (5 in.)	
TriPlus RSH with extended X-axis	65 cm (26 in.)	136 cm (54 in.)	32 cm (13 in.)	55-60 kg (122-132 lbs)
Pallet for TriPlus RSH extended	70 cm (28 in.)	140 cm (55 in.)	13 cm (5 in.)	

## Space and Load Requirements

TriPlus RSH has to be installed on the top of the GC. Use the following tables to verify and determine the space and mass requirements for the instrument of your GC system.



**IMPORTANT** The measure reported in the tables are rounding-up for excess. The tables do not include optional instruments e.g. computers, printers, etc. The GC system should be placed on a workbench that has minimum dimensions of 0.75×2 m (2.5×6 ft.).

**Table 2.** Space and Load Requirements

Instrument	Depth (Y-axis)		Width (X-axis)		Height (Z-axis)		Mass	
	cm	in.	cm	in.	cm	in.	kg	lbs
TriPlus RSH standard X axis	46 <sup>1</sup>	18 <sup>1</sup>	85	33.5	54	21.3	13.3 <sup>4</sup>	29.3 <sup>4</sup>
TriPlus RSH extended X-axis	46 <sup>1</sup>	18 <sup>1</sup>	120.5	47	54	21.3	15.3 <sup>4</sup>	33.7 <sup>4</sup>
TriPlus RSH standard X axis (Working Range)	80 <sup>1</sup>	31.5	99 <sup>2</sup>	39 <sup>2</sup>	53 (74) <sup>3</sup>	20.9 (29) <sup>3</sup>	25	55
TriPlus RSH extended X-axis (Working Range)	80 <sup>1</sup>	31.5	135 <sup>2</sup>	53 <sup>2</sup>	53 (74) <sup>3</sup>	20.9 (29) <sup>3</sup>	27	60
TRACE 1300	60	24	44	17	45	18	55	121
TRACE 1310	67	26	44	17	45	18	55	121
TRACE GC Ultra	69	27	61	24	51	20	48	105
FOCUS GC	56	22	36	14	48	19	30	66
TSQ 8000 MS	89	35	40	16	45	18	61	135
ISQ MS	69	27	36	14	46	18	45	99
DSQ II MS	68	27	38	15	44	17	45	98
ITQ MS	68	27	38	15	44	17	45	98
TSQ MS	69	27	56	22	76	30	118	258
Computer <sup>5, 6</sup>	48	19	20	8	43	17	12	27
Monitor <sup>6</sup>	16	7	46	18	32	13	4	8
Keyboard <sup>6</sup>	23	9	46	18	50	2	1	2

<sup>1</sup> About 20 cm (about 8-in.) of the orthogonal crossrail (Y-axis) are protruding the rear of the GC.

<sup>2</sup> Dimension of the entire working range including Handheld bracket

<sup>3</sup> Dimension including the support legs [about 22 cm (8.7 in.) height]

<sup>4</sup> Mass without accessories.

<sup>5</sup> This item is placed on the floor under the system, thereby reducing the weight requirements for your workbench.

<sup>6</sup> Dimensions vary per manufacturer, therefore approximations are provided.

3. Allow at least 30 cm (12 in.) of clearance behind the GC. Before switching on TriPlus, move the crossrails to verify the absence of obstacles.
4. Make sure you have at least 92 cm (3 ft.) of clearance above the system.
5. Make sure your workbench can support a TriPlus RSH system. Keep in mind, additional instruments add to the total weight.
6. Ensure that your work area is stable and free of vibration from nearby equipment. The system is a sensitive instrument.

## GC System + TriPlus RSH Configuration

The main GC System + TriPlus RSH configurations are reported in [Table 3](#):

**Table 3.** GC System + TriPlus RSH Configurations (Sheet 2 of 2)

Configuration
TRACE 1300/1310 + TriPlus RSH (Use TriPlus RSH with standard or extended X-axis)
TRACE GC Ultra + TriPlus RSH (Use TriPlus RSH with standard or extended X-axis)
TRACE GC Ultra + TRACE GC Ultra + TriPlus RSH (Use TriPlus RSH with standard or extended X-axis)
FOCUS GC + TriPlus RSH (Use TriPlus RSH with standard or extended X-axis)
FOCUS GC + FOCUS GC + TriPlus RSH (Use TriPlus RSH with standard or extended X-axis)
FOCUS GC + TRACE GC Ultra+ TriPlus RSH (Use TriPlus RSH with standard or extended X-axis)
TSQ 8000 MS + TRACE 1300/1310 + TriPlus RSH
ISQ MS + TRACE 1300/1310 + TriPlus RSH
DSQ II MS + TRACE 1300/1310 + TriPlus RSH
ITQ MS + TRACE 1300/1310 + TriPlus RSH
TSQ MS + TRACE 1300/1310 + TriPlus RSH (Use TriPlus RSH with standard or extended X-axis)

**Table 3.** GC System + TriPlus RSH Configurations (Sheet 2 of 2)

**Configuration**

TSQ 8000 MS + TRACE GC Ultra + TriPlus RSH

ISQ MS + TRACE GC Ultra + TriPlus RSH

DSQ II MS + TRACE GC Ultra+ TriPlus RSH

ITQ MS + TRACE GC Ultra + TriPlus RSH

TSQ MS + TRACE GC Ultra + TriPlus RSH

(Use TriPlus RSH with standard or extended X-axis)

TSQ 8000 MS + FOCUS GC + TriPlus RSH

ISQ MS + FOCUS GC + TriPlus RSH

DSQ II MS + FOCUS GC + TriPlus RSH

ITQ MS + FOCUS GC + TriPlus RSH

(Use TriPlus RSH with standard or extended X-axis)

TRACE GC Ultra + TSQ 8000 MS + TRACE GC Ultra+ TriPlus RSH

TRACE GC Ultra + ISQ MS + TRACE GC Ultra+ TriPlus RSH

TRACE GC Ultra + DSQ II MS + TRACE GC Ultra+ TriPlus RSH

TRACE GC Ultra + ITQ MS + TRACE GC Ultra+ TriPlus RSH

TRACE GC Ultra + TRACE GC Ultra +TSQ MS + TriPlus RSH

(Only use TriPlus RSH with extended X-axis)

FOCUS GC + TSQ 8000 MS + TRACE GC Ultra + TriPlus RSH

FOCUS GC + ISQ MS + TRACE GC Ultra + TriPlus RSH

FOCUS GC + DSQ II MS + TRACE GC Ultra + TriPlus RSH

FOCUS GC + ITQ MS + TRACE GC Ultra + TriPlus RSH

FOCUS GC + TRACE GC Ultra + TSQ MS + TriPlus RSH

(Only use TriPlus RSH with extended X-axis)

## GC System + TriPlus RSH Configuration Space and Mass Requirements

TriPlus RSH has to be installed on the top of the GC. Use the following tables to determine the space and mass requirements according to your GC system + TriPlus RSH configuration.

**IMPORTANT** The dimensions reported in the tables are rounding-up for excess.

The dimensions are calculated considering the distances that must be leaved between the units of the GC system:

- About **9 cm** between a TRACE GC Ultra and a second TRACE GC Ultra.
- About **6 cm** between a FOCUS and a TRACE GC Ultra.
- About **13 cm** between a FOCUS and another FOCUS GC.
- **1 cm** between a GC and a TSQ 8000 mass spectrometer
- **1 cm** between a GC and a ISQ mass spectrometer
- **5 cm** between a GC and a ITQ mass spectrometer
- **5 cm** between a GC and a DSQ II mass spectrometer
- **10 cm** between a GC and a TSQ mass spectrometer

**Table 4.** Overall Dimensions of the GC System + TriPlus RSH with Standard X-axis Configuration (Sheet 1 of 2)

Configuration	Depth		Width		Height		Mass	
	cm	in.	cm	in.	cm	in.	kg	lbs
TRACE 1300/1310 + TriPlus RSH	80	31.5	99	39	119	47	80	176
TSQ 8000 MS + TRACE 1300/1310 + TriPlus RSH	89	35	99	39	119	47	129	285
ISQ MS + TRACE 1300/1310 + TriPlus RSH	80	31.5	130	51	119	47	125	276
DSQ II MS + TRACE 1300/1310 + TriPlus RSH	80	31.5	132	52	119	47	125	276
ITQ MS + TRACE 1300/1310 + TriPlus RSH	80	31.5	132	52	119	47	125	276
TRACE 1300/1310 + TSQ MS + TriPlus RSH	80	31.5	158	62	119	47	198	437
TRACE GC + TriPlus RSH	89	35	99	39	127	50	73	160
TRACE GC + TRACE GC Ultra+ TriPlus RSH	89	35	131	52	127	50	121	272
FOCUS GC + TriPlus RSH	76	30	99	39	127	50	55	121
FOCUS GC + FOCUS GC + TriPlus RSH	76	30	99	39	127	50	85	187
FOCUS GC + TRACE GC Ultra + TriPlus RSH	89	35	103	40.5	127	50	103	227
TSQ 8000 MS + TRACE GC Ultra + TriPlus RSH	89	35	103	40.5	127	50	134	295
ISQ MS + TRACE GC Ultra + TriPlus RSH	89	35	104	40.9	127	50	118	260
DSQ II MS + TRACE GC Ultra + TriPlus RSH	89	35	104	40.9	127	50	118	260
ITQ MS + TRACE GC Ultra + TriPlus RSH	89	35	104	40.9	127	50	118	260
TRACE GC Ultra + TSQ MS + TriPlus RSH	89	35	190	74.8	127	50	191	421
TSQ 8000 MS + FOCUS GC + TriPlus RSH	89	35	99	39	127	50	116	256
ISQ MS + FOCUS GC + TriPlus RSH	89	35	73	28.7	127	50	100	220

**Table 4.** Overall Dimensions of the GC System + TriPlus RSH with Standard X-axis Configuration (Sheet 2 of 2)

Configuration	Depth		Width		Height		Mass	
	cm	in.	cm	in.	cm	in.	kg	lbs
DSQ II MS + FOCUS GC + TriPlus RSH	89	35	77	30.3	127	50	100	220
ITQ MS + FOCUS GC + TriPlus RSH	89	35	77	30.3	127	50	100	220

**Table 5.** Overall Dimensions of the GC System + TriPlus RSH with Extended X-axis Configuration (Sheet 1 of 2)

Configuration	Depth		Width		Height		Mass	
	cm	in.	cm	in.	cm	in.	kg	lbs
TRACE 1300/1310 + TriPlus RSH	80	31.5	135	53	119	47	82	180
TSQ 8000 MS + TRACE 1300/1310 + TriPlus RSH	89	35	135	53	119	47	143	315
ISQ MS + TRACE 1300/1310 + TriPlus RSH	80	31.5	135	53	119	47	127	280
DSQ II MS + TRACE 1300/1310 + TriPlus RSH	80	31.5	135	53	119	47	127	280
ITQ MS + TRACE 1300/1310 + TriPlus RSH	80	31.5	135	53	119	47	127	280
TRACE 1300/1310 + TSQ MS + TriPlus RSH	80	31.5	191	75	119	47	200	441
TRACE GC Ultra + TriPlus RSH	89	35	135	53	127	50	75	165
TRACE GC Ultra + TRACE GC Ultra + TriPlus RSH	89	35	135	53	127	50	123	272
FOCUS GC + TriPlus RSH	76	30	135	53	127	50	57	126
FOCUS GC + FOCUS GC + TriPlus RSH	76	0	135	53	127	50	87	192
FOCUS GC + TRACE GC Ultra + TriPlus RSH	89	35	135	53	127	50	105	232
TSQ 8000 MS + TRACE GC Ultra + TriPlus RSH	89	35	135	53	127	50	136	300
ISQ MS + TRACE GC Ultra + TriPlus RSH	89	35	135	53	127	50	120	265
DSQ II MS + TRACE GC Ultra + TriPlus RSH	89	35	135	53	127	50	120	265
ITQ MS + TRACE GC Ultra + TriPlus RSH	89	35	135	53	127	50	120	265
TRACE GC Ultra + TSQ MS + TriPlus RSH	89	35	135	53	127	50	193	426
TSQ 8000 MS + FOCUS GC + TriPlus RSH	89	35	135	53	127	50	118	260
ISQ MS + FOCUS GC + TriPlus RSH	89	35	135	53	127	50	102	225
DSQ II MS + FOCUS GC + TriPlus RSH	89	35	135	53	127	50	102	225
ITQ MS + FOCUS GC + TriPlus RSH	89	35	135	53	127	50	102	225
TRACE GC Ultra + TSQ 8000 MS + TRACE GC Ultra + TriPlus RSH	89	35	164	65	127	50	184	406
FOCUS GC + TSQ 8000 MS + TRACE GC Ultra + TriPlus RSH	89	35	139	55	127	50	166	366
FOCUS GC + TSQ 8000 MS + FOCUS + TriPlus RSH	89	35	135	53	127	50	148	326
TRACE GC Ultra + ISQ MS + TRACE GC Ultra + TriPlus RSH	89	35	160	63	127	50	168	371
FOCUS GC + ISQ MS + TRACE GC Ultra + TriPlus RSH	89	35	135	53	127	50	150	331

**Table 5.** Overall Dimensions of the GC System + TriPlus RSH with Extended X-axis Configuration (Sheet 2 of 2)

Configuration	Depth		Width		Height		Mass	
	cm	in.	cm	in.	cm	in.	kg	lbs
FOCUS GC + ISQ MS + FOCUS + TriPlus RSH	89	35	135	53	127	50	132	292
TRACE GC Ultra + DSQ II MS + TRACE GC Ultra + TriPlus RSH	89	35	162	64	127	50	168	371
FOCUS GC + DSQ II MS + TRACE GC Ultra + TriPlus RSH	89	35	137	54	127	50	150	331
FOCUS GC + DSQ II MS + FOCUS + TriPlus RSH	89	35	135	53	127	50	132	292
TRACE GC Ultra + ITQ MS + TRACE GC Ultra + TriPlus RSH	89	35	162	64	127	50	168	371
FOCUS GC + ITQ MS + TRACE GC Ultra + TriPlus RSH	89	35	140	55	127	50	150	331
FOCUS GC + ITQ MS + FOCUS + TriPlus RSH	89	35	135	53	127	50	150	331
TRACE GC Ultra + TRACE GC Ultra + TSQ MS + TriPlus RSH	89	35	210	82.6	127	50	241	532
FOCUS GC + TRACE GC Ultra + TSQ MS + TriPlus RSH	89	35	170	67	127	50	223	492
FOCUS GC + FOCUS + TSQ MS + TriPlus RSH	89	35	210	82.6	127	50	205	452

## Power Requirements

This paragraph gives details on the power requirements.

### Power Line

**CAUTION** The power line and the connections between the instruments must maintain good electrical grounding. Poor grounding represents a danger for the operator and might seriously affect the instrument performance.

Do not connect the TriPlus RSH to lines feeding devices of a heavy-duty nature, such as motors, UV lamps, refrigerators, air compressors and other devices that can generate disturbances.



Pay attention not to leave any cable connecting the sampling unit and the chromatographic system or the power cord close to the GC hot air vents.

Occasionally, unacceptable quality in line power sources might adversely affect the operation of a GC system. It is the user's responsibility to correct line voltage problems. Specifying power conditioning equipment is a complex task that is best handled by a company or consultant specializing in that field. Contact your Thermo Fisher Scientific Field Service Engineer (FSE) for assistance in locating a power consultant.

### Power Module

The TriPlus RSH must be electrically supplied by using a dedicated power supply module. A second Power module is required in case a Stack modules (Peltier) is installed. Do not use the same Power module as used for the TriPlus robot.



**CAUTION** The Power Module should be placed on a sturdy, level bench with adequate access to the main power switch.

## Electrical Specifications

The electrical specifications and the various protection classes are provided below.

**Table 6.** Electrical Specifications (Sheet 1 of 2)

Parameter	Requirements
Protection Class	Class I
Over voltage category	Category II
Pollution degree	2
Moisture protection	Normal (IPX0)
Voltage	36 VDC
Current	3.2 A
Fuse	T6.3 A/250 V

Power Supply; Handheld Controller	Requirements
Input line voltage	Grounded AC, 100 to 240 V
Input line frequency	50/60 Hz
Input power	5 A
Output Voltage	36 VDC
Output current	5.55 A (total for two Outlets)

Use the following guidelines to ensure your site is equipped with enough power to support the system.

**Table 7.** System Power Requirements (Sheet 1 of 2)

Equipment	Maximum Power (W)
TriPlus RSH	200 W with a single power module 400 W with two power modules
TRACE GC Ultra	1920
FOCUS GC	1600
TSQ 8000 MS , including foreline pump	1080
ISQ MS, including foreline pump	1200
DSQ II MS	700

**Table 7.** System Power Requirements (Sheet 2 of 2)

Equipment	Maximum Power (W)
ITQ MS	700
TSQ-Quantum XLS MS	2310
Computer *	400
Monitor *	25

\* Power requirements vary by manufacturer.

## Environment Requirements

The operating environment in your laboratory is affected by such factors as temperature, humidity, particulate matter, and electrostatic discharge.

It is your responsibility to provide an acceptable operating environment for your TriPlus RSH. Attention to the operating environment will ensure continued high performance of your TriPlus RSH.

## Environmental Conditions

- Internal use
- Up to 3000 meters altitude over sea level
- Temperature 5 to 40 °C (41 to 104 °F)
- Maximum relative humidity 80%, non-condensing
- Voltage variations must not exceed the nominal voltage by  $\pm 10\%$
- Transient overloads in compliance with installation categories II
- Pollution degree according to IEC 664 (3.7.3) 2
- Protection degree IP00

Use the following guidelines to ensure your site has the proper environmental conditions for the system:

1. Ensure that your room temperature is 5-40 °C (41-104 °F). The analytical performance is only confirmed for temperatures between 15-35 °C (59-95 °F). For best performance, the operating temperature should be constant. Use the table below to calculate the amount of heat your system will generate and ensure your air-conditioning system can handle that amount of heat.

**CAUTION** Do not directly expose the GC system to any cooling duct outlets.

**Table 8.** Maximum Heat Generated by Each Instrument

Equipment	Heat Output (BTU per Hr.)	Heat Output (in W)
TriPlus RSH	683** or 1366***	200** or 400***
TRACE GC Ultra	6550	1920
FOCUS GC	5460	1600
TSQ 8000 MS, including foreline pump	3685	1080
ISQ MS, including foreline pump	4095	1200
DSQ II MS	2390	700
ITQ MS	2390	700
TSQ-Quantum XLS MS	7851	2301
Computer *	1365	400
Monitor *	85	25

\* Power requirements vary by manufacturer. \*\* Single power module \*\*\* Two power modules

2. Ensure that the relative humidity in your laboratory is between 40 and 75%, with no condensation. A temperature and humidity monitor in your laboratory helps ensure that the climate is within these specifications.

3. Ensure that the air in your site is free of excess **particulate matter**.

For reference, the air should contain fewer than 100,000 particles (larger than 5 μm) per cubic meter. If the concentration is larger than this amount, dust can accumulate on electronic components. This accumulation reduces their ability to cool off properly and could cause them to overheat. If your environment is particularly dusty, we recommend that you purchase the optional dust filter for your system.

4. Ensure that your site is free of electrostatic discharge (ESD), which might damage the electronic components of your system. Ensure your static has been discharged before touching internal components of the instrument. ESD can damage sensitive components, resulting in premature failures.

Take the following precaution to prevent electrostatic discharge:

- Use a static-dissipating floor covering (such as tile or conductive linoleum) in the room housing your instrument.
- Use laboratory chairs covered with natural fibers or other static-dissipating material.
- Wear laboratory coats and clothing made from natural fibers or other static-dissipating material.
- Do not place polystyrene (foam) cups or packing materials on the instrument.

## Gas Equipment Requirements

An inert gas, such as helium or nitrogen is required as purge gas to for cleaning the headspace syringe or to supply the station for the fiber conditioning.

You will need a supply of ultra-high purity GC gases. It is your responsibility to ensure that two-stage safety pressure regulating device is installed the gas supply and the **Temperature Control Drawer**.

## LAN Network Requirements

The connection between the TriPlus RSH and a Thermo Scientific Chromatography Data System (Xcalibur, Chrom-Card, ChromQuest) must be carried out via Local Area Network (LAN).

Your lab must be provided with one or more RJ-45 wall outlet. To connect your system to your site's LAN network, you must have an additional shielded twisted pair network cable (cross cable).

**Note** We are not responsible for connecting to or establishing communication with your site LAN network. The FSE will test the system's ability to communicate on a mini-hub or LAN switch only (preferable).

The IP addresses assigned to the instrument must be fixed (permanently assigned) addresses. If you intend to connect your system to your site's network, each piece of equipment must have a unique, fixed (static) IP address assigned to it.

## Receiving Instruments

When you receive the TriPlus RSH system:

1. Inspect the boxes for damage when the instrument arrives. Our instruments are shipped by electronic equipment carriers who specialize in the handling of delicate equipment. Occasionally, however, equipment is inadvertently damaged in transit. If you notice evidence of external damage, do not refuse shipment. Instead, call Customer Service.
2. Once you are finished inspecting your shipment, move the cartons to a protected location, preferably the installation site. Leave the boxes as complete as possible and do not unpack or open the boxes without our Field Service Engineer (FSE) present. Doing otherwise might void your warranty or order.
3. Complete the Installation Request Form located at the front of this guide and forwards it to Customer Support.

## What Happens Next?

After the Installation Request Form is received, Customer Support will contact you to schedule the installation of your system. It is important to confirm that all the requirements on the form are met BEFORE the Field Service Engineer arrives.

The Field Service Engineer will install the system and confirm that all performance tests pass.

- a. If equipment is damaged, keep boxes and their equipment in their existing condition and immediately notify the carrier.
- b. Submit a damage claim directly to the carrier, and send a copy (including any shortage claims) to your authorized Thermo Fisher Scientific sales representative.
- c. Do not return any equipment to the dealer or the factory without prior factory authorization.

