

Figure 1 - Overall Dimensions

These instructions must be thoroughly read and understood before installing and operating this product. Failure to operate this product in accordance with the instructions could present a safety hazard to the user and will void the safety certification of this product. Modification of the unit will result in voiding the warranty. If you have any questions or concerns, please call the VWR Technical Services Department at 800-932-5000 8AM to 5PM Eastern Time (North America only). For other locations, please contact your local representative.

Please save product packaging for future use.

General Description

The VWR Ultra High Purity (UHP) Nitrogen Generators (see Figure 1) are completely engineered systems which will convert compressed air into UHP-grade nitrogen. The systems utilize a combination of purification technologies including filtration, catalytic oxidation (26000-008 only), and pressure swing adsorption. The UHP Nitrogen Generators are designed to provide high purity nitrogen gas for analytical instrumentation and other laboratory applications.

The UHP Nitrogen Generators are certified to the electrical requirements as specified by the IEC, CSA, and UL standards. These units bear both the CSA and CUL markings on the product label. Product supplied to EU carry the CE mark (220/230/240 VAC units only).

Engineered System

The VWR UHP Nitrogen Generators include all the components required to convert compressed air into ultra high purity nitrogen. The flow schematics (see Figure 2) show all of the major components of the system. The system can be broken down into four primary stages: prefiltration, hydrocarbon removal (26000-008 only), oxygen/carbon dioxide/water vapor removal, and final filtration.

Prefiltration

A Balston high efficiency coalescing filter has been incorporated into the design of the UHP Nitrogen Generator as a prefilter to remove oil, water, and particulate contamination from the incoming compressed air supply. The inlet prefilter assembly is equipped with an automatic float drain to eliminate any liquids which have accumulated within the filter housing.

In addition to the coalescing prefilter, particulate filters are incorporated into the design of the UHP Nitrogen Generator to protect internal components from particulate contamination. The Model 26000-008 has two Grade BX Balston particulate filters, and the 26000-010 has one Grade BX particulate filter as shown on the Flow Schematics (Figures 2 and 3).

Hydrocarbon Removal
 (Model 26000-008 only)

The catalyst module used for hydrocarbon removal is a stainless steel vessel filled with catalyst and assembled with a cartridge heater. This catalyst module oxidizes hydrocarbons in the compressed air supply to water vapor and carbon dioxide, which are removed in subsequent purification steps.

Oxygen Removal

The next stage in the purification process of the VWR UHP Nitrogen Generator is the removal of oxygen, water vapor, and carbon dioxide from the compressed air supply. In this stage, pressure swing adsorption (PSA) technology is utilized to reduce the concentrations of these compounds to <1 ppm (each).

Final Filtration

The final filter on the VWR UHP Nitrogen Generator is a Balston Grade GS membrane filter which removes particulate contamination to 0.01 micron (absolute).

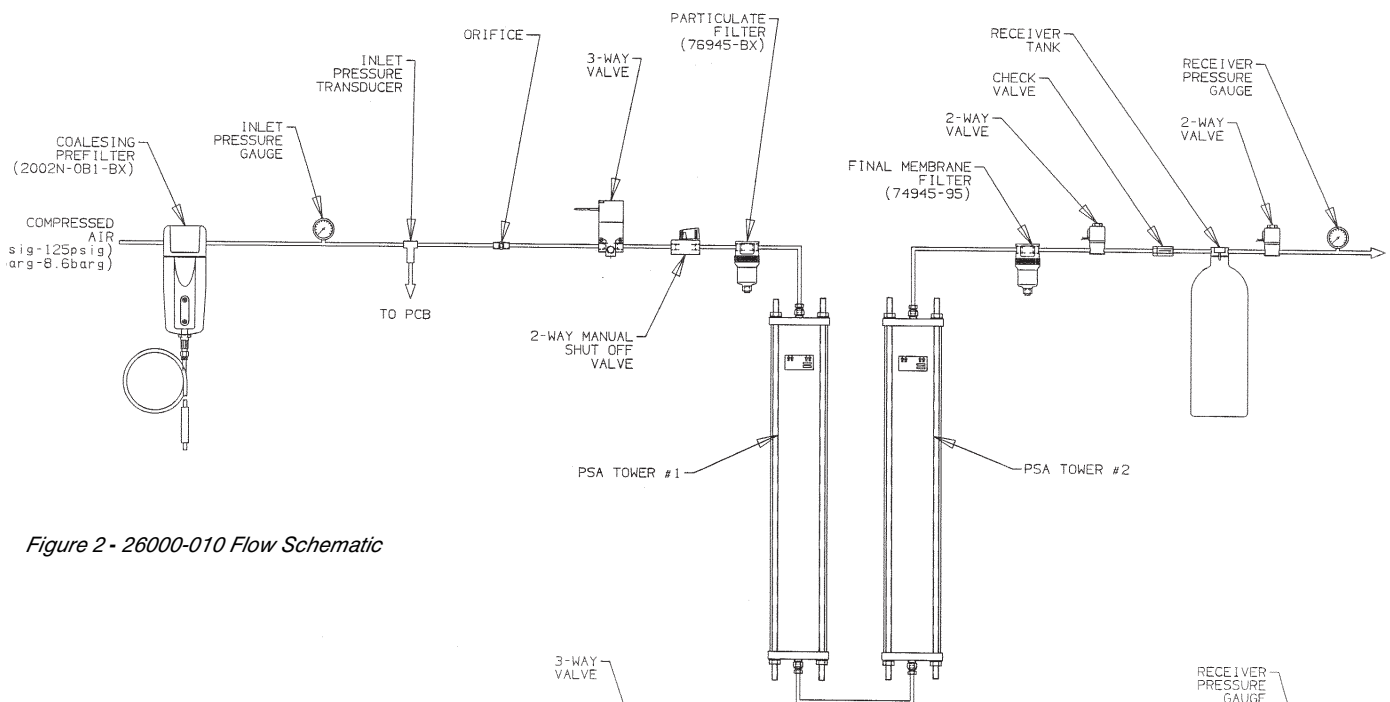

Figure 2 - 26000-010 Flow Schematic

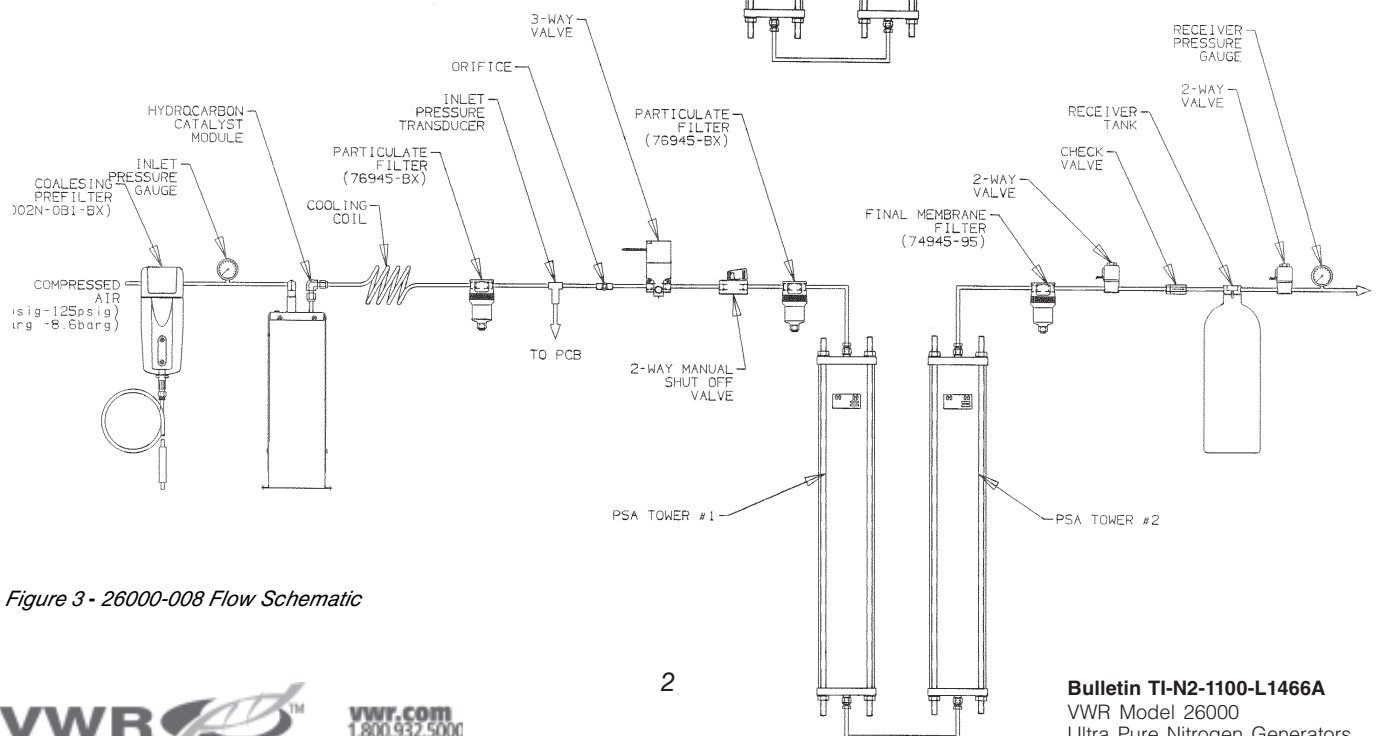

Figure 3 - 26000-008 Flow Schematic

Diagnostics

There are three diagnostic indicator lights and two diagnostic indicator gauges on the VWR UHP Nitrogen Generator.

System Check LED (yellow) - The "System Check" LED indicator has two functions: to signal system start-up mode or to signal low inlet pressure. If the yellow "System Check" LED is blinking (once per 12 seconds), the generator is in its start-up mode. If the "System Check" LED is solid, the inlet air pressure has dropped below 60 psig (4.1 barg). In the event of low inlet pressure, the generator will also emit an audible beep to alert the operator of this condition.

System Ready LED (green) - The "System Ready" LED indicator will illuminate when the generator has completed its warm-up phase and is ready to deliver UHP nitrogen to the downstream process or equipment.

Service System LED (yellow) - The "Service System" LED indicator also has two functions. If the LED is blinking, it is time to replace the hydrocarbon catalyst module as part of the routine maintenance of the generator. If the LED is solid, there may be a possible fault with the hydrocarbon catalyst module heater (Model 26000-008 only) or the electrical connections to it. **This indicator light is inoperative in the Model 26000-010 generator.**

Inlet Pressure Display - The inlet pressure gauge displays the pressure of the compressed air supply coming to the generator.

Receiver Pressure Display - The Receiver Pressure Gauge shows the pressure swing within the internal receiver tank. This diagnostic gauge allows the operator to monitor the operation of the PSA tower and to determine if there is a possible leak or overflow condition (downstream) which could adversely affect the quality of the nitrogen supply.

Installation



All installation, operation, and maintenance activities for the VWR UHP Nitrogen Generator should be performed by suitable personnel using reasonable care.

Figure 4 - Recommended Installation

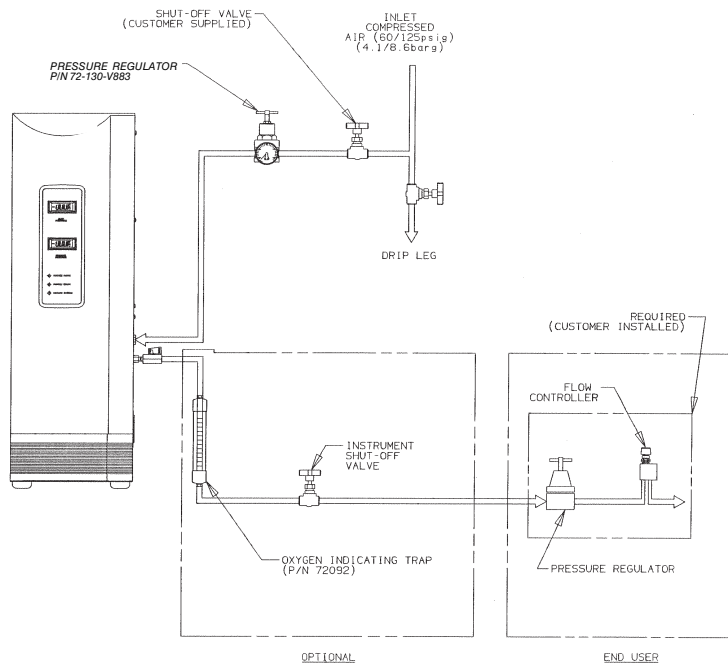

Note: Nitrogen output should pass the oxygen indicating trap during startup, until specified purity is achieved and lines are purged.

General

The VWR UHP Nitrogen Generator is a free-standing unit. **Do not suspend the Nitrogen Generator from the wall or ceiling. Its considerable weight could pose a falling hazard to personnel and equipment in its proximity. Do not install the unit outdoors.** When moving the generator, use proper equipment and lifting techniques. Do not grasp the front panel when moving the generator. Lift the generator by the metal case only.

Location

The inlet fitting for the UHP Nitrogen Generator is 1/4" female NPT, and the outlet fitting is 1/8" female NPT. A shut-off valve and pressure regulator should be installed directly upstream from the VWR UHP Nitrogen Generator (see Figure 4). The shut-off valve isolates the unit from the compressed air line for maintenance and troubleshooting activities. The pressure regulator controls the inlet air pressure and should be set to deliver compressed air to the generator between 60 psig and 125 psig (4.1 barg and 8.6 barg).

The VWR UHP Nitrogen Generator should be located in an area where the ambient temperature is between 60°F and 100°F (16°C and 38°C). Installation of the nitrogen generator in an area where the ambient temperature is not within the recommended range may adversely affect the performance and/or life of the system or void the warranty. Install the generator in a location which is protected from severe weather conditions, and is free from excessive ambient dust or dirt.

Utilities

Compressed Air - The VWR UHP Nitrogen Generator requires a source of clean, dry compressed air for optimal operation. The compressed air should be as close to instrument quality as possible and supplied at a dewpoint between 40°F and 60°F (4°C and 15°C), and at a pressure between 60 psig and 125 psig (4.1 barg and 8.6 barg). If the incoming air pressure is less than 60 psig (4.1 barg), an alarm will beep, and the system may go into a modified start-up mode (see "Pressure Interruptions" for more details). The supply air should be at room temperature and relatively free of water, compressor oil, hydrocarbons, and particulate matter. If the compressed air supply has excessive oil and water carryover from the compressor, install a prefilter upstream from the generator (see Recommended Accessories section).



Chlorinated hydrocarbon compounds and chlorofluorocarbons (or freons) will permanently contaminate the hydrocarbon catalyst module in the 26000-008 UHP Nitrogen Generator. Extreme care should be taken when specifying an air supply for the generator to ensure that these compounds are not present in the air supply nor likely to get into the compressor providing air to the generator.

The hydrocarbon catalyst module can also be contaminated by high concentrations of lead, sulfur, or phosphorous compounds, heavy metals, and long chain polymers. Care should be taken to avoid introducing these compounds into the Parker Balston 26000-008 UHP Nitrogen Generator. Specifically, assure that none of these compounds are stored near the inlet to the compressor supplying the system with compressed air. The intake for the compressor should be vented to the outdoors.

If any potentially damaging hydrocarbons, chlorofluorocarbons, chlorinated solvents or other similar components are used in close proximity to the generator or to the compressed air supply, an auxiliary hydrocarbon scrubber (P/N 76080) should be installed directly upstream from the generator.

The inlet air supply should be supplied by 1/4" or larger tubing. At least 1.5 SCFM (42 lpm) of compressed air should be available for the generator to operate properly.

Power - The VWR UHP Nitrogen Generator may be operated by a 120 VAC or 230 VAC, 50/60 Hz power supply. **Parker Hannifin recommends the use of a surge suppressor with the UHP Nitrogen Generator to protect the unit from electrical surges and spikes and to maintain the product warranty.** The generator is shipped with a tag on the power receptacle which specifies the factory setting of the voltage selector. For optimal performance of the generator, set the voltage selector to match the local power supply. **(Note:** The "NA" version of the generator is designed to run only on 120 VAC power.) To change the setting on the voltage selector, simply remove the selector/fuse drawer from the receptacle using a small screwdriver, turn the selector so the desired voltage shows in the window, and reassemble. To connect the generator to the power supply, plug the female end of the electrical cord into the receptacle on the right side of the generator, and the opposite end into a three-pronged earthed power receptacle. **Main supply line voltage must be within 10% of nominal rated voltage for the generator.**



Before plugging power cord into power receptacle, check the voltage selector setting. The voltage setting must match the local power supply voltage.

Piping Components - The inlet and outlet ports for the VWR UHP Nitrogen Generator are located on the right side of the unit (see Figure 1). The inlet port is 1/4" female NPT, and the customer supplied inlet tubing and fittings should be clean and rated for 125 psig (8.6 barg). The outlet port is 1/8" female NPT. **All tubing and fittings used downstream from the UHP Nitrogen Generator should be stainless steel or refrigeration grade copper and rated for 125 psig (8.6 barg), minimally.** Use only PTFE tape on all NPT fittings associated with the generator. (Thread sealing compounds may contaminate the process stream.)

If an indicating oxygen trap (P/N 72092) will be used with the generator, install the trap as close to the outlet port of the generator as possible. Install the trap in a vertical position to prevent channeling within the trap.

To remove trace hydrocarbon contaminants from the inside surface of the downstream (copper or stainless steel) tubing, the customer should clean the tubing prior to installation. First, connect the tubing to a supply of clean, inert gas (He or N₂). Next, initiate the gas flow through the tubing (5-10 cc/min.). Finally, heat the tubing with a propane torch, moving the flame at a rate of approximately 1/2 in./sec. in the direction of flow. This procedure will remove any trace waxes or oils used in the manufacture of the tubing.



Note: The use of plastic piping components or any piping components which are not clean will contaminate the nitrogen stream.

Drain Line - The 1/4" diameter plastic drain line attached to the compressed air prefilter is coiled underneath the generator. Pipe the drain line to an appropriate disposal container. The liquid in this drainage will consist of water and compressor oil which should be disposed of properly.

VWR strongly recommends installing a shutoff valve at the process or instrument being supplied with nitrogen from the generator unless the process or instrument has its own internal shutoff valve to isolate it from the nitrogen line.

A pressure regulator and flow controller, as detailed below, **must** be installed between the generator and the point-of-use to maintain pressure, flow, and purity specifications. If both of these control devices are incorporated into the downstream equipment being used, there is no need to install them separately. These accessories must be appropriate for high purity applications.

Pressure Regulator (downstream) - The nitrogen from the generator must be regulated to the application pressure by installing a pressure regulator, specifically designed for high purity applications, downstream from the generator.

Flow Controller - If the rated flow capacity of the generator is exceeded, the nitrogen purity will be adversely affected. Specifically, the nitrogen stream will have increased levels of oxygen, carbon dioxide and water vapor contamination. If the equipment or process used downstream from the generator does not contain a flow control device, install a metering valve (suitable for high purity applications), to set the UHP nitrogen flow rate. The flow rate (at low pressure) can be measured with a bubble-type digital flow meter.

Recommended Accessories

All accessories recommended for use **downstream** from the VWR UHP Nitrogen Generator should be appropriate for high purity applications (see Figure 4).

Prefiltration - If instrument quality compressed air is not available, or if excess water drains from the prefilter, the **Balston 2002N-1B1-DX** filter assembly should be installed, in series, on the compressed air supply line, upstream from the generator.

Pressure Regulator (upstream) - To control the incoming air pressure to between 60 psig and 125 psig (4.1 barg and 8.6 barg), use a self-relieving pressure regulator. The **Parker Balston Pressure Regulator (P/N 72-130-V883)** is a self-relieving pressure regulator with 1/2" NPT inlet and outlet ports and a pressure gauge.

Indicating Oxygen Trap - If visible verification of the purity of the nitrogen stream is desirable, install an indicating oxygen trap downstream from the UHP Nitrogen Generator. **The Indicating Oxygen Trap (P/N 72092)** is a trace oxygen scrubber which provides a visible indication of nitrogen purity downstream from the generator. The indicating trap should be installed in an easily visible location downstream from the UHP Nitrogen Generator. Install the oxygen trap in a vertical position to reduce channeling within the trap. The freshly installed indicating trap is green. As long as a portion of the trap remains green, the trap is still removing trace oxygen impurities. The trap gradually changes color from green to brown as it becomes saturated with oxygen. Replace the trap when more than half of it has been consumed (turned brown). Note: Bypass oxygen trap until nitrogen is at specified purity and lines are purged.

Hydrocarbon Scrubber - The **Parker Balston 76080 Hydrocarbon Scrubber** is designed to remove potentially damaging hydrocarbons and halogenated hydrocarbons from the compressed air supply to the VWR, 26000-008 UHP Nitrogen Generator.

Operation

The VWR UHP Nitrogen Generator requires five hours of warm-up time to achieve rated purity.

Startup

Prior to shipment from the factory, the PSA towers are pressurized with high purity nitrogen to prevent contamination from the atmosphere. The nitrogen is sealed into the towers by a 2-way valve directly upstream from the towers. Before starting the generator, remove the service panel and open this 2-way valve (see Figure 5). Replace the service panel. There is also a 2-way (external) valve at the outlet of the generator. This valve must be closed at start-up and remain closed until the 5 hour warm-up period is complete.

Open the inlet air supply valve (customer supplied) and turn the power switch (see Figure 1) on the generator upward to the ON position. The "System Check" LED indicator will start blinking once every 12 seconds. It will continue blinking during the warm-up period. The inlet air pressure should be regulated to be between 60 psig and 125 psig (4.1 barg to 8.6 barg). During the 5 hours of warm-up, there will be no flow of nitrogen from the generator.

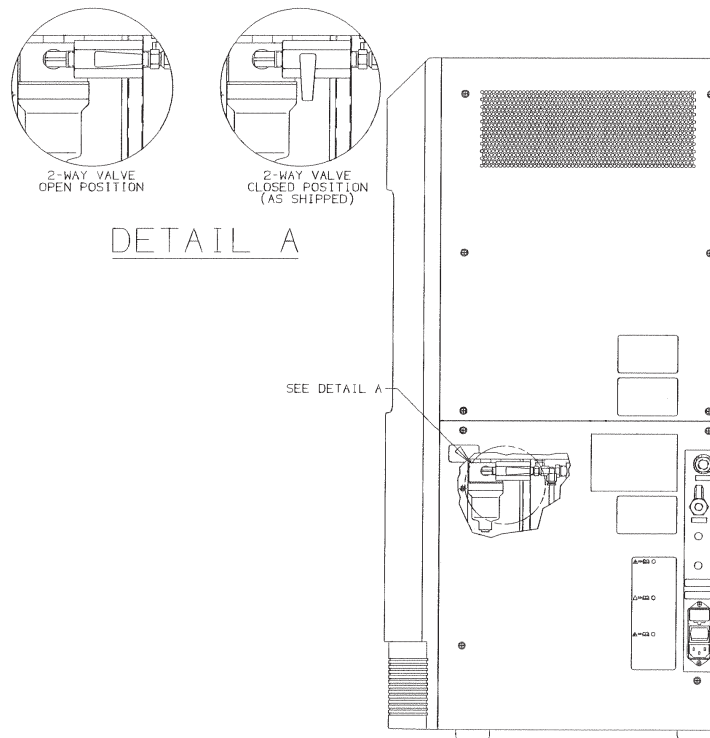

Figure 5 - Manual Shut-Off Valve

Operation

After the initial start-up cycle (5 hours) has been completed, the “System Check” LED will go off and the “System Ready” LED will illuminate. Open the external outlet valve and the generator will supply ultra high purity nitrogen to the application. Check all downstream piping connections for leaks using a bubble-type leak detecting solution.

If there is a power or pressure interruption, the “System Check” LED will go on and the system may go back into a start-up mode. (See “Power Interruptions” and “Pressure Interruptions” sections below). If the “System Ready” LED indicator goes off and the “Service System” LED indicator is illuminated or blinking, the operator should check the hydrocarbon catalyst module (Model 26000-008 only). It may need to be replaced as part of the normal maintenance of the hydrocarbon catalyst module, or it may have a loose electrical connection (see the Troubleshooting Section at the end of this bulletin).

Pressure Interruptions

If the compressed air pressure falls below 60 psig (4.1 barg), an internal pressure transducer will activate an audible alarm and the yellow “System Check” light will be illuminated to attract operator attention. If the pressure remains below 60 psig (4.1 barg) for less than 6 minutes (time required for purge and fill of PSA towers), the system will continue to operate at rated flow and purity. If the inlet air pressure drops below 60 psig (4.1 barg) for more than 6 minutes, the internal outlet valve will close and the flow of nitrogen will cease. After this low pressure condition is corrected, the outlet valve will open and the nitrogen flow will start again immediately.

Power Interruptions

If the electrical power is interrupted for less than 30 minutes, the system will deliver nitrogen at rated flow and purity when the power returns. If the power is interrupted for between 30 and 60 minutes, the generator will go into an abbreviated 1 hour start-up cycle when the power returns. If the power supply is interrupted for more than 1 hour, the initial 5 hour start-up cycle will be repeated when the power returns.

Flow Rate Adjustment

The flow of nitrogen from the VWR UHP Nitrogen Generator must be controlled using a metering valve or flow controller downstream from the unit. The flow control device may be integral to the equipment being used downstream, or it may be an independent controller (see Installation Section) purchased and installed by the customer. In either case, a device to measure the flow should also be installed (either with the flow controller or downstream from the application). If the demand of ultra high purity nitrogen exceeds the delivery capacity of the generator, the purity and pressure of the emergent nitrogen stream will not meet specifications.

The outlet pressure and flow from the generator must be adjusted according to the operating parameters listed below. If the outlet flow exceeds the rated flow for a given inlet pressure, the nitrogen purity will not meet specifications.

Outlet Flow Operating Parameters

Minimum Inlet Pressure		Maximum Outlet Flow	Maximum Outlet Pressure		Receiver Pressure*	
120 psig	8.3 barg	1.1 lpm	85 psig	5.9 barg	90-115 psig	6.2-7.9 barg
110 psig	7.6 barg	1.0 lpm	75 psig	5.2 barg	80-100 psig	5.5-6.9 barg
100 psig	6.9 barg	0.9 lpm	65 psig	4.5 barg	70-90 psig	4.8-6.2 barg
90 psig	6.2 barg	0.8 lpm	60 psig	4.1 barg	65-80 psig	4.5-5.5 barg
80 psig	5.5 barg	0.7 lpm	50 psig	3.4 barg	56-73 psig	3.9-5.0 barg
70 psig	4.8 barg	0.6 lpm	45 psig	3.1 barg	50-64 psig	3.4-4.4 barg
60 psig	4.1 barg	0.5 lpm	35 psig	2.4 barg	40-52 psig	2.8-3.6 barg

* Note: During the warmup, receiver pressure gauge reading will be zero.

Shutdown

If the generator will be shut down for longer than a few hours, turn off the power to the generator and close the (customer installed) inlet air valve. Allow the generator to purge for 10 minutes. Open the lower service panel and close the 2-way manual valve upstream from the PSA towers (see Figure 5). Finally, close the external manual outlet valve. **If the generator is not shut down according to this procedure, the PSA towers may be poisoned and the warranty will be void.**



Maintenance



Before servicing the Parker Balston UHP Nitrogen Generator, isolate the unit from the compressed air and electrical power supplies. Allow the generator to cool for at least 2 hours before depressurizing (Model 26000-008 only). All maintenance tasks for the Parker Balston® Nitrogen Generator should be performed by suitable personnel using reasonable care.

The primary maintenance tasks required by the VWR UHP Nitrogen Generator are changing the filter cartridges in the coalescing prefilter and particulate filters (annually), replacing the final membrane filter cartridge (annually), and replacing the hydrocarbon catalyst module (Model 26000-008 only, 3 years). A summary of the replacement part numbers and recommended service frequency is shown at the end of this Maintenance section. See Figure 6 for the locations of the various maintenance items.

Additional coalescing prefilter cartridges, particulate filter cartridges, and membrane filter cartridges for the 26000-008 and 26000-010 Nitrogen Generators may be ordered through your local representative. For convenience, a one-year supply of these replacement cartridges has been assembled into a maintenance kit (82031-478 Maintenance Kit for Model 26000-010 and 82031-476 Maintenance Kit for Model 26000-008).

If necessary, the UHP Nitrogen Generator may be wiped clean with a dry cloth on an as needed basis. **Do not use water, aerosols, or other cleaning agents to clean the unit. The use of any liquid detergent to clean the generator could present an electrical hazard.**



Filter Cartridge Replacement

If the hydrocarbon catalyst module is not being replaced when the filters are replaced, there is no need to allow the generator to cool. The only preparation needed to service the filters is turning off the air supply to the generator and depressurizing the affected filter housings. To depressurize the filter housings, turn off the compressed air supply to the generator and allow the generator to cycle until the inlet pressure gauge reads zero. This should only take 10 minutes (1-2 generator cycles). Turn off power to generator.

The coalescing and particulate filters and the final membrane filter in the UHP Nitrogen Generator are easily accessible when the lower service panel is removed (see Figure 6). These filters should be changed on an annual basis to maintain efficient operation of the system. The filter cartridge in the coalescing prefilter assembly is removed by loosening the bowl from the filter assembly, and unscrewing the element retainer from the base of the cartridge. Insert the new filter cartridge (P/N 100-12-BXE) and reassemble the housing in the reverse order.

The particulate filter(s) and final membrane filter cartridges are easily removed from the housing by unscrewing the filter bowl from the filter head (no tools required). Insert the new filter cartridge (P/N 050-05-BXE or GS050-05-95) and reassemble the filter housing.

Replace the lower service panel after replacing the filter cartridges. The time required to service all stages of filtration integral to the generator is approximately 30 minutes.

Catalyst Module Maintenance (Model 26000-008 only)

Allow at least 2 hours for the generator to cool prior to changing the catalyst module.

The hydrocarbon catalyst module in the Parker Balston UHP Nitrogen Generator is located behind the upper service panel and should be changed approximately every three years (or when the "Service System" LED starts blinking) to maintain the hydrocarbon removal specification for the unit.

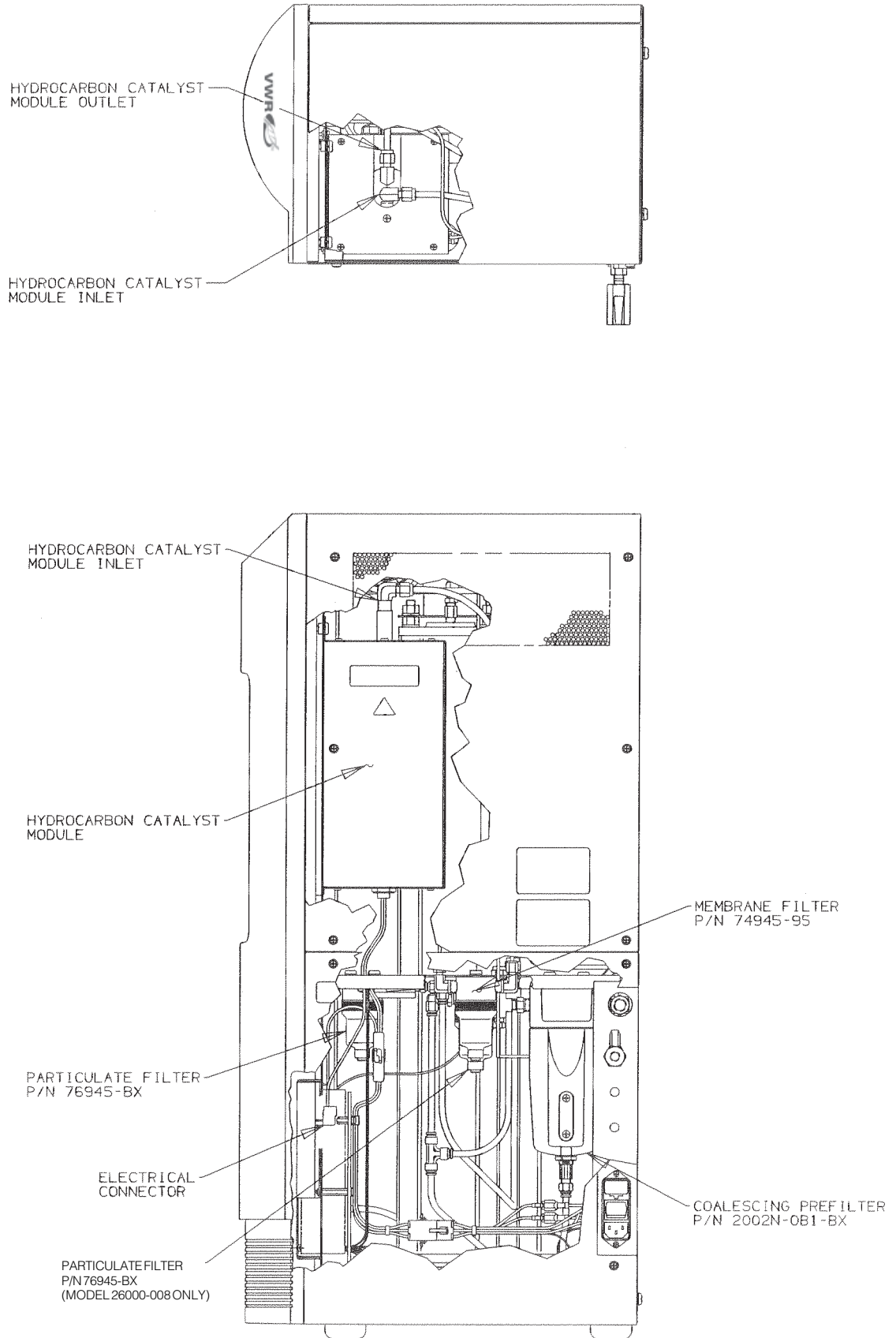

Figure 6 - Maintenance Items

The tools required to change the catalyst module are: a Phillips head screwdriver, two 9/16" wrenches (or adjustable wrenches), and one 1/2" wrench (or adjustable). The procedure for replacing the hydrocarbon catalyst module is as follows:

- 1 Turn off the inlet air supply to the generator. Wait approximately 10 minutes before turning the generator power off. This will allow the generator to depressurize fully.
- 2 Unplug the generator from the power receptacle. **Allow the unit to cool for at least 2 hours before removing the cover.**
- 3 Remove the upper and lower service panels from the 26000-008 (4 Phillips screws) and disconnect the electrical fittings to the hydrocarbon catalyst module at the connectors (see Figure 6).
- 4 Disconnect the two tubing connections to the hydrocarbon catalyst module (see Figure 6) using the wrenches (one as an anchor).
- 5 Remove the two screws which fasten the hydrocarbon catalyst module to the 26000-008 frame.
- 6 Remove the spent module from the 26000-008 and replace with the new module.
- 7 Re-connect the inlet and outlet fittings to the hydrocarbon catalyst module, open the supply air valve, and check for leaks. Re-connect the module's electrical connections. Replace the service panels. Plug the generator back into the wall receptacle.
- 8 Restart the 26000-008 by switching the power on. The generator will begin its 5 hour warm-up.

Fuse Replacement



Occasionally, one or both of the fuses in the UHP Nitrogen Generator may burn out. The fuse located in the hydrocarbon removal module power harness is rated for 50 mA. **This is not a field-serviceable fuse and should not be removed under any circumstances.** The main fuses are located in the power receptacle on the side of the generator. **Before servicing the main fuses, turn the generator off and disconnect the power cord from both the power supply and the generator power receptacle.**



To access the main fuses, use a small screwdriver to remove the fuse holder located in the power receptacle of the generator. In the UHP Nitrogen Generator, both the phase and neutral are fused separately. As a result of these configuration, both fuses should be checked any time fuse replacement is warranted. **Replace either one or both fuses as necessary and re-assemble. To maintain the safety and performance integrity of the product, use only fuses of the size and type detailed in the specifications section of this bulletin.**



This equipment has main fuses in both neutral and phase lines. Use care when servicing.

Ordering Information

	1st Stage	2nd Stage	3rd Stage (26000-008 only)	Final Filter	Hydrocarbon Catalyst Module
Replacement P/N	100-12-BXE	050-05-BXE	050-05-BXE	GS050-05-95	76133
Change Frequency	Annual	Annual	Annual	Annual	3 years
Maintenance Kit - Model 26000-010	82031-478				
Maintenance Kit - Model 26000-008	82031-476				

System Specifications	26000-010	26000-008
IEC 1010 Installation	Category II	▶
IEC 1010 Pollution	Degree 2	▶
CSA Certification Standard	CAN/CSA 22.2 No. 1010-92	▶
IEC Safety Standard	IEC 1010-1:1990+ A1 1992+ A2:1995/ENG1010-1:1993	
UL Safety Standard	UL3101-1, First Edition	
UL Listed to U.S. and Canadian Safety Standards		
Nitrogen Purity	99.9999%	99.9999%
O ₂ , H ₂ O, CO ₂ Concentration	< 1.0 ppm	< 1.0 ppm
Hydrocarbon Concentration	N/A	< 0.1 ppm
Ar Concentration	0.9%	0.9%
Inlet Connection	1/4" NPT (female)	1/4" NPT (female)
Outlet Connection	1/8" NPT (female)	1/8" NPT (female)
Compressed Air Consumption	1.5 SCFM (42 lpm)	1.5 SCFM (42 lpm)
Min/Max Inlet Air Pressure (5)	60 psig/125 psig (4.1 barg/8.6 barg)	60 psig/125 psig (4.1 barg/8.6 barg)
Recommended Inlet Air Temperature	78°F (26°C)	78°F (26°C)
Altitude	2000 m	2000 m
Max. Ambient Relative Humidity	80%	80%
Ambient Operating Temperature	60°F to 100°F (16°C to 38°C)	60°F to 100°F (16°C to 38°C)
Electrical Requirements	120VAC / 230VAC, 50/60 Hz, 25 watts	120VAC / 230VAC, 50/60 Hz, 700 watts
Dimensions	12"w X 16"d X 35"h (31cm X 41cm X 89cm)	12"w X 16"d X 35"h (31cm X 41cm X 89cm)
Shipping Weight	110 lbs. (50 kg)	110 lbs. (50 kg)
Fuse Type (120 VAC Model) (230 VAC Model)	1 amp, Type T, 250 V 1 amp, Type T, 250 V	4 amp, Type T, 250 V 3.15 amp, Type T, 250 V

Table 1

Nitrogen Outlet Pressure and Flow Specifications

Inlet Air Pressure		Maximum N ₂ Flow	Maximum N ₂ Pressure	
125 psig	8.6 barg	1.1 lpm	85 psig	5.9 barg
110 psig	7.6 barg	1.0 lpm	75 psig	5.2 barg
100 psig	6.9 barg	0.9 lpm	65 psig	4.5 barg
90 psig	6.2 barg	0.8 lpm	60 psig	4.1 barg
80 psig	5.5 barg	0.7 lpm	50 psig	3.4 barg
70 psig	4.8 barg	0.6 lpm	45 psig	3.1 barg
60 psig	4.1 barg	0.5 lpm	35 psig	2.4 barg

Optional Accessories

	P/N
Indicating Oxygen Trap (3)	72092
Prefilter, if needed	2002N-1B1-DX
Pressure Regulator (upstream)	72-130-V883
Pressure Regulator (downstream)	W-425-4032-000
Surge Suppressor	75043 (North America) 75044 (Europe)
Hydrocarbon Scrubber	76080

Notes

- The VWR UHP Nitrogen Generator was designed to meet the specifications listed when operated in a manner consistent with the recommendations presented in this manual. If these operating specifications are not met, then inferior product performance and shortened product life may result.
- The nitrogen generator should be run continuously to optimize the performance and reliability of the unit.
- Install the 72092 Oxygen Indicating Trap in a vertical position to avoid channeling within the catalyst. If installed horizontally, and channeling occurs, the effectiveness of the trap will be significantly reduced.
- The VWR UHP Nitrogen Generator installation should be thoroughly checked for leaks after any service activity has been performed on the system in particular or its installation on the whole. Any leak could significantly reduce the purity of the outlet nitrogen stream.
- The VWR UHP Nitrogen Generator will not operate with an inlet air pressure less than 60 psig (4.1 barg). A pressure regulator must be installed upstream from the generator to maintain an air supply pressure of 60 psig to 125 psig (4.1 barg to 8.6 barg).

Cautions



Nitrogen is nontoxic and largely inert. It can act as a simple asphyxiant by displacing oxygen in air. Inhalation of nitrogen in excessive concentrations can result in unconsciousness without any warning symptoms such as dizziness, fatigue, etc.

Troubleshooting

Symptom

Course of Action

High oxygen content in outlet nitrogen

Check inlet pressure and outlet flow rate. Verify that flow demand is equal to or less than flow capacity.
 Check fittings between system and point of use for leaks.

High hydrocarbon content of outlet nitrogen (Model 26000-008 only)

Check flow rate at system outlet.
 Check fittings between system and point of use for leaks.
 Replace hydrocarbon catalyst module.

Low pressure at nitrogen outlet

Check inlet air pressure.
 Check system for leaks.
 Check flow rate at system outlet. Verify that flow demand is equal to or less than flow capacity.
 Replace final filter.

Indicating oxygen trap turns brown rapidly

Check flow rate at system outlet. Verify that flow demand is equal to or less than flow capacity.
 Check system for leaks.
 Replace indicating oxygen trap.

No outlet flow/pressure

Check power supply.
 Check inlet pressure.
 Check particulate filter downstream from the hydrocarbon module. If it is corroded, consult the factory.

Don't Forget To:

- 1 Complete and mail your registration card.
- 2 Keep your product certification in a safe place.
- 3 Call the Technical Services Department at **800-932-5000**, 8 AM to 5 PM Eastern Time (North America only) with any questions. For other locations, please contact your local representative.

Serial Numbers

The serial number for the unit is located at the bottom corner of the side panel, opposite the power receptacle. For your own records, and in case service is required, please record the following:

DATE IN SERVICE _____ SERIAL NO. _____

VWR International
 1310 Goshen Parkway
 West Chester, PA 19380

Prices, product appearance and specifications are current at the time of printing, subject to change without notice. Availability for certain products may be limited by federal, state, provincial or local licensing requirements. All prices are in U.S. dollars unless otherwise noted. Offers valid in USA, void where prohibited by law or company policy, while supplies last. Visit vwr.com to view our privacy policy and additional disclaimers.

©2006 VWR International, Inc. All rights reserved. Printed in U.S.A.

Copyright© VWR International, Inc. All Rights Reserved.
 Printed in U.S.A. August 2006, April 2007
 Bulletin TI-N2-1100-L1466A

Symbol

Description



Caution, refer to accompanying documents for explanation.

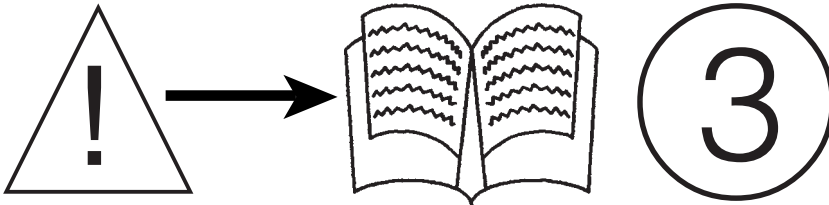

Refer to Installation and Operation Manual, warning note #3 for explanation.



Caution, risk of electric shock.



Surface may be hot and could cause burns to the skin (found on inside of some units).



Under certain conditions, metal cabinet will be warm to touch (70°C).



vwr.com 1.800.932.5000

Order from Over 1,000,000 Products

VWR International
1310 Goshen Parkway
West Chester, PA 19380

Prices, product appearance and specifications are current at the time of printing, subject to change without notice. Availability for certain products may be limited by federal, state, provincial or local licensing requirements. All prices are in U.S. dollars unless otherwise noted. Offers valid in USA, void where prohibited by law or company policy, while supplies last. Visit vwr.com to view our privacy policy and additional disclaimers.

©2006 VWR International, Inc. All rights reserved. Printed in U.S.A.

Copyright© VWR International, Inc. All Rights Reserved.
Printed in U.S.A. August 2006, April 2007
Bulletin TI-N2-1100-L1466A