

Part Nos.
EH0-3121
EH0-3122

phenomenex[®]

TABLE OF CONTENTS

Introduction	1
How It Works	2-3
Recycling	2
Validation Output	3
AutoClean Accessory	3
Instrument Description	4-7
Front View	4-5
Rear View	6-7
Installation	8-10
Definition of Programming Terms	11-13
Mode of Operation	11
Method	11
Detector Output Voltage	11
Detector Type	11
Display Units	12
Threshold Value	12
Valve Delay	12
Wash Delay Time	12
Equilibration Mode	12
Pump Off	12
Microprocessor Programming Flowchart	13
Microprocessor Programming Flowchart with AutoClean	14
Operation	15
Additional Information	15
Selection of Solvent Containers	15
Mobile Phase Shelf Life	15
Wash Solvent Selection	15
Tubing and Fittings	15
Instrument Storage and Care	15
Appendices	16-21
A. Cable Formats	16
B. Troubleshooting Flowchart	17-18
C. Replacement Parts	19
D. Diagram of the Control Module Electronics	20
E. Diagram of the Control Module Electronics With AutoClean	21
Warranty	22
Damaged Shipments	22

INTRODUCTION

The Solvent Recycler reduces mobile phase consumption while maintaining the purity of the mobile phase. It operates on-line using the detector signal and an electrically actuated valve installed between the detector and the waste reservoir. The Solvent Recycler monitors the detector signal to determine when peaks and other contaminants are eluting from the system. As soon as a contaminant is detected, the Recycle Valve (V1) diverts contaminated mobile phase to WASTE. When no contaminants are present, the Recycle Valve (V1) sends clean solvent back to the mobile phase reservoir for reuse.

An optional AutoClean Accessory performs a pre-programmed post-run system wash, re-equilibration, and shutdown using a Wash Valve (V2) and our exclusive Solvent Recycling/AutoClean software. This extends the life of the instrument and column by automatically washing out damaging buffers and other harsh mobile phase components. At the end of an analysis, the wash solvent of your choice is delivered to the HPLC pump for a complete system wash. A mobile phase re-

equilibration period may be programmed to occur after the system wash. Pump shutdown may be programmed to occur at the end of either the wash or the re-equilibration period. This combination of features automatically cleans, re-equilibrates and shuts down the HPLC system without operator attention.

A bright, back-lit LCD display and four front-panel keys provide an intuitive user interface. For regulatory and GMP compliance, the Recycler sends a copy of the chromatographic signal, superimposed with tick marks indicating Recycle Valve (V1) position, through the Validation Output. Connect this output to a recorder or other logging device to generate an auditable Recycler-performance data trail.

This instrument has a proven track record of running unattended day after day, without affecting chromatographic performance or mobile phase purity. The Solvent Recycler is compatible with all isocratic methods and is easy to install and use.

WARRANTY

Phenomenex warrants this product against defects in workmanship or material under normal use or service for three years, except the switching valve, which is warranted for one year. All obligations or liabilities under this warranty are limited to repair or replacement, at Phenomenex's option, F.O.B. location of shipment of parts that are returned, freight prepaid and which are accepted as being defective upon inspection by Phenomenex.

Components that are subject to normal wear and/or are scheduled for routine replacement within the warranty period, and/or parts, which are subjected to effects of corrosion or deterioration by chemical or other action, are excluded from the above warranty. Repair or replacement will not be made under warranty for malfunction due to inadequate facilities, operating conditions or utilities. The switching valve, which is warranted for one year, is also excluded from the three-year warranty.

Equipment and components may only be returned with Phenomenex's prior approval and must bear a Phenomenex Return Authorization Number.

Guarantees/Warranties on accessories and equipment included by/from other manufacturers are limited to the guarantees given on such equipment by the respective manufacturers. Any modifications made to equipment covered by this warranty, without written permission from Phenomenex, will void the warranty. Phenomenex reserves the right not to honor this warranty if the products are obviously mishandled by the user.

Phenomenex assumes no responsibility for consequential, economic or incidental damages of any nature or on-site reinstallation costs arising out of future alleged failure of any of its products or their accessories.

This warranty supersedes any and all previous warranties unless otherwise agreed upon at the time of sale, such as for customized equipment.

DAMAGED SHIPMENTS

The Interstate Commerce Commission has held that carriers are responsible for both concealed and visible damage occurring during transit. Unpack shipment promptly after receipt as there may be concealed damage, even though no evidence of it is apparent. If concealed damage is discovered, cease further unpacking of the unit involved and request immediate inspection by the local agent of the carrier and secure a written report of the findings to support a claim. This request must be made within 15 days of receipt, or the claim will not be honored by the carrier. Do not return damaged goods to the factory without first securing an inspection report and contacting Phenomenex or authorized dealer for a Return Authorization Number.

FILING OF CLAIMS

After a damage inspection report has been secured, Phenomenex will cooperate in replacing damaged goods and in handling of claims which have been initiated by either party.

HOW IT WORKS

The Solvent Recycler reduces mobile phase consumption by sending clean detector effluent back to the mobile phase reservoir for reuse. The Solvent Recycler uses the detector signal and METHOD software parameters to control a two-position Recycle Valve (V1) installed immediately downstream from the detector (Figure 1). The Recycle Valve (V1) diverts contaminated detector effluent (mobile phase that carries chromatographic peaks) to waste and recycles only the clean portion of the mobile phase. An optional AutoClean Accessory allows a programmable, automated system wash followed by re-equilibration and pump shutdown.

RECYCLING

There are three Modes of Operation: AUTOMATIC, MANUAL, and REMOTE. In the AUTOMATIC mode, valve position is determined by the detector signal and the method parameters. In the MANUAL Mode, valve position is selected by the analyst through the front panel key pad. In the REMOTE Mode, an external device selects valve position.

In the AUTO Mode the detector signal and METHOD parameters, DETECTOR OUTPUT VOLTAGE, THRESHOLD, VALVE DELAY, DETECTOR TYPE, and DISPLAY UNITS determine when solvent is recycled. Up to 10 METHODS may be stored for easy recall or modification. The DETECTOR OUTPUT VOLTAGE matches the Solvent Recycler input electronics with the detector output signal. The THRESHOLD

is the detector signal level which, when exceeded, causes the Recycle Valve (V1) position to change to WASTE. The valve position returns to RECYCLE after the detector signal falls below the THRESHOLD value and the VALVE DELAY time has elapsed. VALVE DELAY time holds the valve in the WASTE position for up to 99 seconds after the detector signal drops below the THRESHOLD Value. The VALVE DELAY time is used to account for tailing peaks and plumbing volume between the detector and the valve. The DETECTOR TYPE is used to determine whether only positive peaks or both positive and negative peaks are sent to WASTE. The DISPLAY UNITS parameter selects the units in which the detector signal and the THRESHOLD are displayed.

The chromatograms in Figures 2A and 2B show how these parameters are used to recycle mobile phase. In Figure 2A the THRESHOLD value is 1%, VALVE DELAY is 20 seconds, and the DETECTOR TYPE is set to +, since there are only positive peaks in the chromatogram. Note how the VALVE DELAY is used to divert the tailing portion of peak #3 to WASTE, even though the detector signal during the tail is below the THRESHOLD value. In this example approximately 75% of the mobile phase is recycled.

In Figure 2B both positive and negative peaks are present in the chromatogram. The DETECTOR TYPE is set to the ± mode, sending both the positive and negative peaks to WASTE.

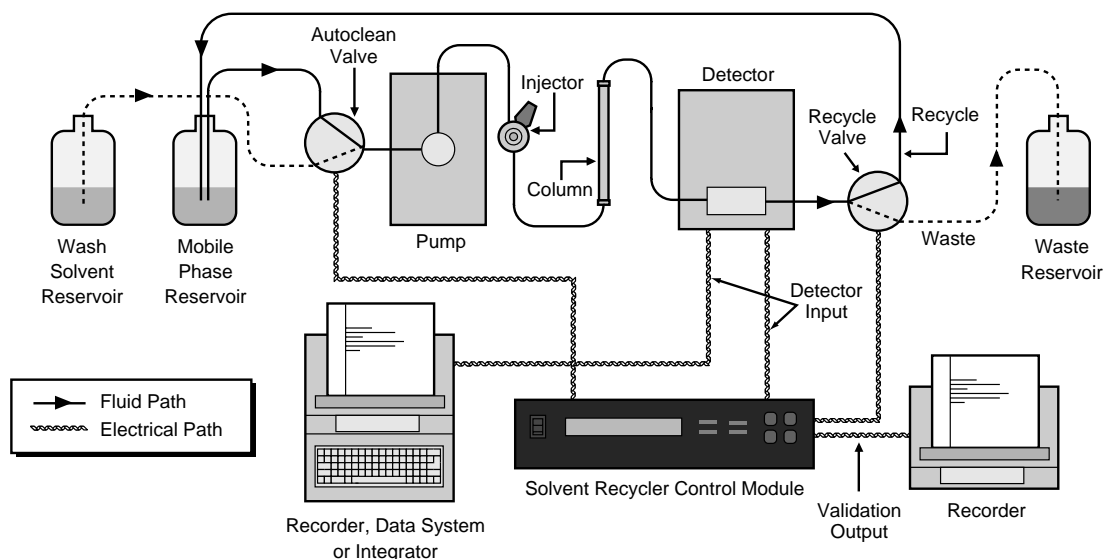

Figure 1 - The Solvent Recycler is composed of a control module, a Recycle Valve, and an optional AutoClean Valve. The Recycle Valve is installed downstream from the detector. The AutoClean Valve is installed upstream from the pump. Both valve positions are regulated by our exclusive recycling software. The Validation Output is sent to a secondary recording device for a separate data trail of Recycle Valve position.

VALIDATION OUTPUT

For method development, regulatory and GMP compliance, the Recycler sends a copy of the chromatographic signal, superimposed with tick marks indicating Recycle Valve (V1) position, through the Validation Output. Connect this output to a recorder or other logging device to generate an auditable Recycler-performance data trail.

AUTOCLEAN ACCESSORY

This option can be purchased pre-installed when the Recycler is purchased or as a field-upgrade kit (this model recycler only). The AutoClean software performs a pre-programmed post-run system wash, re-equilibration, and shutdown using a Wash Valve (V2) installed between the pump and mobile phase reservoirs (**Fig 1**). At the end of an analysis, the wash solvent of your choice is delivered to the HPLC pump, washing the system for the period specified in the METHOD. A mobile phase re-equilibration period may be programmed to occur after the system wash. Pump shutdown may be programmed to occur at the end of either the wash or the re-equilibration period. During the wash and re-equilibration period, the

AutoClean software sets the Recycle Valve (V1) to the WASTE position so mobile phase is not contaminated. Washing the system regularly extends the life of the instrument and column by washing out damaging buffers and other harsh mobile phase components. AutoClean makes this easy by automatically cleaning, re-equilibrating and shutting down the HPLC system without operator attention. AutoClean works with any isocratic or gradient HPLC pumping system.

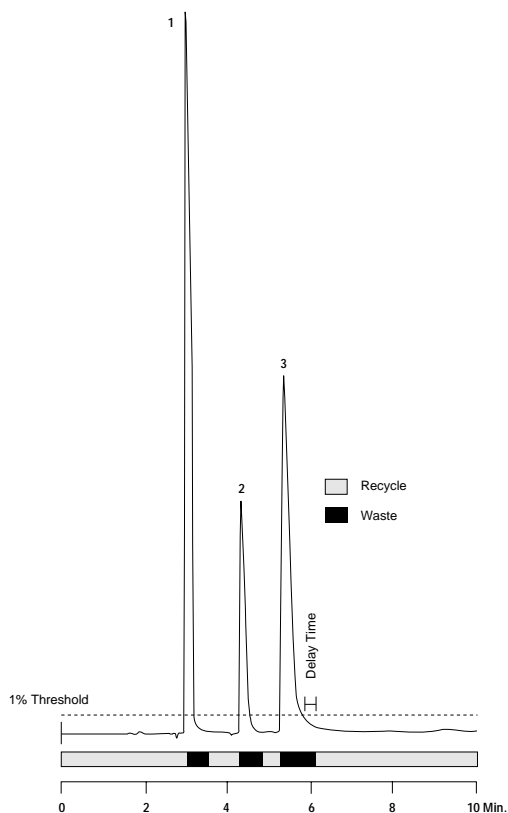

Figure 2A - The Recycled and Waste Portions in a Chromatogram with DETECTOR TYPE set to divert Positive Peaks (+) to Waste.

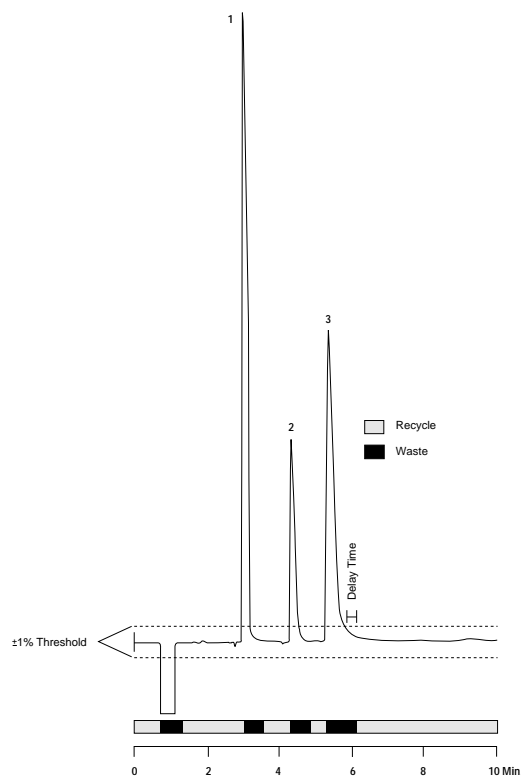

Figure 2B - The Recycled and Waste Portions in a Chromatogram with DETECTOR TYPE set to Divert Both Positive and Negative Peaks (\pm) to Waste.

INSTRUMENT DESCRIPTION - FRONT VIEW

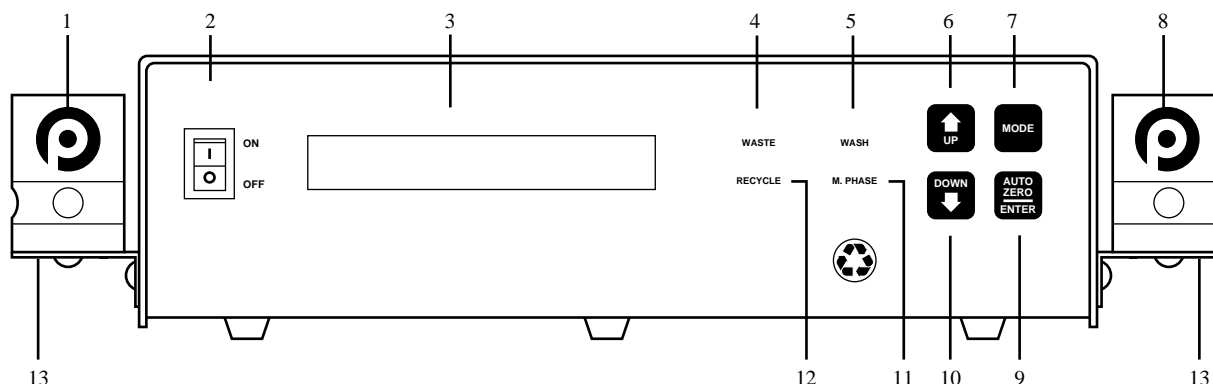

FIGURE 3 - FRONT VIEW - SOLVENT RECYCLER

1. RECYCLE VALVE (V1)

The Recycle Valve (V1) is an electrically actuated two-position spring-loaded valve. Wetted parts are made of polyetheretherketone (PEEK) and Teflon® (PTFE), which are inert to all common HPLC solvents including tetrahydrofuran (THF). The valve can be attached to either side of the control module at one of six locations, or remote from the unit if needed at distances up to 2 feet. Valve position is regulated by the control module in response to the detector signal when in the AUTO Mode, manually from the key pad in the MANUAL Mode, or remotely from an external device when in the REMOTE Mode. The Recycle Valve (V1) has three ports labeled DETECTOR, WASTE, and RECYCLE, respectively. The DETECTOR port receives the detector effluent. The WASTE port directs contaminated mobile phase to the waste reservoir. The RECYCLE port returns clean mobile phase back to the mobile phase reservoir. The Recycle Valve (V1) is in the RECYCLE position when the Solvent Recycler is turned off.

NOTE: Do not interchange the Recycle Valve (V1) and Waste Valve (V2)! The Recycle Valve (V1) flow passages are smaller than the Wash Valve (V2) flow passages.

2. POWER SWITCH

3. LCD DISPLAY PANEL

The backlit LCD display panel is a two-line, 24-character alphanumeric display used for displaying operational real time parameters and programming the microprocessor.

4. WASTE INDICATOR

This indicator is illuminated in red when the Recycle Valve (V1) is in the WASTE position.

5. WASH INDICATOR

This indicator is active only if the AutoClean Accessory is installed. This indicator is illuminated in orange when the Wash Valve (V2) is in the WASH position.

6. UP ARROW KEY



This is a multipurpose programming key. When selecting DETECTOR TYPE, MODE OF OPERATION, and METHOD NUMBER, this key moves the current selection on the display panel one step to the right. When programming DETECTOR OUTPUT VOLTAGE, THRESHOLD, and VALVE DELAY, this key increases the value. If the key is held down continually while programming THRESHOLD and VALVE DELAY, the value will increase rapidly.

7. MODE SELECTOR KEY



Press this key to initiate interactive programming of recycling software. This is used to create or modify a METHOD (see **Figure 5** or **6**).

8. WASH VALVE (V2)

(Included with optional AutoClean Accessory)

The Wash Valve (V2) is an electrically actuated two-position spring-loaded valve. Wetted parts are made of polyetheretherketone (PEEK) and Teflon® (PTFE), which are inert to all common HPLC solvents including tetrahydrofuran (THF). The valve can be attached to either side of the control module at one of six locations, or remote from the unit if needed at distances up to 2 feet. The Wash Valve (V2) has three ports labeled M. PHASE, WASH, and PUMP, respectively. The M.PHASE port receives mobile phase from the mobile phase reservoir. The WASH port receives wash solvent from the wash solvent reservoir. The PUMP port delivers mobile phase or wash solvent to the pump.

NOTE: Do not interchange the Recycle Valve (V1) and Waste Valve (V2)! The Recycle Valve (V1) flow passages are smaller than the Wash Valve (V2) flow passages.

9. AUTO ZERO/ENTER KEY



The Autozero/Enter key performs two functions. During METHOD programming this key functions as an Enter key. At all other times depressing this key will zero the Solvent Recycler electronics. To accurately zero the Solvent Recycler, all other system components should be warmed up and mobile phase should be flowing. When these conditions are met and the detector has been zeroed, depressing the Solvent Recycler Autozero key will match the Solvent Recycler's zero point to that of the detector. Baseline adjustments prior to each injection are best done at the detector. If automatic zeroing is desired and the detector does not have the capability to autozero, the Solvent Recycler Autozero input contacts on the rear panel can be used for this purpose. For instruction on connecting the Autozero contacts, see INSTRUMENT DESCRIPTION - REAR VIEW.

10. DOWN ARROW KEY



This is a multipurpose programming key. When selecting DETECTOR TYPE, MODE OF OPERATION, and METHOD NUMBER, this key moves the current selection on the display panel one step to the left. When programming DETECTOR OUTPUT VOLTAGE, THRESHOLD, and VALVE DELAY, this key decreases the value. If the key is held down continually while programming THRESHOLD and VALVE DELAY, the value will decrease more rapidly.

11. MOBILE PHASE INDICATOR

This indicator is active only if the AutoClean Accessory is installed. This indicator is illuminated in green when the Wash Valve (V2) is in the MOBILE PHASE position.

12. RECYCLE INDICATOR

This indicator is illuminated in green when the Recycle Valve (V1) is in the RECYCLE position.

13. VALVE BRACKET

The valve bracket attaches the valve to the control module at any of six positions.

INSTRUMENT DESCRIPTION - REAR VIEW

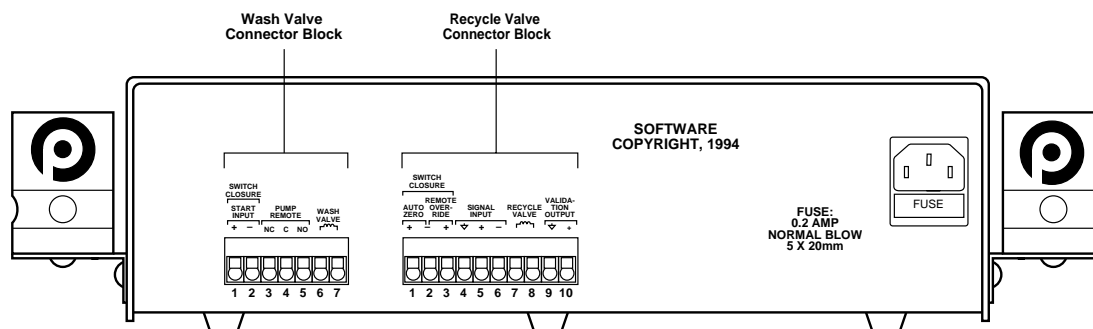

FIGURE 4 - REAR VIEW - SOLVENT RECYCLER

1. RECYCLE VALVE CONNECTOR BLOCK TERMINALS 1 - 10

CAUTION: Do not apply line voltage to the terminal strip. This will result in permanent damage to the control module.

TERMINALS 1 and 2, AUTOZERO

The Remote Autozero function is used in conjunction with detectors which do not have remote autozero capability. The Solvent Recycler Remote Autozero can be triggered by an external device, such as an autosampler, through a signal cable connected to terminals 1 and 2 of the Recycle Valve connector block. The Solvent Recycler's Autozero circuit will be enabled when the remote device sends a 50msec (minimum) contact closure or TTL signal. The external device must be able to switch 5 VDC at 10 milliamps.

TERMINALS 2 and 3, REMOTE OVERRIDE

The Remote Override is used to control the Recycle Valve (V1) position from a remote device. The Remote Override is triggered by an external device through a signal cable connected to terminals 2 and 3 of the Recycle Valve (V1) connector block. The external device must be able to switch 6.5 VDC at 10 milliamps.

When the circuit is closed, the valve position is switched to WASTE. When the circuit is opened, the valve position is switched to RECYCLE, if the control module is in the REMOTE mode. If the AUTO mode is selected, the valve position will be determined by the detector signal and the METHOD parameters when the circuit is opened.

TERMINALS 4, 5, and 6, SIGNAL INPUT

The Control Module receives an analog signal from the detector through terminals 4, 5, and 6. This is then converted to a digital signal for the microprocessor. The supplied single-ended signal cable should be connected from terminals 5 (+) red, 6 (-) black, and 4 (shield) silver to the detector signal output. If the detector has a unique cable or does not have a

compatible spade terminal, then the signal cable provided with the Solvent Recycler and the detector cable can be connected together with a terminal block. If the detector has a differential output, purchase a differential signal cable (Appendix C). Use only the supplied cable or the alternative differential signal cable with the Solvent Recycler.

TERMINALS 7 and 8, RECYCLE VALVE (V1)

The Recycle Valve (V1) cables are connected to terminals 7 and 8 of the Recycle Valve (V1) connector block. When the Control Module sends a signal to these terminals, the Recycle Valve (V1) WASTE position is selected. When the signal is terminated, the Recycle Valve (V1) RECYCLE position is selected.

NOTE: When power is off, the valve is in the RECYCLE position.

TERMINALS 9 and 10, VALIDATION OUTPUT

For method development, regulatory and GMP compliance, the Recycler sends a copy of the detector signal, superimposed with tick marks indicating Recycle Valve (V1) position, through the Validation Output. Connect terminals 9 and 10 to a recorder or other logging device to generate an audible Recycler-performance data trail. Each time the Recycle Valve (V1) is activated (flow is to WASTE), a single tick mark (at 10% of full scale) is generated on the chromatogram. When the Recycle Valve (V1) is deactivated (solvent flow is to Recycle) two tick marks, separated by two seconds, are generated on the chromatogram.

The Validation Output full scale signal is equal to the DETECTOR OUTPUT VOLTAGE selected in the METHOD, except when the 10V range is selected. In this case, the Validation Output is set at 2V full scale.

NOTE: Use the original detector signal for integration and data analysis. Do not use the Validation Output for this purpose, since the valve position tick marks will interfere with integration.

2. WASH VALVE CONNECTOR BLOCK TERMINALS 1 - 7

These terminals function only when the AutoClean Accessory is installed.

CAUTION: Do not apply line voltage to the terminal strip. This will result in permanent damage to the control module.

TERMINALS 1 and 2, START INPUT

The Start Input terminals are used to initiate a system wash at the end of an unattended run. The system wash occurs only if a Wash Delay is programmed into the METHOD. The beginning of the wash is triggered by a contact closure or TTL signal across terminals 1 and 2 of the Wash Valve connector block. The signal must be held for a minimum of 200 milliseconds before the AutoClean Mode will be activated.

TERMINALS 3, 4, and 5, PUMP REMOTE

A switch signal (NO and NC) occurs across these terminals at the end of a Wash or Re-equilibration period, if programmed in the METHOD. This signal may be used to shut down the pump after the Wash or Re-equilibration period. Connect terminals 3 and 4 to the pump if it requires a contact closure to shut down. Connect terminals 4 and 5 to the pump if it requires an open circuit to shut down.

NOTE: If the ENTER key is pressed during the wash or equilibration cycles, pump shutdown will not occur.

TERMINALS 6 and 7, WASH VALVE (V2)

Terminals 6 and 7 are used to connect the Wash Valve (V2) to the control module. When the control module sends a signal through these terminals, the Wash Valve (V2) switches to the WASH position. When the signal is terminated, the Wash Valve (V2) returns to the M. PHASE position.

3. POWER INPUT/FUSE COMPARTMENT

WARNING: ELECTRICAL HAZARD!
Always turn off power and disconnect power cable prior to accessing fuse compartment.

The Control Module houses an internal universal power supply that automatically operates from a line voltage source of 90 VAC to 240 VAC, 50 or 60 Hz.

The fuse compartment contains two 5 x 20mm, 250VAC, 0.2 Amp fuses, one active and the other a replacement. To access the fuse compartment, pry open the slide-out drawer using a small screwdriver. The active fuse is in the innermost position; the spare fuse is in the outermost position.

INSTALLATION

GENERAL

The Solvent Recycler measures 13" x 7.5" x 2.5" (L x W x H), and weighs 5.5 lbs. During installation, please refer to **Figures 3 and 4** and the following sections: "Instrument Description - Front View" and "Instrument Description - Rear View."

INSPECTION AND UNPACKING

Carefully unpack and inspect the Solvent Recycler to insure that all items have been received and no damage has occurred. Included in the box are: One control module with a pre-mounted Recycle Valve (V1), a PEEK union with fittings and tubing already connected, one power cord, one single-ended signal cable, a Validation Output cable, an Autozero cable, and this Operator's Manual.

If the optional AutoClean Accessory was purchased with the Solvent Recycler, the following additional items will be included in the box: a Wash Valve (V2) mounted on a bracket, a 10 ft. length of 1/8" O.D. x 1.5mm I.D. Teflon tubing, three ¼-28 Waters tubing adapters, six 1/8" Flange-Free™ nuts and bushings, three line tags, a 7-position connector block, a Wash Start cable, and a Pump Remote Stop cable.

Not all of the fittings and tubing supplied with the AutoClean accessory are required for installation. The ¼-28 Waters tubing adapters are used only with Waters pumps and 3mm I.D. tubing (not supplied). Installation on most other pumps will use the Flange-Free fittings and 1/8" O.D. x 1.5mm I.D. Teflon tubing.

TOOLS REQUIRED

- 1- 3/16" slotted screwdriver
- 1- #2 Phillips screwdriver

INSTRUMENT LOCATION

Locate the Control Module as close as possible to the detector.

RECYCLE VALVE (V1) LOCATION

The Recycle Valve (V1) should be located on the control module in a position nearest the detector fluid outlet. To relocate the valve, loosen the two Phillips screws connecting the valve bracket to the control module. Choose a new position for the valve and loosen the two corresponding screws, seat the valve bracket on the screws, and tighten the screws. For example, if the control module is on top of a detector with the detector flow cell outlet to the right, position the valve on the right side of the control module.

If the AutoClean Accessory is installed, continue with the following connection; otherwise, continue with the "Power Requirements" Section.

WASH VALVE (V2) LOCATION

The Wash Valve (V2) may be located on either side of the Control Module in any position not occupied by the Recycle Valve (V1). Select a mounting position and loosen the corresponding pair of Phillips-head screws. Seat the Valve bracket on the screws and tighten the screws.

POWER REQUIREMENTS

WARNING - SHOCK HAZARD!

Before changing a fuse, turn off the power and disconnect the power cord from the power source.

The power receptacle should match the supplied parallel blade three-prong power plug. If it doesn't, please contact Technical Service for an appropriate power cable. The universal power supply operates from any line voltage source between 90 VAC and 240 VAC, 50 or 60 Hz. The unit is protected by a single 0.2 amp, 250VAC slow blow fuse. See "Instrument Description, Rear View" for instructions on accessing and replacing fuses.

SIGNAL CABLE CONNECTION

Prior to signal cables installation, it is important to understand the features controlled by these cables. Refer to sections "Instrument Description" and "Definition of Programming Terms". Both the Recycle Valve and Wash Valve connector blocks are removable terminal strips located on the back of the control module. The connector blocks are numbered to correspond to the numbers printed on the rear panel. The Recycle Valve connector block is labeled 1 - 10 and the Wash Valve connector block is labeled 1 - 7. Each connector block is keyed and will fit into the rear panel in only one way.

To Connect Cables to the Connector Block:

1. Remove the connector block assembly by pulling it away from the instrument.
2. Loosen the screws corresponding to the appropriate numbered slot by turning the screw counterclockwise with a slotted screwdriver.
3. Insert the bare wire into the correct slot.
4. Tighten the screw clockwise until the wire is held snugly. Check this by gently tugging on the wire. If it pulls out, repeat steps 2 - 4.
5. After all the connections are made, plug the connector block into the appropriate spot on the rear panel.

NOTE: Refer to **Fig. 4**, "Recycle Valve Connector Block" and **Appendix A**, "Cable Formats", for all connections described in the following paragraphs. A magnetic label imprinted with the terminal block diagram is located on the top of the Control Module.

RECYCLE VALVE (V1)

This cable establishes a connection from the control module to the Recycle Valve (V1). Check the drive connection (Terminals 7 and 8) to insure they are secure. Tighten if necessary.

SIGNAL INPUT

This cable carries the detector signal to the Solvent Recycler. Connect the supplied single-ended signal cable from the detector to terminals 5 (+, red), 6 (-, black), and 4 (shield, silver) on the Recycler. If the detector signal output connection will not accept the cable supplied with the Solvent Recycler, join an appropriate cable from the detector with the Solvent Recycler signal cable using a terminal block. If the detector has a differential output, purchase a differential signal cable (Appendix C).

REMOTE OVERRIDE

The Override cable carries a signal from an external device to the Solvent Recycler to control the Recycle Valve (V1) position. Connect the optional Override cable from an external controlling device to terminals 2 (-, black) and 3 (+, red) on the Recycler. The external device must be able to switch 5 VDC at 10 milliamps. The Override cable is an optional item supplied separately from the Solvent Recycler (Appendix C).

REMOTE AUTOZERO

The Autozero cable allows an external device to zero the Solvent Recycler. Connect the supplied Autozero cable from an external controlling device to terminals 1 (+, red) and 2 (-, black) on the Recycler. A contact closure or TTL signal (50msec minimum length) will initiate the Autozero function. The external device must be able to switch 6.5 VDC at 10 milliamps.

NOTE: If the detector has an autozero function, using the Recycler Autozero is unnecessary as the Recycler electronics will follow the detector signal.

VALIDATION OUTPUT

The Validation Output cable sends a copy of the detector signal, via the Solvent Recycler, to a strip chart recorder. This Validation Output chromatogram is overlaid with tick marks each time the Recycle Valve (V1) position changes. Connect the supplied Validation Output cable from terminals 9 (ground) and 10 (+) on the Recycler to a recorder.

If the AutoClean Accessory is installed, continue with the following connections; otherwise, continue with the Fluid Connection Section.

NOTE: Refer to **Fig 4**, "Wash Valve Connector Block" and Appendix A, "Cable Formats" for all connections described in the following paragraphs. A magnetic label imprinted with the terminal block diagram is located on the top of the Control Module.

WASH VALVE (V2)

This cable establishes a connection from the Control Module to the Wash Valve (V2). Check the drive connection (Terminals 6 and 7) to insure they are secure. Tighten if necessary.

WASH START

The Wash Start cable is required to initiate the Wash Mode. Connect the supplied Wash Start cable from an external controlling device to terminals 1 (+) and 2 (-) on the Recycler. The external controlling device must send a contact closure for a minimum of 200 milliseconds to activate the AutoClean Wash Mode.

PUMP REMOTE

The Pump cable is required to shut off the pump at the end of the Wash or Re-equilibration cycle. Connect the Pump cable from either terminals 3 and 4 or 4 and 5 of the Recycler to the appropriate contacts on your pump. The configuration for cable connection depends on the type of signal required by the pump for remote shutdown. If the pump requires a contact closure, connect the positive wire to position 5 (normally open-NO) and the negative wire to position 4 (common-C). If the pump requires an open circuit, connect the negative wire to position 4 (C) and the positive wire to position 3 (normally closed-NC).

FLUID CONNECTIONS

RECYCLE VALVE (V1)

The RECYCLE, WASTE, and DETECTOR ports are labeled on the Recycle Valve (V1). Submerge the open end of the RECYCLE tubing into the mobile phase reservoir and place the open end of the WASTE tubing into the waste reservoir. To reduce evaporation of the recycled mobile phase, insure that the end of the RECYCLE tubing is placed at the bottom of the mobile phase reservoir.

The supplied tubing and Recycle Valve (V1) may be used with flow rates up to 50mL/min. If flow rates greater than 50mL/min are needed, please contact Technical Service.

If tubing other than that supplied with the Solvent Recycler is used on the Recycle Valve WASTE and RECYCLE ports, it must be 0.030" (0.75mm) I.D. or larger to minimize backpressure on the valve. The tubing from both outlet ports should be kept of equal length to minimize backpressure differential on the valve ports.

Connect the 1/16" O.D. x 0.010" (0.25mm) I.D. Teflon tubing from the valve's DETECTOR port to the fluid outlet of the detector using the supplied union. Minimize the length of this tubing. The volume of solvent in this tubing affects VALVE DELAY selection (i.e., long tubing will increase the required VALVE DELAY).

If tubing other than that supplied with the Solvent Recycler is used on the Recycle Valve (V1) DETECTOR port, it must have an I.D. of 0.010" (0.25mm) or smaller to minimize dead volume. Always consider the pressure resulting from the tubing length and I.D., the flow rate, and mobile phase viscosity. Excessive pressure will damage the detector flow cell.

If the AutoClean accessory is installed, continue with the following connections; otherwise, the Installation is complete and the Solvent Recycler is ready for operation.

WASH VALVE (V2)

The M. PHASE, WASH, and PUMP ports are labeled on the Wash Valve (V2). Connect the existing pump inlet tubing to the Wash Valve (V2) outlet port (labeled PUMP) using a supplied Flange-Free nut and bushing. If connecting to a Waters pump with 3mm I.D. tubing, first tighten a ¼-28 Waters adapter (supplied) into the PUMP port and slide the pump inlet tubing over the adapter. Locate the 1/8" O.D. x 1.5mm I.D. Teflon tubing supplied with the Recycler. Cut two equal lengths tubing for plumbing the mobile phase and wash solvents into the Wash Valve (V2). Connect the tubing to the Wash Valve (V2) using the supplied Flange-Free nuts and bushings. If using 3mm I.D. Waters-type tubing for these lines, first tighten a ¼-28 Waters adapter (supplied) in the M.PHASE and WASH ports and slide the tubing over the adapters. Attach solvent inlet filters (not supplied) to the inlet end of both the mobile phase and wash solvent tubing and submerge in the appropriate solvent reservoir. Installation is now complete. Continue to the Operation section.

DEFINITION OF PROGRAMMING TERMS

MODE OF OPERATION

Choices: Automatic, Manual, or Remote

AUTOMATIC MODE

The AUTO Mode is selected for unattended operation during which the Solvent Recycler Control Module regulates the Recycle Valve (V1) position based on detector signal and user selectable parameters stored in a METHOD. When the detector signal rises above the THRESHOLD, the Recycle Valve (V1) switches to the WASTE position. When the detector signal drops below the THRESHOLD, an internal clock set for the VALVE DELAY starts counting down. The VALVE DELAY accounts for the time it takes a peak to flow from the detector flow cell to the Recycle Valve (V1). When the VALVE DELAY has elapsed, the Recycle Valve (V1) switches back to the RECYCLE position, sending clean mobile phase back to the mobile phase reservoir. If the detector signal rises above the THRESHOLD before the VALVE DELAY expires (e.g., a second peak occurs), the internal clock is reset to the original VALVE DELAY and is held there until the detector signal again drops below the THRESHOLD. The valve remains in the WASTE position until the VALVE DELAY elapses.

The AUTO mode has a REMOTE OVERRIDE feature which is especially useful for automated column washing with a multi-solvent pump. When activated by a contact closure from an external controlling device (through the optional Override cable connected to terminals 2 and 3 of the Recycle Valve [V1] connector block), the Recycle Valve (V1) position is set to WASTE regardless of the detector signal or METHOD parameters. Do not confuse the REMOTE OVERRIDE with the AutoClean Accessory. The REMOTE OVERRIDE is used to hold the Recycle Valve in the WASTE position while an external device controls a system wash. With the AutoClean Accessory, the Recycler controls a system wash and internally coordinates the Recycle Valve (V1) and Wash Valve (V2) positions. The REMOTE OVERRIDE is not necessary when washing the system using the AutoClean Accessory.

MANUAL MODE

In the MANUAL mode, the Recycle Valve (V1) position is controlled manually from the front panel keypad. This mode is often used during initial system equilibration. When in the MANUAL mode, pressing the UP or DOWN key will change the Recycle Valve (V1) position. To exit the MANUAL mode, press either the MODE or the ENTER key. The control module then enters the AUTO mode and the Recycle Valve (V1) position is controlled by the active METHOD. If the MANUAL mode is re-entered, the Recycle Valve (V1) returns to the position it was in when the MANUAL mode was last exited.

If the AutoClean Accessory is installed, the MANUAL MODE provides control of both the Recycle Valve (V1) and the Wash Valve (V2). Always place the Recycle Valve (V1) in the WASTE position when the Wash Valve (V2) is in the WASH position to prevent contamination of the mobile phase with wash solvent. The software will remind the analyst to flush mobile phase through the system prior to changing the Recycle Valve (V1)

from WASTE to RECYCLE to avoid inadvertent contamination of the mobile phase.

REMOTE MODE

The REMOTE mode lets an external device control the Recycle Valve (V1) position. The Recycle Valve (V1) remains in the RECYCLE position until the external device sends a switch closure through the Override cable (available as an optional item) to terminals 2 and 3 on the Recycle Valve (V1) connector block. When the signal is sent, the valve position is set to Waste. When the external signal is removed, the valve switches back to the RECYCLE position. In the REMOTE mode all other functions are disabled.

If the AutoClean Accessory is installed, always place the Recycle Valve (V1) in the WASTE position when the Wash Valve (V2) is in the WASH position to prevent contamination of the mobile phase with wash solvent. The software will remind the analyst to flush mobile phase through the system prior to changing the Recycle Valve (V1) position from WASTE to RECYCLE to avoid inadvertent contamination of the mobile phase.

METHOD

Choices: 0 through 9

The Solvent Recycler stores 10 METHODS in nonvolatile memory. A METHOD is required for the Solvent Recycler to function in the AUTO Mode. A METHOD contains user-selectable parameters for recycling and washing (if the AutoClean accessory is installed).

DETECTOR OUTPUT VOLTAGE

Choices: 10 mV, 100 mV, 400 mV, 1 V, or 10 V

Choose the voltage which matches the detector output. The DETECTOR OUTPUT VOLTAGE is preset to 10mV for all METHODS.

The DETECTOR OUTPUT VOLTAGE also determines the full scale voltage for the Validation Output, except when the 10V range is selected, in which case the Validation Output is set to 2V full scale.

DETECTOR TYPE

Choices: + or ±

These symbols refer to the type of deviation from baseline (positive only or both positive and negative) that are considered a contaminant. Select + to divert only positive peaks to WASTE. Select ± to divert both positive and negative peaks to WASTE. If ± is selected, the THRESHOLD value will be symmetrical with respect to the zero point. DETECTOR TYPE is preset to + for all METHODS.

DISPLAY UNITS

Choices: Absorbance, %FS, or Volts

The DISPLAY UNITS selects the units used for the detector signal and the THRESHOLD values on the Solvent Recycler's LCD. By selecting Absorbance, the display will show absorbance units with the full scale input corresponding to 1.00AU. When %FS (% full scale) is selected, the display will show the detector signal and THRESHOLD as a percent of full scale. When Volts are selected, the display will show the detector signal voltage. DISPLAY UNIT choice will not affect Recycler function. DISPLAY UNITS is preset to %FS for all METHODS.

THRESHOLD VALUE

Choices: From 0.1 to 20% of the selected DETECTOR OUTPUT VOLTAGE. Units are dependent on DISPLAY UNITS selected - See table listed.

The THRESHOLD value is the value which, when exceeded, causes the Recycle Valve (V1) position to change to WASTE. Higher values reduce the Solvent Recycler sensitivity to contaminants and may jeopardize recycled mobile phase purity. Lower values increase the sensitivity to contaminants, but may cause the Solvent Recycler to react to spurious detector noise and drift, causing unnecessary amounts of mobile phase to be diverted to WASTE. The THRESHOLD value is preset to 1% for all METHODS.

Display Units	Detector Output	Maximum Threshold	Increment Value
SOLVENT RECYCLER RANGES			
%FS	All	20%	0.1%
AU	All	0.2AU	0.001AU
Volts	10mV	2mV	0.01mV
	100mV	20mV	0.1mV
	400mV	80mV	0.4mV
	1V	200mV	1mV
	10V	2.0V	10mV

VALVE DELAY

Choices: 0 to 99 seconds, in 1 second increments

The VALVE DELAY controls the amount of time the Recycle Valve remains in the WASTE position after the detector signal drops below the THRESHOLD value. The VALVE DELAY accounts for peak tailing as well as mobile phase transit time in the tubing between the detector and the Recycle Valve (V1). If the detector signal rises above the THRESHOLD before the VALVE DELAY elapses (e.g. a second peak elutes), the VALVE DELAY is reset to its original value and does not start counting until the detector signal again drops below the THRESHOLD value. The VALVE DELAY is preset to 60 seconds for all methods.

THE FOLLOWING TERMS ARE USED ONLY WHEN THE AUTOCLEAN ACCESSORY IS INSTALLED.

WASH DELAY TIME

Choices: 0 to 999 minutes, in 1-minute increments, 0 = off

The WASH DELAY TIME controls the amount of time the Wash Valve (V2) will be in the WASH position when an external device sends a switch closure to terminals 1 and 2 of the Wash Valve (V2) connector block. During the WASH DELAY TIME, the Recycle Valve (V1) is set to the WASTE position. The LCD displays the amount of WASH DELAY TIME remaining. When the WASH is complete, the system will proceed to the EQUILIBRATION cycle, if programmed in the controlling method. If equilibration is not programmed, the message "AUTOCLEAN COMPLETE! Any Key for MANUAL Mode" appears. At this time a signal will be sent to shut off the pump (via a cable connected from terminals 3 and 4 on the Wash Valve (V2) connector block) if this has been programmed into the controlling method. The WASH DELAY TIME is preset to 0 (off) for all METHODS.

If the ENTER key is pressed at any point during the wash, the WASH DELAY TIME will be terminated. If an EQUILIBRATION cycle has not been programmed into the method, the instrument will revert to the MANUAL Mode. If the EQUILIBRATION cycle has been programmed, the system will proceed to re-equilibrate with mobile phase.

EQUILIBRATION

Choices: 0 to 999 minutes, in 1-minute increments, 0 = off

The EQUILIBRATION cycle controls the amount of time the Wash Valve (V2) will be in the M. PHASE position sending mobile phase to the pump after a wash cycle. During equilibration, the Recycle Valve (V1) will divert mobile phase to WASTE. The EQUILIBRATION cycle will be initiated either after the WASH DELAY TIME elapses or when the WASH DELAY TIME is interrupted. When the equilibration time reaches zero, the Recycle Valve (V1) position changes to RECYCLE and the software will revert back to the original METHOD selected for control of the Recycle Valve (V1) position. If the method in use specifies a "PUMP OFF" event, the pump will be shut off at this time.

PUMP OFF

Choices: Leave On and Turn Off

The PUMP OFF signal can be used to turn off most HPLC pumps. The method selected must be programmed for "TURN OFF" and the appropriate cable connection to the pump must be established. The PUMP OFF occurs at the conclusion of an uninterrupted WASH DELAY TIME or after completion of the EQUILIBRATION cycle.

FIGURE 5 - MICROPROCESSOR PROGRAMMING FLOWCHART FOR THE SOLVENT RECYCLER

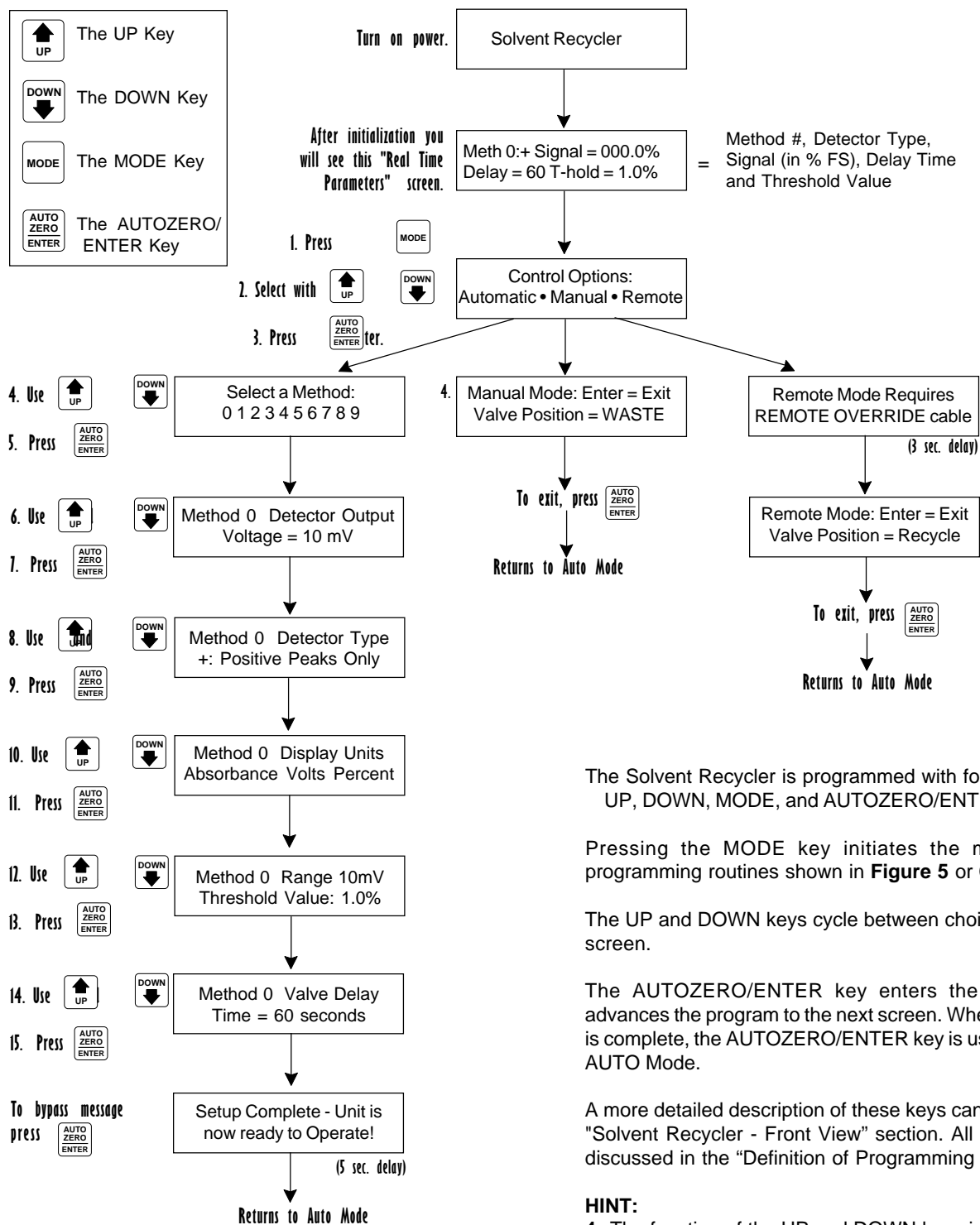

The Solvent Recycler is programmed with four keys: UP, DOWN, MODE, and AUTOZERO/ENTER.

Pressing the MODE key initiates the microprocessor programming routines shown in **Figure 5** or **6**.

The UP and DOWN keys cycle between choices on the LCD screen.

The AUTOZERO/ENTER key enters the selection and advances the program to the next screen. When programming is complete, the AUTOZERO/ENTER key is used to exit to the AUTO Mode.

A more detailed description of these keys can be found in the "Solvent Recycler - Front View" section. All other terms are discussed in the "Definition of Programming Terms" section.

HINT:

4. The function of the UP and DOWN keys in Step 4 differ in the Automatic and Manual Modes. In the Automatic Mode these keys select a method. In the Manual Mode these keys change the Recycle Valve (V1) or Wash Valve (V2) position.

FIGURE 6 - MICROPROCESSOR PROGRAMMING FLOWCHART FOR THE SOLVENT RECYCLER WITH AUTOCLEAN

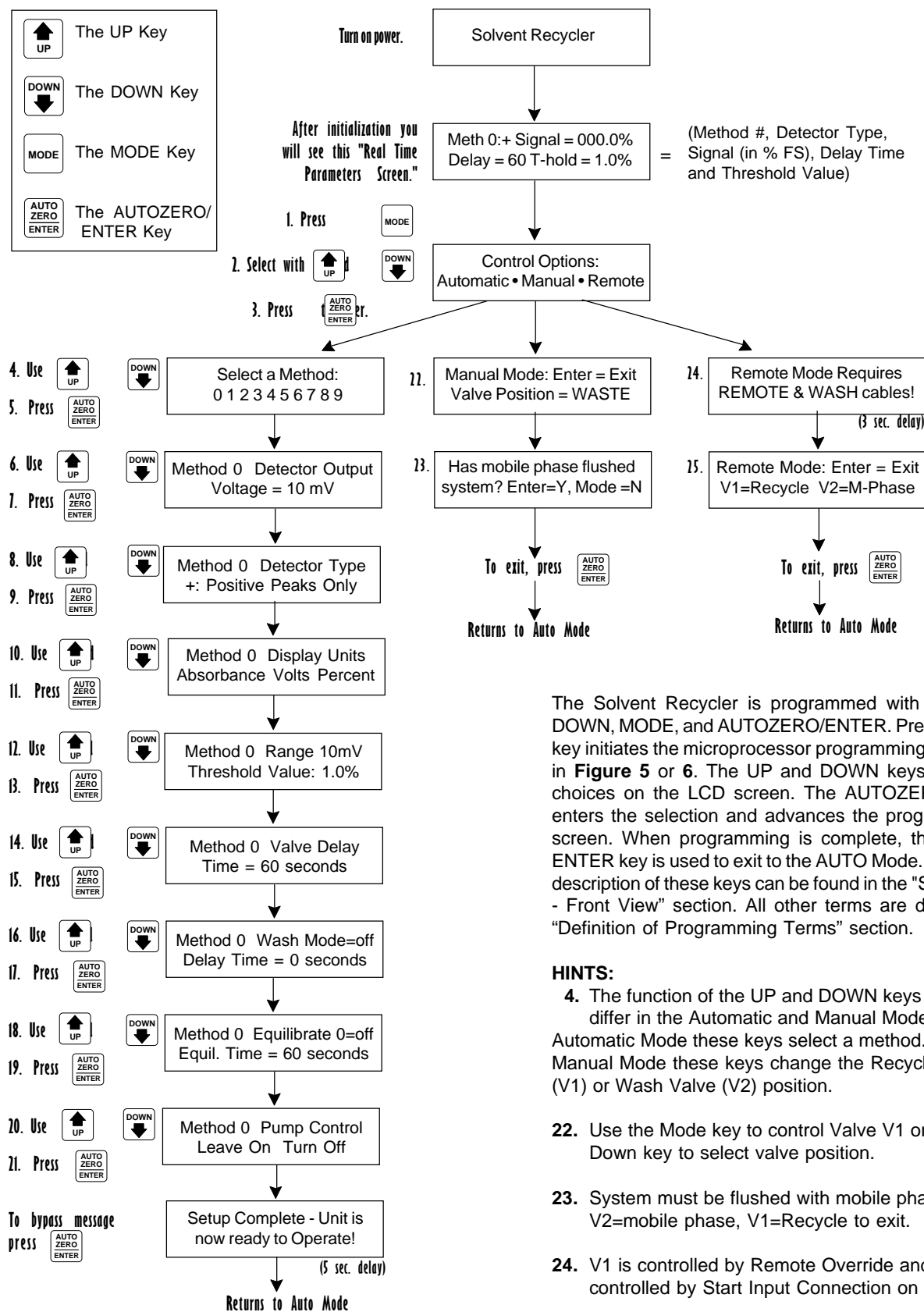

The Solvent Recycler is programmed with four keys: UP, DOWN, MODE, and AUTOZERO/ENTER. Pressing the MODE key initiates the microprocessor programming routines shown in **Figure 5** or **6**. The UP and DOWN keys cycle between choices on the LCD screen. The AUTOZERO/ENTER key enters the selection and advances the program to the next screen. When programming is complete, the AUTOZERO/ENTER key is used to exit to the AUTO Mode. A more detailed description of these keys can be found in the "Solvent Recycler - Front View" section. All other terms are discussed in the "Definition of Programming Terms" section.

HINTS:

- 4. The function of the UP and DOWN keys in Step 4 differ in the Automatic and Manual Modes. In the Automatic Mode these keys select a method. In the Manual Mode these keys change the Recycle Valve (V1) or Wash Valve (V2) position.
- 22. Use the Mode key to control Valve V1 or V2. Use Up or Down key to select valve position.
- 23. System must be flushed with mobile phase, i.e., V2=mobile phase, V1=Recycle to exit.
- 24. V1 is controlled by Remote Override and V2 is controlled by Start Input Connection on Rear Panel.

OPERATION

After initial installation the Solvent Recycler is ready to use. Complete familiarity with the previous sections, "Instrument Description" and "Definition of Programming Terms", is advised.

NOTE: When power is off, the Recycle Valve (V1) is in the RECYCLE position.

START UP

Turn on the Solvent Recycler by pushing the power button. After a brief initialization step and a microprocessor self-test, the Real Time Parameters screen will appear (see **Figure 5** or **6**). If a fault occurs, "Self Test Fault" will appear on the screen. Do not continue if this happens. Call Technical Service for assistance.

Refer to **Figures 5** and **6** as a guide for programming the Solvent Recycler. These Figures refer to Solvent Recycler programming without and with AutoClean, respectively.

PROGRAM THE INSTRUMENT

For an initial starting point, the default parameters of any METHOD in the AUTO Mode can be used. Alternatively, you can create your own METHOD. In any case, the DETECTOR OUTPUT VOLTAGE must be set. Refer to "Instrument Description - Front View" and the "Definition of Programming Terms" for making this selection.

ZERO THE SYSTEM

After the HPLC system is equilibrated, zero the detector, and then zero the Solvent Recycler from the front panel keypad. This will match the zero point of both instruments.

VERIFY RECYCLER FUNCTION

Inject a standard and check that the Recycle Valve (V1) position changes along with the valve status display LED's on the front panel. Also confirm that mobile phase is eluting from the appropriate tubing as the valve switches between RECYCLE and WASTE. Adjust the THRESHOLD value and VALVE DELAY so that all peaks are diverted to waste and only clean mobile phase is recycled.

You are now ready to begin your analysis.

See the troubleshooting flowchart in **Appendix B** if any problems occur during testing or use.

ADDITIONAL INFORMATION

SELECTION OF SOLVENT CONTAINERS

The mobile phase reservoir should be capped to prevent mobile phase contamination or evaporation. Helium sparging is recommended to keep the mobile phase degassed.

MOBILE PHASE SHELF LIFE

The Solvent Recycler decreases the amount of mobile phase needed for an assay and allows mobile phase to be used repeatedly, but it does not extend the mobile phase shelf life. We recommend that you establish a mobile phase shelf life to prevent chromatographic problems from aged mobile phase.

WASH SOLVENT SELECTION

Always choose a wash solvent that is miscible with the mobile phase and that will not cause mobile phase buffer precipitation. The primary reason to wash an HPLC system is to remove buffers and strongly retained contaminants from the HPLC column. In reversed-phase chromatography, prepare a wash solvent that includes water and a greater percentage of organic solvent than that used in the mobile phase. This will simultaneously remove strongly retained contaminants and buffer salts. Always test for buffer precipitation by first mixing the wash solvent and the mobile phase in a beaker. Any cloudiness indicates the wash solvent and mobile phase are not compatible.

RECYCLE VALVE (V1) TUBING AND FITTINGS

The Recycle Valve (V1) is pre-assembled with the correct tubing and fittings. The Recycle Valve (V1) outlet tubing has a larger I.D. (0.040", 1mm) than the inlet tubing (0.010", 0.25mm) to prevent excessive pressure on the Recycle Valve (V1). The valve is rated to 30psi. The accuracy of diverting contaminated mobile phase to waste is increased if the tubing from the detector to the Recycle Valve (V1) is as short as possible. When the Recycler is used with 0.040" tubing on both Recycle Valve outlet ports, the upper limit for solvent flow rate is 50mL/min. If flow rates greater than 50mL/min are needed, please call Technical Service. The Recycle Valve, when appropriately configured, can handle flow rates up to 350mL/min. For flow rates beyond 350mL/min, an optional Prep Valve is available. **Appendix C** lists Solvent Recycler replacement parts.

INSTRUMENT STORAGE AND CARE

If mobile phase containing buffer salts is used, flush the Recycle Valve (V1) thoroughly to remove these salts after each use. Crystallized buffer salts can damage the Recycle Valve and cause it to malfunction.

If a solvent spill occurs on or near the Solvent Recycler, wipe the area immediately. Some solvents can damage the appearance and function of the instrument.

APPENDIX A CABLE FORMATS

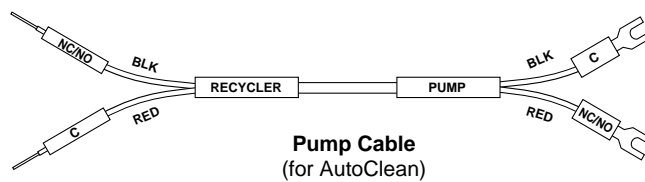
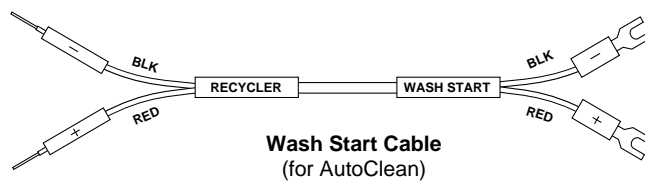
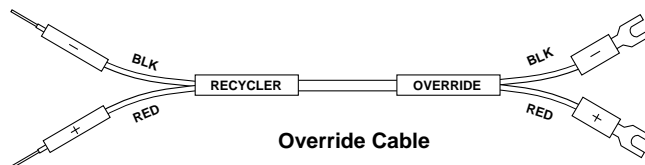
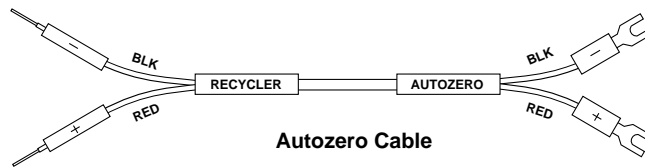
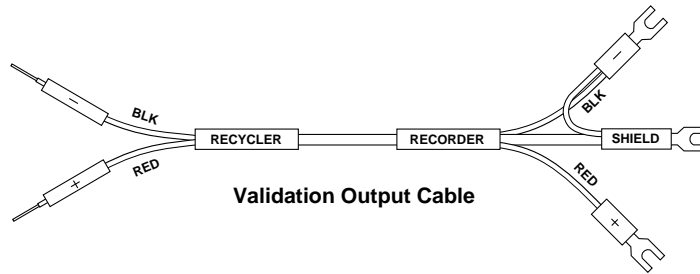
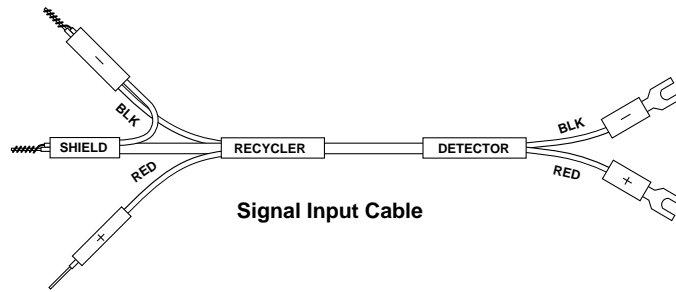

APPENDIX B TROUBLESHOOTING

MOST EFFECTIVE IF PERFORMED IN
SEQUENCE.

SYMPTOM	PROBLEM	SOLUTION
The front panel display does not respond.	The power cord is disconnected	Reconnect both ends of the power cord.
	The power source is defective.	Use another electrical outlet.
	The fuse is blown.	Replace the fuse.
	The Recycler is not turned on.	Turn on the Recycler.
No flow into Recycle Valve (V1).	The pump is off. Effluent not exiting the detector.	Turn on the pump. Troubleshoot the HPLC components and check all fittings for leaks.
No flow out of Recycle Valve (V1).	No flow into the valve.	As above.
The Recycle Valve (V1) flow is stuck in one position.	The valve is jammed.	Perform the following: Disconnect the WASTE and RECYCLE outlet tubing, compression screws, and ferrules. Check if the valve is operating properly by entering the MANUAL Mode and switching the valve between RECYCLE and WASTE. If the effluent is not being diverted correctly, try gently flushing the valve with warm water or call Technical Service. If the effluent is being diverted properly, check the WASTE and RECYCLE tubing for blockage.
	Outlet tubing is blocked.	Check for crimp. Check for precipitates. Replace tubing.
	The WASTE and RECYCLE tubing lengths are much different.	Measure the tubing and cut to similar lengths.
	The valve is damaged.	Call Technical Service for assistance.
The Wash Valve (V2) flow is stuck in one position.	Same problems as for the Recycle Valve.	Same solutions as for the Recycle Valve.
Detector Signal continuously reads 00.0% when a chromatogram is running.	The detector signal cable is not properly connected.	Review the installation instructions and reconnect.
	Detector output malfunction.	Check the detector output with voltmeter.
	Signal cable is defective.	Try another cable.
	Solvent Recycler is defective.	Call Technical Service.

continued on next page

APPENDIX B TROUBLESHOOTING (CONTINUED)

MOST EFFECTIVE IF PERFORMED IN
SEQUENCE.

SYMPTOM	PROBLEM	SOLUTION
Detector Signal never rises above 0.1% or 0.2%.	The DETECTOR OUTPUT VOLTAGE is set too high.	Match the DETECTOR OUTPUT VOLTAGE parameter on the Recycler to the actual DETECTOR OUTPUT VOLTAGE.
	Recycler is receiving detector signal attenuated by an integrator.	Connect detector directly to Recycler.
The Solvent Recycler will not zero.	The detector is not zeroed.	Zero the detector and re-zero the Solvent Recycler when the baseline is stable.
	The detector signal cable is not properly connected, or an inappropriate cable is in use.	To confirm function, disconnect Recycle Valve (V1) connector block from the rear panel, press the Autozero button. If unit zeros then it is functioning properly. Most likely the cable connection is incorrect. Review the Installation Section and reconnect. If the Solvent Recycler still will not zero repeat the Autozero again.
	If the Solvent Recycler still won't zero it could be defective.	Please call Technical Service for return authorization.
	Signal=OVRNG.	Voltage input selected is not matched to DETECTOR output.
	Control Module Malfunction.	Call Technical Service.
A "Self Test Fault" message appears on the front panel display.	The microprocessor is malfunctioning.	Call Technical Service.

APPENDIX C REPLACEMENT PARTS

Phenomenex Order No.	Replacement Part Description	Unit
AT0-2954	Teflon Tubing 1/16" x 1/32" (0.031") X 10'	ea
AQ0-3130	Tefzel Flangeless Nut, 1/16", ¼-28 threads, red	10/pk
AQ0-3131	Tefzel 1/16" Flangeless Ferrule, white	10/pk
AT0-2952	Teflon Tubing 1/16" x 0.010" x 10'	ea
AQ0-1673	Pre-assembled PEEK Union including 2 PEEK nuts and 2 double-sided ferrules	ea
AD0-1674	Single-Ended Signal Cable	ea
AD0-1676	Differential Signal Cable	ea
AD0-3132	Override Cable	ea
AV0-3136	Replacement Recycle Valve (V1) Assembly	ea
ADO-1677	Replacement Fuse, 5 x 20 mm, 0.2 Amp	ea
AV0-3133	Preparative Valve for Solvent Recycler	ea
AT0-2958	Teflon Tubing 1/8" x 0.1" x 10 ft.	ea
AQ0-3134	Delrin Flangeless Nut, 1/8", ¼-28 threads, green	10/pk
AQ0-3135	Tefzel 1/8" Flangeless Ferrule, green	10/pk
EH0-3123	AutoClean Accessory Kit	ea

APPENDIX D DIAGRAM OF THE SOLVENT RECYCLER CONTROL MODULE ELECTRONICS

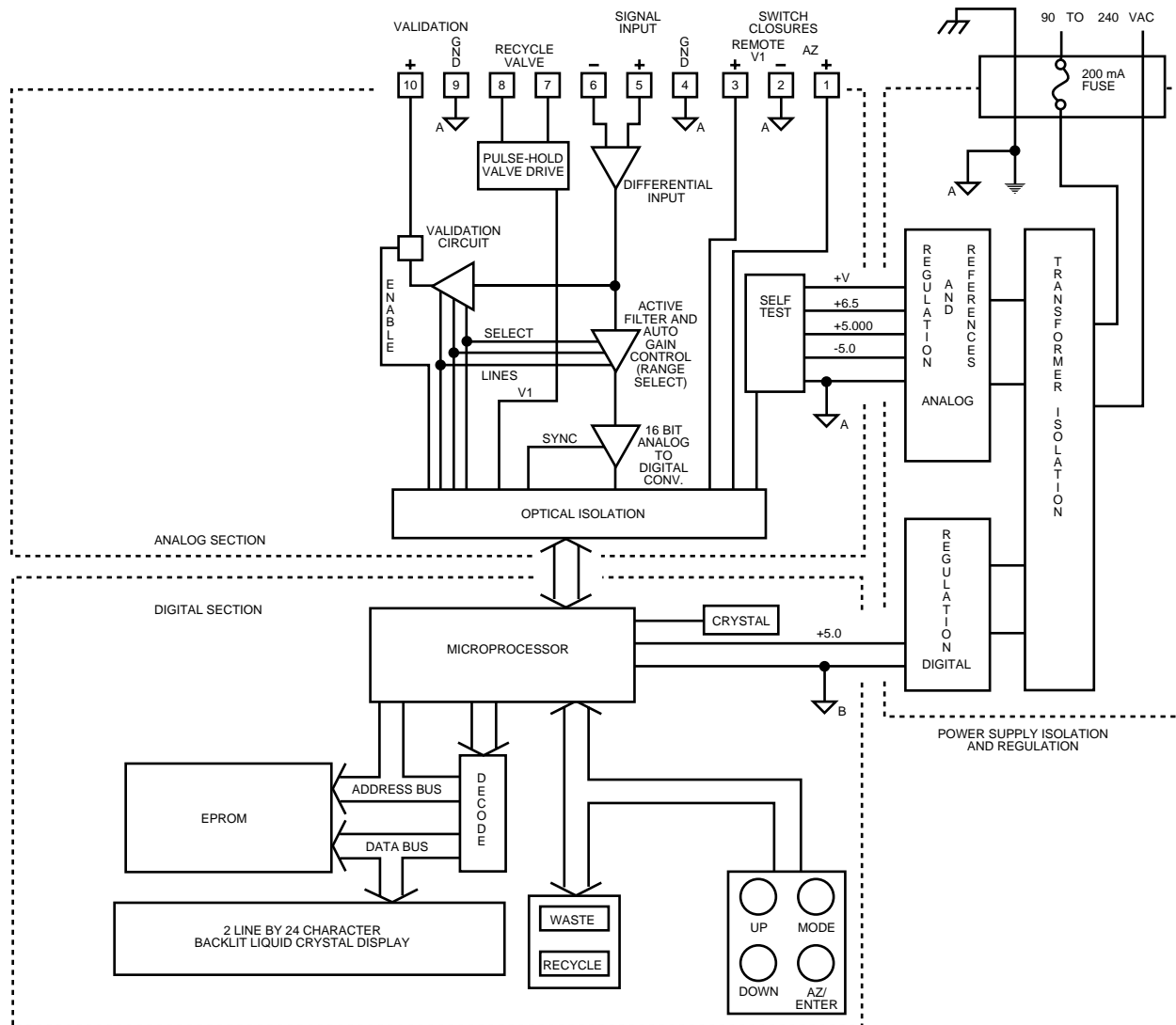

APPENDIX E

DIAGRAM OF THE SOLVENT RECYCLER CONTROL MODULE ELECTRONICS (WITH AUTOCLEAN)

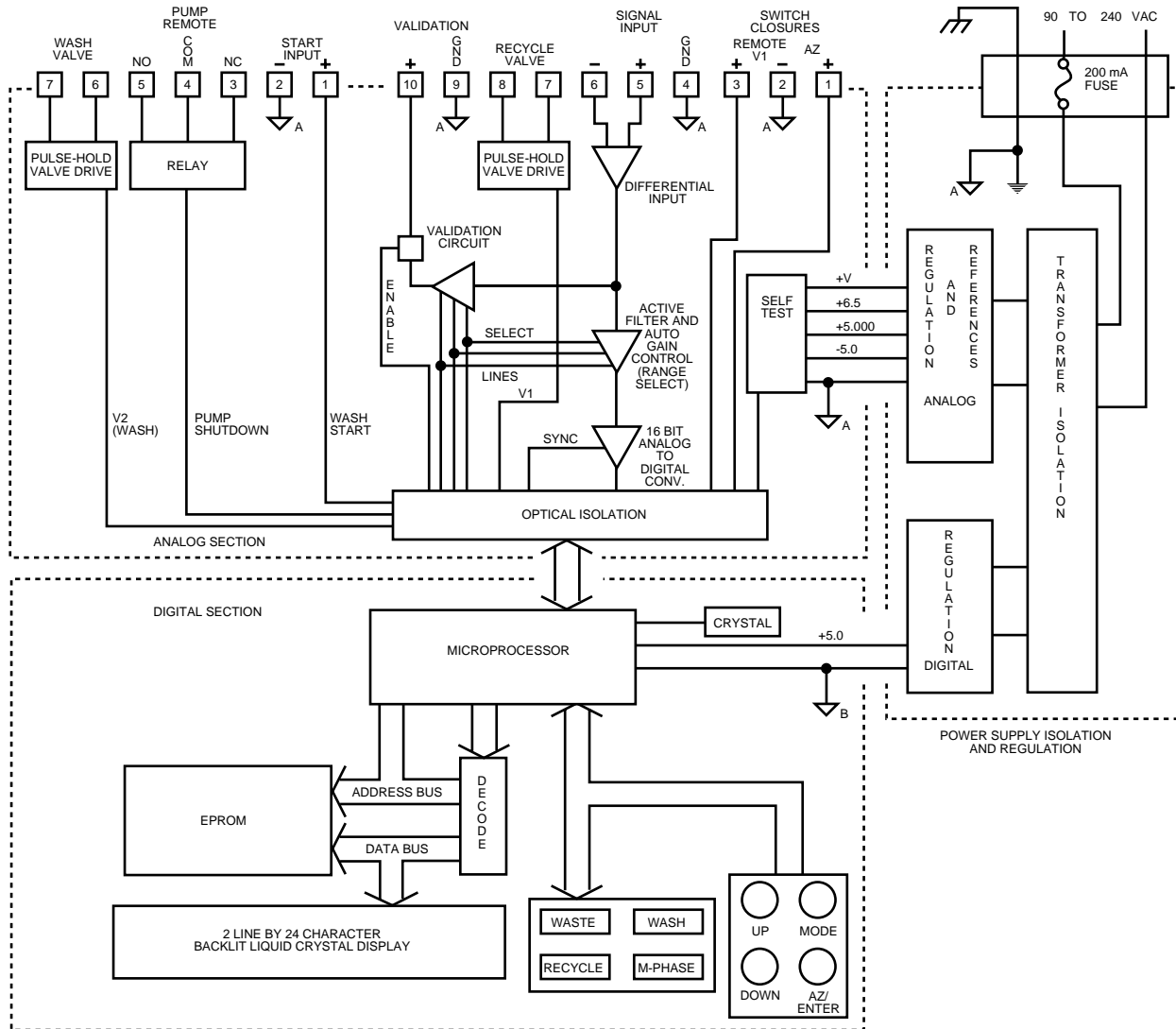

WARRANTY

Phenomenex warrants this product against defects in workmanship or material under normal use or service for three years, except the switching valve which is warranted for one year. All obligations or liabilities under this warranty are limited to repair or replacement, at Phenomenex's option, F.O.B. location of shipment of parts that are returned freight prepaid and which are accepted as being defective upon inspection by Phenomenex.

Components that are subject to normal wear and/or are scheduled for routine replacement within the warranty period, and/or parts, which are subjected to effects of corrosion or deterioration by chemical or other action, are excluded from the above warranty. Repair or replacement will not be made under warranty for malfunction due to inadequate facilities, operating conditions or utilities. The switching valve, which is warranted for one year, is also excluded from the three-year warranty.

Equipment and components may only be returned with Phenomenex's prior approval and must bear a Phenomenex Return Authorization Number.

Guarantees/Warranties on accessories and equipment included by/from other manufacturers are limited to the guarantees given on such equipment by the respective manufacturers. Any modifications made to equipment covered by this warranty without written permission from Phenomenex will void the warranty. Phenomenex reserves the right not to honor this warranty if the products are obviously mishandled by the user.

Phenomenex assumes no responsibility for consequential, economic or incidental damages of any nature or on-site reinstallation costs arising out of future alleged failure of any of its products or their accessories.

This warranty supersedes any and all previous warranties unless otherwise agreed upon at the time of sale, such as for customized equipment.

DAMAGED SHIPMENTS

The Interstate Commerce Commission has held that carriers are responsible for both concealed and visible damage occurring during transit. Unpack shipment promptly after receipt, as there may be concealed damage even though no evidence of it is apparent. If concealed damage is discovered, cease further unpacking of the unit involved and request immediate inspection by the local agent of the carrier and secure a written report of the findings to support a claim. This request must be made within 15 days of receipt, or the claim will not be honored by the carrier. Do not return damaged goods to the factory without first securing an inspection report and contacting Phenomenex or authorized dealer for a Return Authorization Number.

FILING OF CLAIMS

After a damage inspection report has been secured, Phenomenex will cooperate in replacing damaged goods and in handling of claims which have been initiated by either party.

For further inquiries, contact Phenomenex or
your local distributor:



	U.S.A.	PUERTO RICO	CANADA	UNITED KINGDOM	GERMANY	NEW ZEALAND	AUSTRALIA
MAIL:	2320 W. 205th St. Torrance, CA 90501-1456 U.S.A.	Oficina Correo 1559 Ave Americo Miranda San Juan, Puerto Rico 00921	2320 W. 205th St. Torrance, CA 90501-1456 U.S.A.	Queens Avenue, Hurdsfield Ind. Est., Macclesfield, Cheshire SK10 2BN, England	Zeppelinstr. 5 63741 Aschaffenburg Deutschland	P.O. Box 31-601 Milford Auckland New Zealand	P.O. Box 264 Pennant Hills NSW 1715 Australia
TEL:	(310) 212-0555	(800) 541-HPLC	(800) 543-3681	01625-501367	06021-58830-0	09-4780951	1800 553 929
FAX:	(310) 328-7768	(310) 328-7768	(310) 328-7768	01625-501796	06021-58830-11	09-4780952	1800 553 923

DISTRIBUTED BY: