



Agilent 1260 Infinity Binary Pump

User Manual



Agilent Technologies

Notices

© Agilent Technologies, Inc. 2005-2008, 2010-2013

No part of this manual may be reproduced in any form or by any means (including electronic storage and retrieval or translation into a foreign language) without prior agreement and written consent from Agilent Technologies, Inc. as governed by United States and international copyright laws.

Manual Part Number

G1312-90015 Rev. B

Edition

11/2013

Printed in Germany

Agilent Technologies
Hewlett-Packard-Strasse 8
76337 Waldbronn

This product may be used as a component of an in vitro diagnostic system if the system is registered with the appropriate authorities and complies with the relevant regulations. Otherwise, it is intended only for general laboratory use.

Warranty

The material contained in this document is provided “as is,” and is subject to being changed, without notice, in future editions. Further, to the maximum extent permitted by applicable law, Agilent disclaims all warranties, either express or implied, with regard to this manual and any information contained herein, including but not limited to the implied warranties of merchantability and fitness for a particular purpose. Agilent shall not be liable for errors or for incidental or consequential damages in connection with the furnishing, use, or performance of this document or of any information contained herein. Should Agilent and the user have a separate written agreement with warranty terms covering the material in this document that conflict with these terms, the warranty terms in the separate agreement shall control.

Technology Licenses

The hardware and/or software described in this document are furnished under a license and may be used or copied only in accordance with the terms of such license.

Restricted Rights Legend

If software is for use in the performance of a U.S. Government prime contract or subcontract, Software is delivered and licensed as “Commercial computer software” as defined in DFAR 252.227-7014 (June 1995), or as a “commercial item” as defined in FAR 2.101(a) or as “Restricted computer software” as defined in FAR 52.227-19 (June 1987) or any equivalent agency regulation or contract clause. Use, duplication or disclosure of Software is subject to Agilent Technologies’ standard commercial license terms, and non-DOD Departments and Agencies of the U.S. Government will

receive no greater than Restricted Rights as defined in FAR 52.227-19(c)(1-2) (June 1987). U.S. Government users will receive no greater than Limited Rights as defined in FAR 52.227-14 (June 1987) or DFAR 252.227-7015 (b)(2) (November 1995), as applicable in any technical data.

Safety Notices

CAUTION

A **CAUTION** notice denotes a hazard. It calls attention to an operating procedure, practice, or the like that, if not correctly performed or adhered to, could result in damage to the product or loss of important data. Do not proceed beyond a **CAUTION** notice until the indicated conditions are fully understood and met.

WARNING

A **WARNING** notice denotes a hazard. It calls attention to an operating procedure, practice, or the like that, if not correctly performed or adhered to, could result in personal injury or death. Do not proceed beyond a **WARNING** notice until the indicated conditions are fully understood and met.

In This Guide...

This manual covers the Agilent 1260 Infinity Binary Pump (G1312B).

1 Introduction to the Binary Pump

This chapter gives an introduction to the module and an instrument overview.

2 Site Requirements and Specifications

This chapter provides information about site requirements and specifications for the binary pump.

3 Installing the Pump

This chapter gives information about the preferred stack setup for your system and the installation of your binary pump.

4 Using the Pump

This chapter explains the operational parameters of the binary pump.

5 Optimizing Performance

This chapter gives information on how to optimize the performance of the Binary Pump under special operational conditions.

6 Troubleshooting and Diagnostics

Overview of the troubleshooting and diagnostic features.

7 Error Information

This chapter describes the meaning of error messages, and provides information on probable causes and suggested actions how to recover from error conditions.

8 Test Functions and Calibration

This chapter explains all test functions that are available for the binary pump.

9 Diagnostic Signals

This chapter explains all diagnostic signals of the binary pump.

10 Maintenance

This chapter describes the maintenance of the module.

11 Parts and Materials for Maintenance

This chapter lists all parts and tools that are required for maintenance.

12 Identifying Cables

This chapter provides information on cables used with the Agilent 1200 Infinity Series modules.

13 Hardware Information

This chapter provides detailed technical information about your binary pump.

14 Appendix

This appendix provides general safety and environmental information.

Contents

1	Introduction to the Binary Pump	9
	Instrument and Operation	10
	Overview of the Hydraulic Path	13
	Leak and Waste Handling	18
2	Site Requirements and Specifications	21
	Site Requirements	22
	Physical Specifications	25
	Performance Specifications	26
3	Installing the Pump	29
	Unpacking the Binary Pump	30
	Optimizing the Stack Configuration	33
	Installation Information on Leak and Waste Handling	41
	Installing the Binary Pump	45
	Flow Connections with Solvent Selection Valve	48
	Flow Connections without Solvent Selection Valve	51
	Priming the System	54
4	Using the Pump	59
	Leak and Waste Handling	60
	Hints for Successful Use of the Binary Pump	61
	Setting up the Pump with the G4208A Instant Pilot	62
	Setting up the Agilent 1260 Infinity Binary Pump G1312B with the Instrument Control Interface	63
	Solvent Information	69
	Algae Growth in HPLC Systems	74
	Prevent Blocking of Solvent Filters	76

5	Optimizing Performance	79
	When to Use a Vacuum Degasser	80
	When to Use the Active Seal Wash Option	81
	When to Use Alternative Seals	82
	When to Use the Low Volume Mixer	83
	When to Remove Damper and Mixer	84
	How to Optimize the Compressibility Compensation Setting	87
6	Troubleshooting and Diagnostics	91
	Overview of the Module's Indicators and Test Functions	92
	Status Indicators	94
	User Interfaces	96
	Agilent Lab Advisor Software	97
7	Error Information	99
	What Are Error Messages	101
	General Error Messages	102
	Module Error Messages	109
8	Test Functions and Calibration	125
	(System) Pressure Test	126
	Valve Test	131
	Binary Pump Solvent Compressibility Calibration	133
	Pump Elasticity Calibration	135
	Leak Rate Test	137
9	Diagnostic Signals	143
	Analog Pressure Output	144
	Diagnostic Signals in Chromatographic Data Systems	145

10 Maintenance 147

- Introduction to Maintenance and Repair 148
- Warnings and Cautions 149
- Cleaning the Module 151
- Overview of Maintenance and Simple Repairs 152
- Maintenance Procedures 153
- Exchanging the Purge Valve Frit or the Purge Valve 154
- Removing the Pump Head Assembly 157
- Maintenance of a Pump Head without Seal Wash 159
- Maintenance of a Pump Head with Seal Wash 163
- Reinstalling the Pump Head Assembly 167
- Seal Wear-in Procedure 169
- Exchanging the Active Inlet Valve (AIV) or its Cartridge 170
- Exchanging the Outlet Valve 173
- Installation of the Solvent Selection Valve Upgrade Kit 175
- Exchanging the Solvent Selection Valve 177
- Exchanging the Optional Interface Board 180
- Replacing Module Firmware 181

11 Parts and Materials for Maintenance 183

- Hydraulic Path with Solvent Selection Valve 184
- Hydraulic Path without Solvent Selection Valve 186
- Pump Head Assembly Without Seal Wash 188
- Pump Head Assembly with Seal Wash Option 190
- Outlet Valve 192
- Purge Valve Assembly 193
- Active Inlet Valve Assembly 194
- HPLC Starter Kit G4201-68707 195
- HPLC Starter Kit G4202-68707 195
- HPLC System Tool Kit 196
- Bottle Head Assembly 197
- Solvent Cabinet 198

12 Identifying Cables 201

- Overview 202
- Analog cables 204
- Remote Cables 206
- BCD Cables 209
- CAN/LAN Cables 211
- External Contact Cables 212
- RS-232 Cable Kit 213
- Agilent 1200 Module to Printer 214

13 Hardware Information 215

- Firmware Description 216
- Electrical Connections 219
- Interfaces 221
- Setting the 8-bit Configuration Switch (without On-board) LAN 228
- Optional Interface Boards 232
- The Solvent Selection Valve (SSV) 236
- Early Maintenance Feedback 237
- Instrument Layout 238

14 Appendix 239

- General Safety Information 240
- The Waste Electrical and Electronic Equipment Directive 243
- Lithium Batteries Information 244
- Radio Interference 245
- Sound Emission 246
- Agilent Technologies on the Internet 247



1 Introduction to the Binary Pump

Instrument and Operation	10
Introduction to the Pump	10
Principle of Operation	11
Overview of the Hydraulic Path	13
Leak and Waste Handling	18

This chapter gives an introduction to the module and an instrument overview.



Instrument and Operation

Introduction to the Pump

The binary pump comprises two identical pumps integrated into one housing. Binary gradients are created by high-pressure mixing. An optional degasser is available for applications that require best flow stability, especially at low flow rates, for maximum detector sensitivity. Pulse damper and mixer can be bypassed for low flowrate applications or whenever a minimal transient volume is desirable. Typical applications are high throughput methods with fast gradients on high resolution 2.1 mm columns. The pump is capable of delivering flow in the range of 0.1 – 5 mL/min against up to 600 bar. A solvent selection valve (optional) allows to form binary mixtures (isocratic or gradient) from one of two solvents per channel. Active seal wash (optional) is available for use with concentrated buffer solutions.

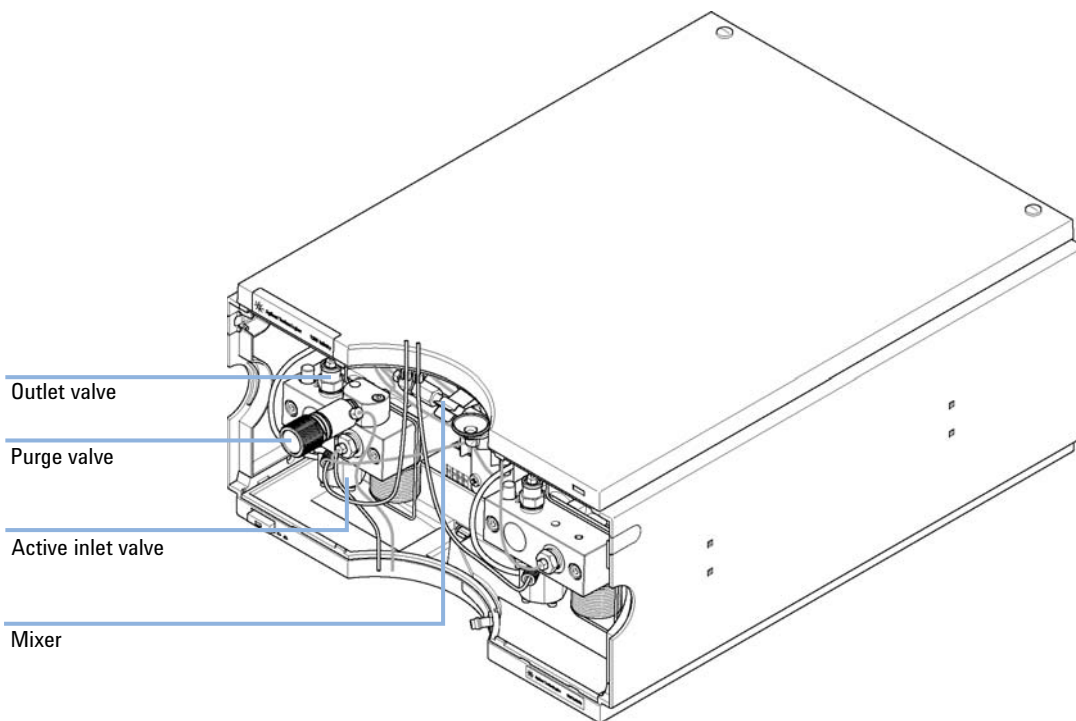

Figure 1 Overview of the binary pump

Principle of Operation

The binary pump is based on a two-channel, dual-piston in-series design which comprises all essential functions that a solvent delivery system has to fulfill. Metering of solvent and delivery to the high-pressure side are performed by two pump assemblies which can generate pressure up to 600 bar.

Each channel comprises a pump assembly including pump drive, pump head, active inlet valve with replaceable cartridge, and outlet valve. The two channels are fed into a low-volume mixing chamber which is connected via a restriction capillary coil to a damping unit and a mixer. A pressure sensor monitors the pump pressure. A purge valve with integrated PTFE frit is fitted to the pump outlet for convenient priming of the pumping system.

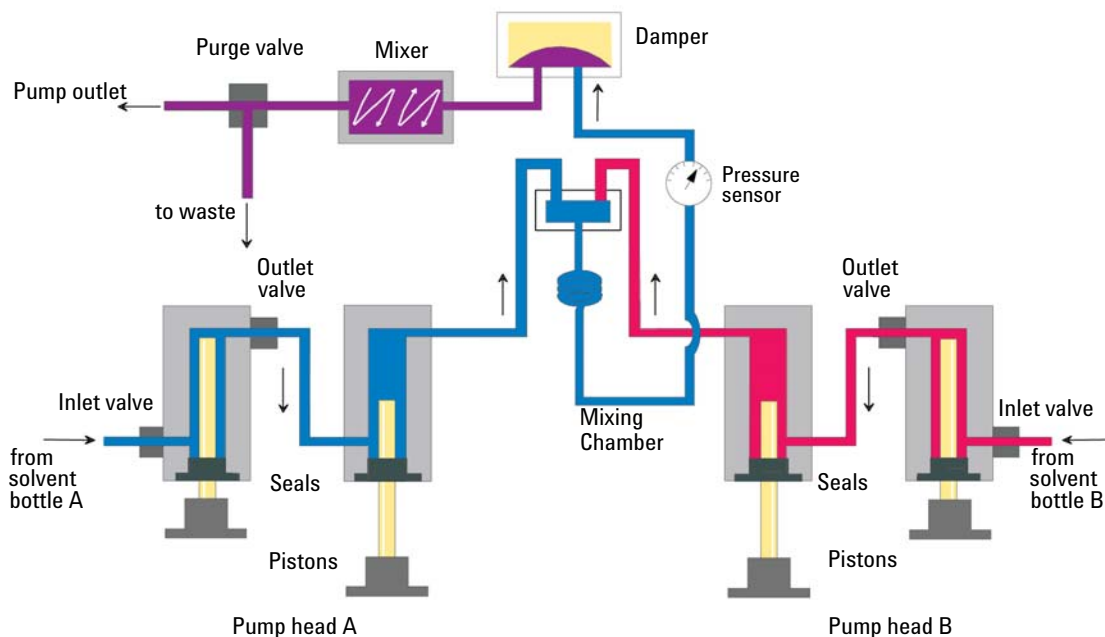

Figure 2 The Hydraulic Path of the Binary Pump with Damper and Mixer

1 Introduction to the Binary Pump Instrument and Operation

Damper and mixer can be bypassed for lowest delay volume of the binary pump. This configuration is recommended for low flow rate applications with steep gradients, see the Agilent 1260 Infinity Binary LC System Manual.

Figure 3 on page 12 illustrates the flow path in low delay volume mode. For instructions on how to change between the two configurations, see “Convert the Binary Pump to Low Delay Volume Mode” on page 85.

NOTE

Bypassing the mixer while the damper remains in line is not a supported configuration and may lead to undesired behavior of the binary pump.

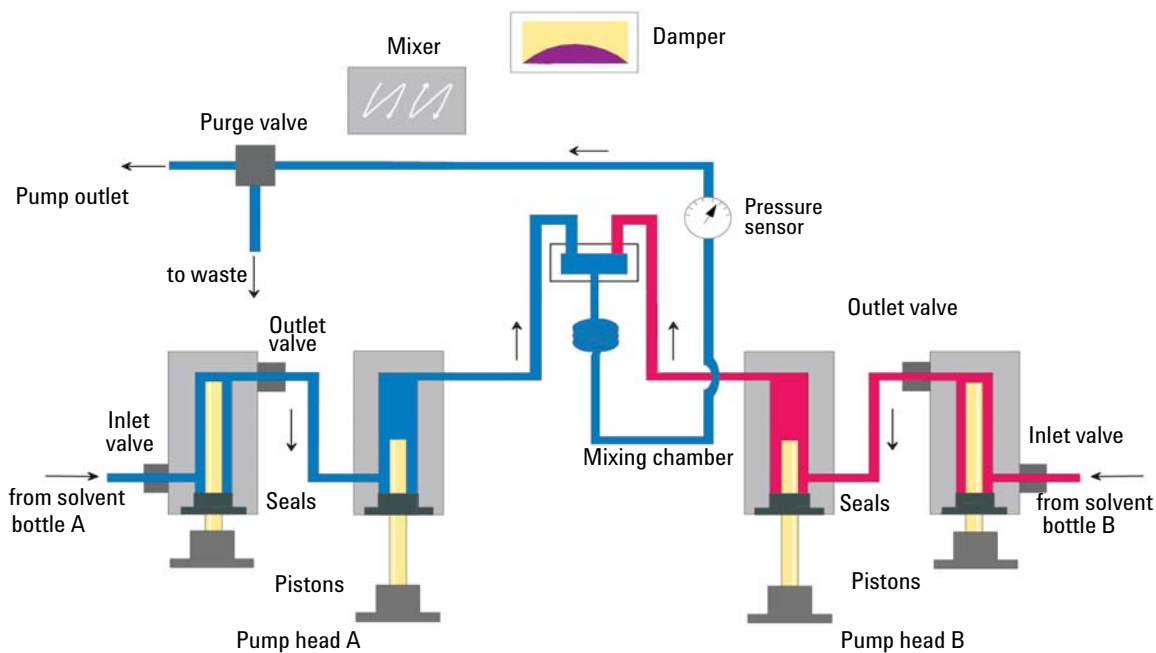

Figure 3 The Hydraulic Path of the Binary Pump with Bypassed Damper and Mixer

For pump specifications, see “Performance Specifications” on page 26.

Overview of the Hydraulic Path

The solvent from the bottle in the solvent cabinet enters the pump through an active inlet valve. Each side of the binary pump comprises two substantially identical pump units. Both pump units comprise a ball-screw drive and a pump head with two sapphire pistons for reciprocating movement.

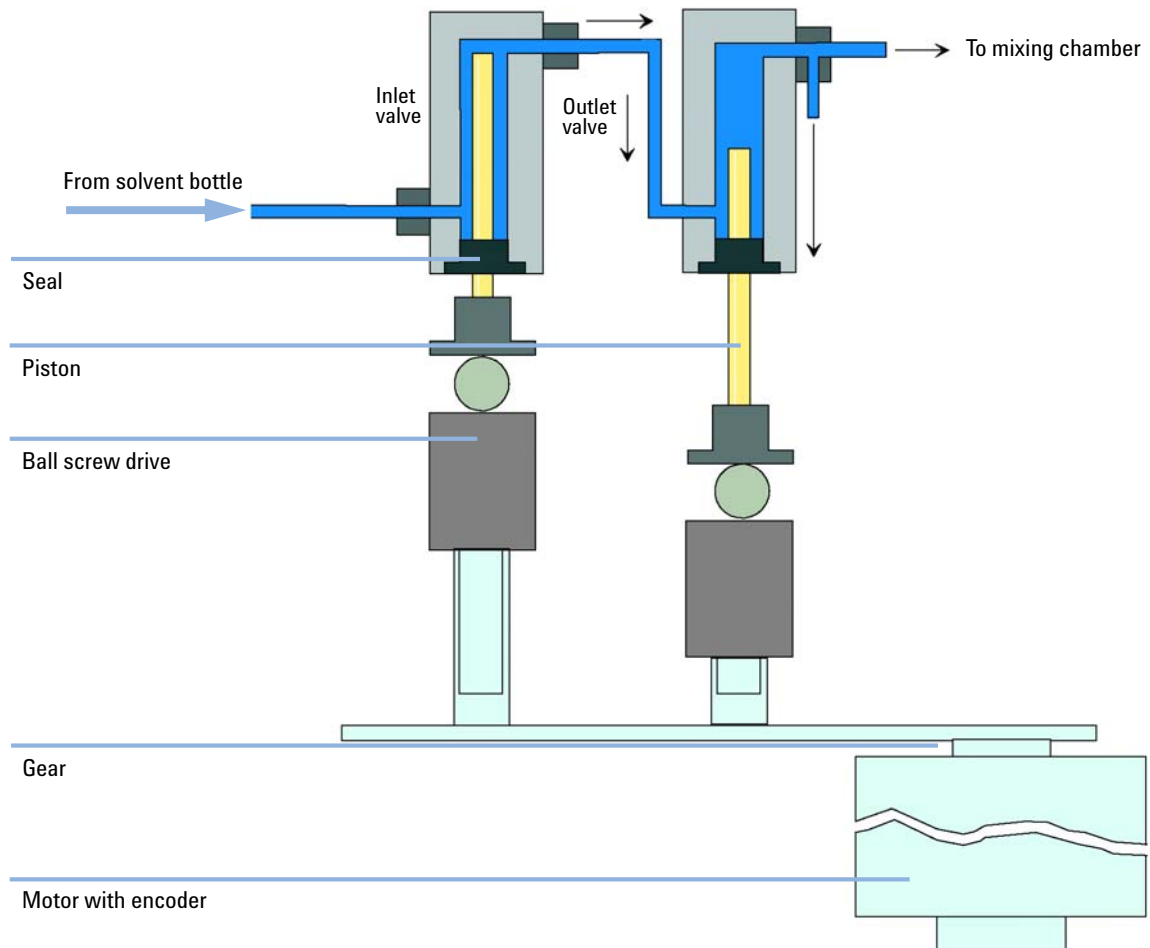

Figure 4 Pump head

A servo-controlled variable reluctance motor drives the two ball-screw drives in opposite directions. The gears for the ball-screw drives have different circumferences (ratio 2:1) allowing the first piston to move at double the speed of the second piston. The solvent enters the pump heads close to the bottom limit and leaves it at its top. The outer diameter of the piston is smaller than the inner diameter of the pump-head chamber allowing the solvent to fill the gap in between. The first piston has a stroke volume in the range of 20 μL to 100 μL depending on the flow rate. The microprocessor controls all flow rates in a range of 1 $\mu\text{L}/\text{min}$ to 5 mL/min . The inlet of the first pumping unit is connected to the active inlet valve which is processor-controlled opened or closed allowing solvent to be drawn into the first pump unit.

The outlet of the first pump chamber is connected by a 500 μL absorber capillary to the second pump chamber. The outlets of the second chambers of both pump channels joined via a small mixing chamber. A coiled restriction capillary connects the mixing chamber via a pressure pulse damper, a mixer and a pressure sensor to the purge valve assembly. The outlet of the purge valve assembly is then connected to the attached chromatographic system.

When turned on, the pump runs through an initialization procedure to determine the upper dead center of the first piston of both pump channels. The first piston moves slowly upwards to the mechanical stop of the pump head and from there it moves back a predetermined path length. The controller stores this piston position in memory. After this initialization the pump starts operation with the set parameters for the two pump channels.

The active inlet valve is opened and the down moving piston draws solvent into the first pump head. At the same time the second piston is moving upwards delivering into the system. After a controller defined stroke length (depending on the flow rate) the drive motors are stopped and the active inlet valve is closed. The motor direction is reversed and moves the first piston up until it reaches the stored upper limit and at the same time moving the second piston downwards.

Then the sequence starts again moving the pistons up and down between the two limits. During the delivery stroke of the first piston the solvent in the pump head is pressed through the outlet valve into the second pumping unit. The second piston draws in half of the volume displaced by the first piston and the remaining half volume is directly delivered into the system. During the drawing stroke of the first piston, the second piston delivers the drawn volume into the system.

For pump specifications, see “[Performance Specifications](#)” on page 26.

What is Pump Elasticity Compensation?

The flow path of the pump consists of pump chambers, sapphire pistons, polymer seals, stainless steel tubing of different dimension, pressure sensor, and so forth. All of these parts deform when pressurized. The sum of this deformation is called pump elasticity.

Let us look at a practical example: Piston 1 draws solvent at ambient pressure. The movement direction is reversed and the piston 1 now compresses the solvent until the operating pressure of the HPLC system is reached. The outlet valve opens, and solvent is pumped by piston 1 into pump chamber 2. Due to two factors, the solvent volume that is delivered into the system at high pressure is smaller than it is supposed to be:

- 1 The solvent is compressible
- 2 The pump has a certain elasticity which causes its internal volume to increase with pressure.

In order to compensate for these two influences, their contributions must be known. An elasticity calibration allows separating pump properties from solvent properties and therefore allows transferring solvent properties, which have been obtained from one pump to another pump with different elasticity.

Elasticity calibration is done with a solvent, which properties (compressibility, thermal expansion) are well-known and documented: pure water. When pumping water and using its property data for controlling the pump, any deviations from the theoretical pressure profile during solvent recompression are caused by the elasticity of the pump.

The *Pump Elasticity Calibration* calculates correction factors to compensate for the individual elasticity of the pump that is being calibrated. The elasticity is different for every pump and may change with the replacement of parts in the flow path, e.g. pump seals.

All binary pumps are elasticity calibrated at the factory and require recalibration only after preventive maintenance or major repairs to the flow path. Replacement of capillaries or PTFE frits are not considered as a major repair.

CAUTION

Incorrect pump elasticity calibration.

Solvent compressibility calibrations acquired with a miscalibrated pump will work, but they are not transferable to other pumps. A correct pump elasticity calibration is an essential prerequisite for successful solvent compressibility calibrations.

→ Calibrate the pump elasticity correctly.

What is Solvent Compressibility Compensation?

Although the compressibility of liquids is orders of magnitude lower than the compressibility of gases, without correction a noticeable volume error would be seen if typical chromatographic solvents are compressed to operating pressures as high as 600 bar. In addition, the compressibility depends on pressure, temperature and the amount of dissolved gas. In order to minimize the influence of the latter, the use of a vacuum degasser is mandatory for a high flow and composition precision. Unfortunately, the influence of the temperature on compressibility is non-linear and cannot be calculated.

The Agilent 1260 Infinity Binary Pump features a multi point compressibility calibration. The compressibility of a solvent is determined at different pressures from 0 – 600 bar and stored in an XML file. This file can be distributed to other pumps because the solvent compressibility is independent from the pump.

The binary pump and ChemStation come with predetermined solvent compressibility data for the most common HPLC solvents like water, acetonitrile, methanol, etc. Users can calibrate their own solvent mixtures with the help of an easy to use calibration procedure in the Agilent Lab Advisor software.

Let us use the practical example from the last section once again to understand how compressibility compensation works:

Piston 1 draws solvent at ambient pressure. The movement direction is reversed and piston 1 now compresses the solvent until the operating pressure of the HPLC system is reached. The outlet valve opens, and solvent is pumped by piston 1 into pump chamber 2.

Without any compensation, the delivered volume at operating pressure would be too low. In addition, it would take a noticeable amount of time to recompress the solvent to operating pressure. During this time frame, no solvent would be delivered into the system and as a result a high pressure fluctuation (known as *pressure ripple*) would be observed.

When both solvent compressibility at the current operating pressure and pump elasticity are known, the pump can automatically correct for the missing volume by drawing the appropriate larger solvent volume at ambient pressure and speed up the piston during the recompression phase in the first pump chamber. As a result, the pump delivers the accurate volume with any (calibrated) solvent at any pressure at a greatly reduced pressure ripple. For applications that require lowest transition volume of the pump, damper and mixer can be bypassed.

For compatibility with older methods from G1312A Binary Pumps, the previous one- point compressibility compensation is available, too. However, since the compressibility is a non-linear function, one single compressibility value per solvent will only give good results at one particular pressure

How Does Variable Stroke Volume Work?

The smaller the solvent volume in the pump chamber is, the faster it can be recompressed to operating pressure. The binary pump allows to manually or automatically adjust the pump stroke volume of the first piston in the range of 20 – 100 μL . Due to the compression of the solvent volume in the first pump chamber, each piston stroke of the pump will generate a small pressure pulsation, influencing the flow ripple of the pump. The amplitude of the pressure pulsation mainly depends on the stroke volume and the compressibility compensation for the solvent in use. Small stroke volumes generate less pressure pulsation than larger stroke volumes at the same flow rate. In addition, the frequency of the pressure pulsation will be higher. This will decrease the influence of flow pulsations on retention times.

In gradient mode, a smaller stroke volume results in less flow ripple and reduces the composition ripple.

The binary pump uses a processor-controlled ball screw system for driving its pistons. The normal stroke volume is optimized for the selected flow rate. Small flow rates use a small stroke volume while higher flow rates use a higher stroke volume.

The stroke volume for the pump is by default set to AUTO mode. This means that the stroke is optimized for the flow rate in use. A change to larger stroke volumes is possible but not recommended.

Leak and Waste Handling

The 1200 Infinity Series has been designed for safe leak and waste handling. It is important that all security concepts are understood and instructions are carefully followed.

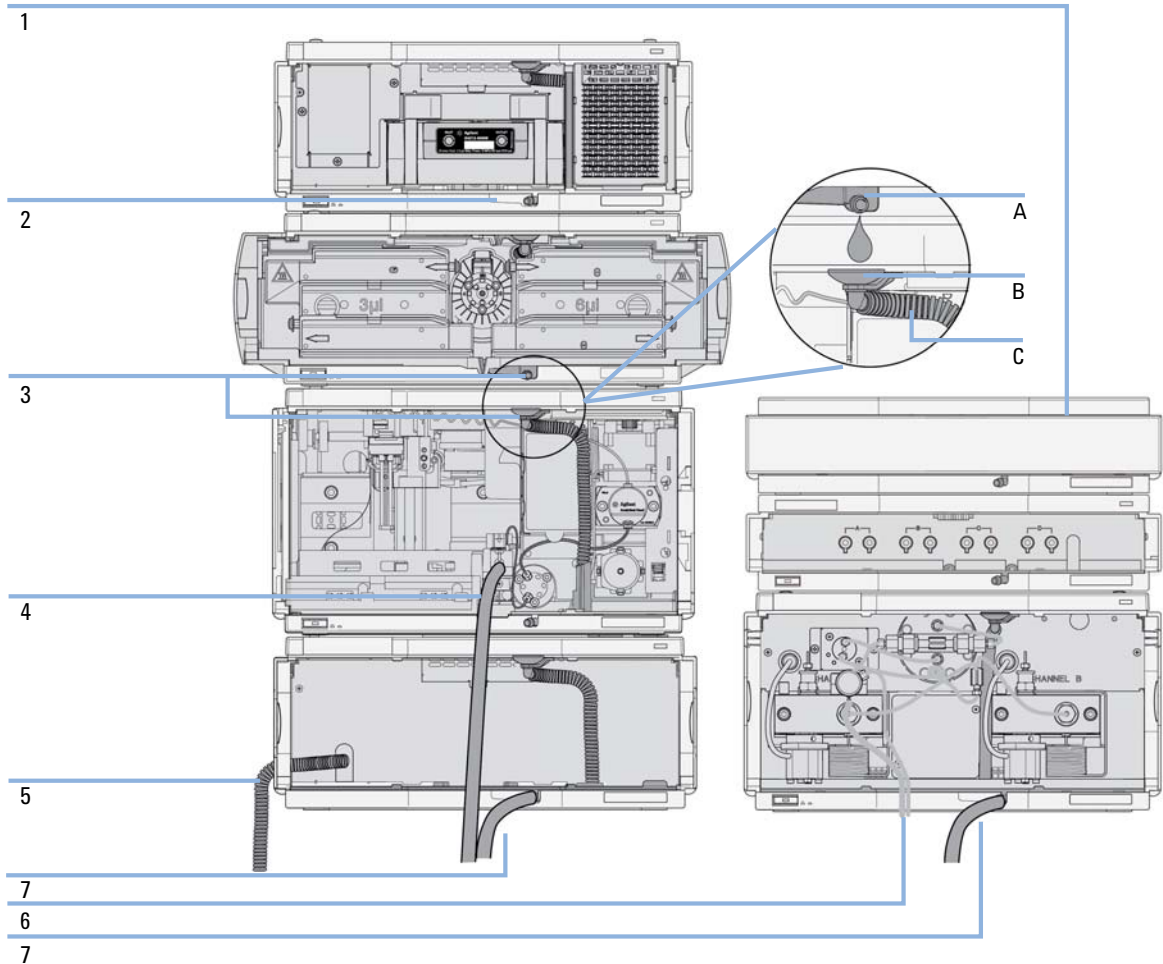

Figure 5 Leak and waste handling concept (overview - typical stack configuration as an example)

The solvent cabinet (1) is designed to store a maximum volume of 6 L solvent. The maximum volume for an individual bottle stored in the solvent cabinet should not exceed 2.5 L. For details, see the usage guideline for the Agilent 1200 Infinity Series Solvent Cabinets (a printed copy of the guideline has been shipped with the solvent cabinet, electronic copies are available on the Internet).

The leak pan (2) (individually designed in each module) guides solvents to the front of the module. The concept covers also leakages on internal parts (e.g. the detector's flow cell). The leak sensor in the leak pan stops the running system as soon as the leak detection level is reached.

The leak pan's outlet port (3, A) guides excessive overflow from one module to the next, as the solvent flows into the next module's leak funnel (3, B) and the connected corrugated waste tube (3, C). The corrugated waste tube guides the solvent to the next lower positioned module's leak tray and sensor.

The waste tube of the sampler's needle wash port (4) guides solvents to waste.

The condense drain outlet of the autosampler cooler (5) guides condensate to waste.

The waste tube of the purge valve (6) guides solvents to waste.

The waste tube connected to the leak pan outlet on each of the bottom instruments (7) guides the solvent to a suitable waste container.

1 Introduction to the Binary Pump

Leak and Waste Handling



2 Site Requirements and Specifications

Site Requirements	22
Physical Specifications	25
Performance Specifications	26

This chapter provides information about site requirements and specifications for the binary pump.



Site Requirements

A suitable environment is important to ensure optimal performance of the instrument.

Power Considerations

The module power supply has wide ranging capability. It accepts any line voltage in the range described in [Table 1](#) on page 25. Consequently there is no voltage selector in the rear of the module. There are also no externally accessible fuses, because automatic electronic fuses are implemented in the power supply.

WARNING

Hazard of electrical shock or damage of your instrumentation can result, if the devices are connected to a line voltage higher than specified.

→ Connect your instrument to the specified line voltage only.

WARNING

The module is partially energized when switched off, as long as the power cord is plugged in.

Repair work at the module can lead to personal injuries, e.g. electrical shock, when the cover is opened and the module is connected to power.

→ Always unplug the power cable before opening the cover.

→ Do not connect the power cable to the instrument while the covers are removed.

CAUTION

Inaccessible power plug.

In case of emergency it must be possible to disconnect the instrument from the power line at any time.

→ Make sure the power connector of the instrument can be easily reached and unplugged.

→ Provide sufficient space behind the power socket of the instrument to unplug the cable.

Power Cords

Different power cords are offered as options with the module. The female end of all power cords is identical. It plugs into the power-input socket at the rear. The male end of each power cord is different and designed to match the wall socket of a particular country or region.

WARNING

Absence of ground connection or use of unspecified power cord

The absence of ground connection or the use of unspecified power cord can lead to electric shock or short circuit.

- Never operate your instrumentation from a power outlet that has no ground connection.
 - Never use a power cord other than the Agilent Technologies power cord designed for your region.
-

WARNING

Use of unsupplied cables

Using cables not supplied by Agilent Technologies can lead to damage of the electronic components or personal injury.

- Never use cables other than the ones supplied by Agilent Technologies to ensure proper functionality and compliance with safety or EMC regulations.
-

WARNING

Unintended use of supplied power cords

Using power cords for unintended purposes can lead to personal injury or damage of electronic equipment.

- Never use the power cords that Agilent Technologies supplies with this instrument for any other equipment.
-

Bench Space

The module dimensions and weight (see [Table 1](#) on page 25) allow you to place the module on almost any desk or laboratory bench. It needs an additional 2.5 cm (1.0 inches) of space on either side and approximately 8 cm (3.1 inches) in the rear for air circulation and electric connections.

If the bench shall carry a complete HPLC system, make sure that the bench is designed to bear the weight of all modules.

The module should be operated in a horizontal position.

Condensation

CAUTION

Condensation within the module

Condensation will damage the system electronics.

- Do not store, ship or use your module under conditions where temperature fluctuations could cause condensation within the module.
 - If your module was shipped in cold weather, leave it in its box and allow it to warm slowly to room temperature to avoid condensation.
-

Physical Specifications

Table 1 Physical Specifications

Type	Specification	Comments
Weight	15.5 kg (34 lbs)	
Dimensions (height × width × depth)	180 x 345 x 435 mm (7 x 13.5 x 17 inches)	
Line voltage	100 – 240 VAC, ± 10 %	Wide-ranging capability
Line frequency	50 or 60 Hz, ± 5 %	
Power consumption	220 VA, 74 W / 253 BTU	Maximum
Ambient operating temperature	0–55 °C (32–131 °F)	
Ambient non-operating temperature	-40 – 70 °C (-40 – 158 °F)	
Humidity	< 95 % r.h. at 40 °C (104 °F)	Non-condensing
Operating altitude	Up to 2000 m (6562 ft)	
Non-operating altitude	Up to 4600 m (15091 ft)	For storing the module
Safety standards: IEC, CSA, UL	Installation category II, Pollution degree 2	For indoor use only.

Performance Specifications

Table 2 Performance Specifications of the Agilent 1260 Infinity Binary Pump (G1312B)

Type	Specification	Comments
Hydraulic system	Two dual piston in series pumps with servo-controlled variable stroke drive, power transmission by gears and ball screws, floating pistons	
Setable flow range	Set points 0.001 – 5 mL/min, in 0.001 mL/min increments	
Flow range	0.05 – 5.0 mL/min	
Flow precision	≤0.07 % RSD or ≤0.02 min SD, whatever is greater	based on retention time at constant room temperature
Flow accuracy	± 1 % or 10 µL/min, what ever is greater	pumping degassed H ₂ O at 10 MPa (100 bar)
Pressure operating range	Operating range 0 – 60 MPa (0 – 600 bar, 0 – 8700 psi) up to 5 mL/min	
Pressure pulsation	< 2 % amplitude (typically < 1.3 %), or < 0.3 MPa (3 bar), whatever is greater, at 1 mL/min isopropanol, at all pressures > 1 MPa (10 bar, 147 psi) <i>Low delay volume configuration:</i> < 5 % amplitude (typically < 2 %)	
Compressibility compensation	Pre-defined, based on mobile phase compressibility	
Recommended pH range	1.0 – 12.5, solvents with pH < 2.3 should not contain acids which attack stainless steel	
Gradient formation	High-pressure binary mixing	
Delay volume	<i>Standard delay volume configuration:</i> 600 – 800 µL, (includes 400 µL mixer), dependent on back pressure <i>Low delay volume configuration:</i> 120 µL	measured with water at 1 mL/min (water/caffeine tracer)

Table 2 Performance Specifications of the Agilent 1260 Infinity Binary Pump (G1312B)

Type	Specification	Comments
Composition range	settable range: 0 – 100 % recommended range: 1 – 99 % or 5 µL/min per channel, whatever is greater	
Composition precision	< 0.15 % RSD or < 0.04 min SD whatever is greater	at 0.2 and 1 mL/min; based on retention time at constant room temperature
Composition accuracy	± 0.35 % absolute, at 2 mL/min, at 10 MPa (100 bar)	(water/caffeine tracer)
Control	Agilent control software (e.g. ChemStation, EZChrom, OL, MassHunter)	
Local control	Agilent Instant Pilot	Revision B.02.00 or above
Analog output	For pressure monitoring, 1.33 mV/bar, one output	
Communications	Controller-area network (CAN), RS-232C, APG Remote: ready, start, stop and shut-down signals, LAN optional	
Safety and maintenance	Extensive support for troubleshooting and maintenance is provided by the Instant Pilot, Agilent Lab Advisor, and the Chromatography Data System. Safety-related features are leak detection, safe leak handling, leak output signal for shutdown of pumping system, and low voltages in major maintenance areas.	
GLP features	Early maintenance feedback (EMF) for continuous tracking of instrument usage in terms of seal wear and volume of pumped mobile phase with pre-defined and user settable limits and feedback messages. Electronic records of maintenance and errors	
Housing	All materials are recyclable	

NOTE

For use with flow rates below 500 µl/min or for use without damper and mixer a vacuum degasser is required.

All specification measurements are done with degassed solvents.

2 Site Requirements and Specifications

Performance Specifications



3 Installing the Pump

Unpacking the Binary Pump	30
Optimizing the Stack Configuration	33
Installation Information on Leak and Waste Handling	41
Installing the Binary Pump	45
Flow Connections with Solvent Selection Valve	48
Flow Connections without Solvent Selection Valve	51
Priming the System	54
Initial Priming	54
Regular Priming	56
Changing Solvents	57

This chapter gives information about the preferred stack setup for your system and the installation of your binary pump.



Unpacking the Binary Pump

Damaged Packaging

If the delivery packaging shows signs of external damage, please call your Agilent Technologies sales and service office immediately. Inform your service representative that the instrument may have been damaged during shipment.

CAUTION

"Defective on arrival" problems

If there are signs of damage, please do not attempt to install the module. Inspection by Agilent is required to evaluate if the instrument is in good condition or damaged.

- Notify your Agilent sales and service office about the damage.
 - An Agilent service representative will inspect the instrument at your site and initiate appropriate actions.
-

Delivery Checklist

Compare the delivery checklist with the contents of the shipping boxes to ensure completeness of the shipment. The contents lists is shown below. For parts identification check the illustrated parts breakdown in “[Parts and Materials for Maintenance](#)” on page 183. Please report missing or damaged parts to your local Agilent Technologies sales and service office.

p/n	Description
G1312B	Agilent 1260 Infinity Binary Pump optionally with active seal wash and/or solvent selection valve
G1311-60003 (2x)	Bottle-head assembly (OPTIONAL)
G1369C	Interface board (LAN) (OPTIONAL)
G1312-67500	Calibration capillary assembly
G1312-90303	Agilent 1260 Infinity Binary LC System User Guide not orderable
G4201-68707	HPLC Starter Kit incl. 0.17 mm i.d. cap (OPTIONAL)
G4202-68707	HPLC Starter Kit incl. 0.12 mm i.d. cap (OPTIONAL)
G4203-68708	HPLC System Tool Kit (OPTIONAL)
827975-902	Column: SB-C18, 4.6x50 mm, 1.8 µm, 600 bar (OPTIONAL)
959961-902	Column Eclipse Plus C18, 4.6 x 100 mm, 3.5 µm (OPTIONAL)
699975-302	Column Poroshell 120 EC-C18, 3.0 x 50 mm, 2.7 µm (OPTIONAL)
699975-902	Column Poroshell 120 EC-C18, 4.6 x 50 mm, 2.7 µm (OPTIONAL)
5067-4770	Solvent Cabinet Kit (OPTIONAL)
G4800-64500	Agilent 1200 Infinity Series User Documentation DVD (OPTIONAL) not orderable (OPTIONAL)
M8500A	Lab Advisor incl. license (OPTIONAL) Power cord

NOTE

Items identified as "optional" are additional accessories. They are not included in the standard scope of delivery.

NOTE

Items identified as "not orderable" can be downloaded from the Agilent website <http://www.agilent.com>.

3 Installing the Pump

Unpacking the Binary Pump

Accessory Kit

The Accessory Kit (G1311-68755) contains the following items:

p/n	Description
5062-2461	Waste tube, 5 m (reorder pack)
5063-6527	Tubing assembly, i.d. 6 mm, o.d. 9 mm, 1.2 m (to waste)
5181-1519	CAN cable, Agilent module to module, 1 m
G1329-87300	Capillary ST 0.17 mm x 900 mm S/S pump to thermostatted autosampler
G1312-87303	Capillary ST 0.17 mm x 400 mm S/S pump to injector
5042-9967	Tubing clip (set of 5 clips)

Optimizing the Stack Configuration

Agilent 1260 Infinity Binary LC in Standard Delay Volume Configuration

This configuration is typically used when using 4.6 mm and 3.0 mm i.d. columns. It is optimized for high flow rates and maximum sensitivity.

For a more detailed help on configuring your instrument, refer to the Agilent 1260 Infinity Binary LC System User Guide.

3 Installing the Pump

Optimizing the Stack Configuration

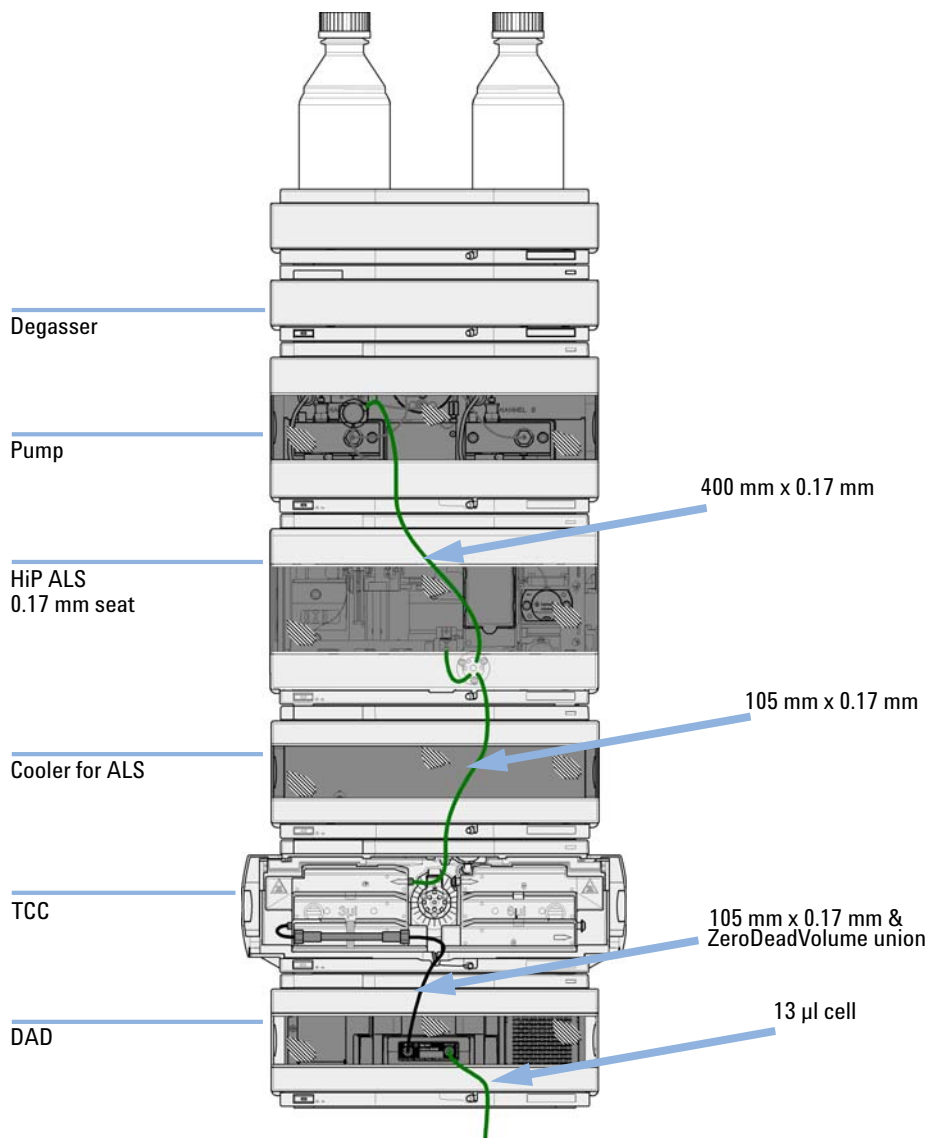

Figure 6 Agilent 1260 Infinity Binary LC in standard delay volume configuration for 4.6 mm and 3.0 mm i.d. columns

Agilent 1260 Infinity Binary LC in Medium Delay Volume Configuration

This setup is used for best signal to noise ratio using 2.1 mm and 3.0 mm columns.

For a more detailed help on configuring your instrument, refer to the Agilent 1260 Infinity Binary LC System User Guide.

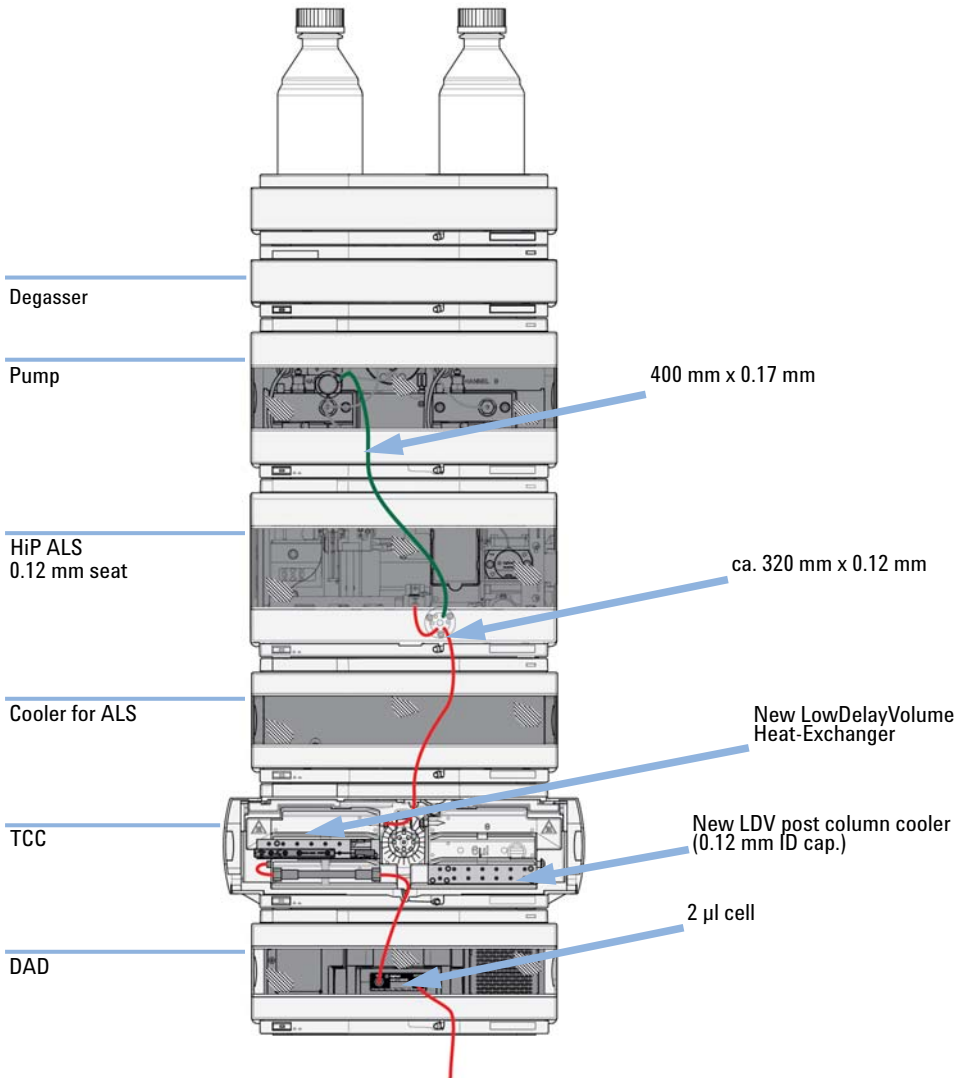

Figure 7 Agilent 1260 Infinity Binary LC in low delay volume configuration for 2.1 mm and 3.0 mm id columns

3 Installing the Pump

Optimizing the Stack Configuration

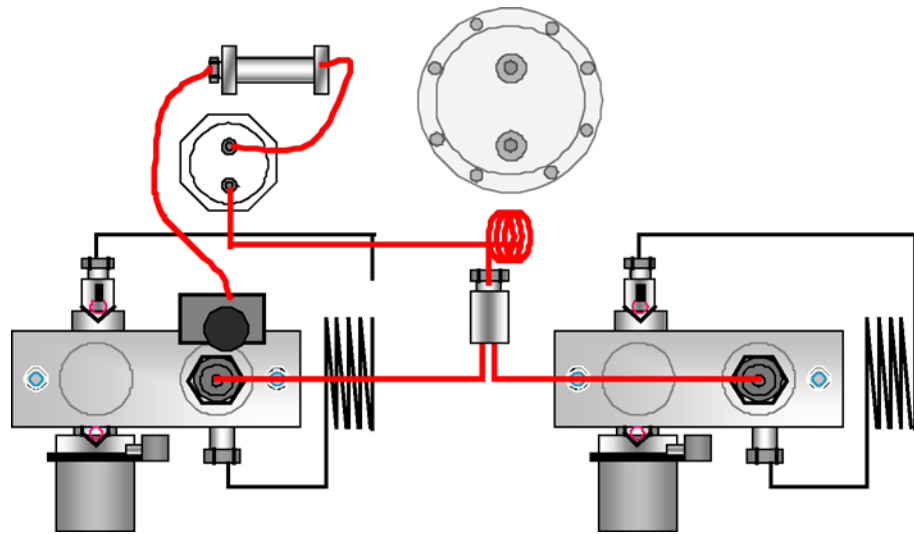

Figure 8 Binary pump in medium delay volume configuration

Agilent 1260 Infinity Binary LC in Low Delay Volume Configuration

In this configuration the LC is optimized for speed with the 2.1 mm columns.

For a more detailed help on configuring your instrument, refer to the Agilent 1260 Infinity Binary LC System User Guide.

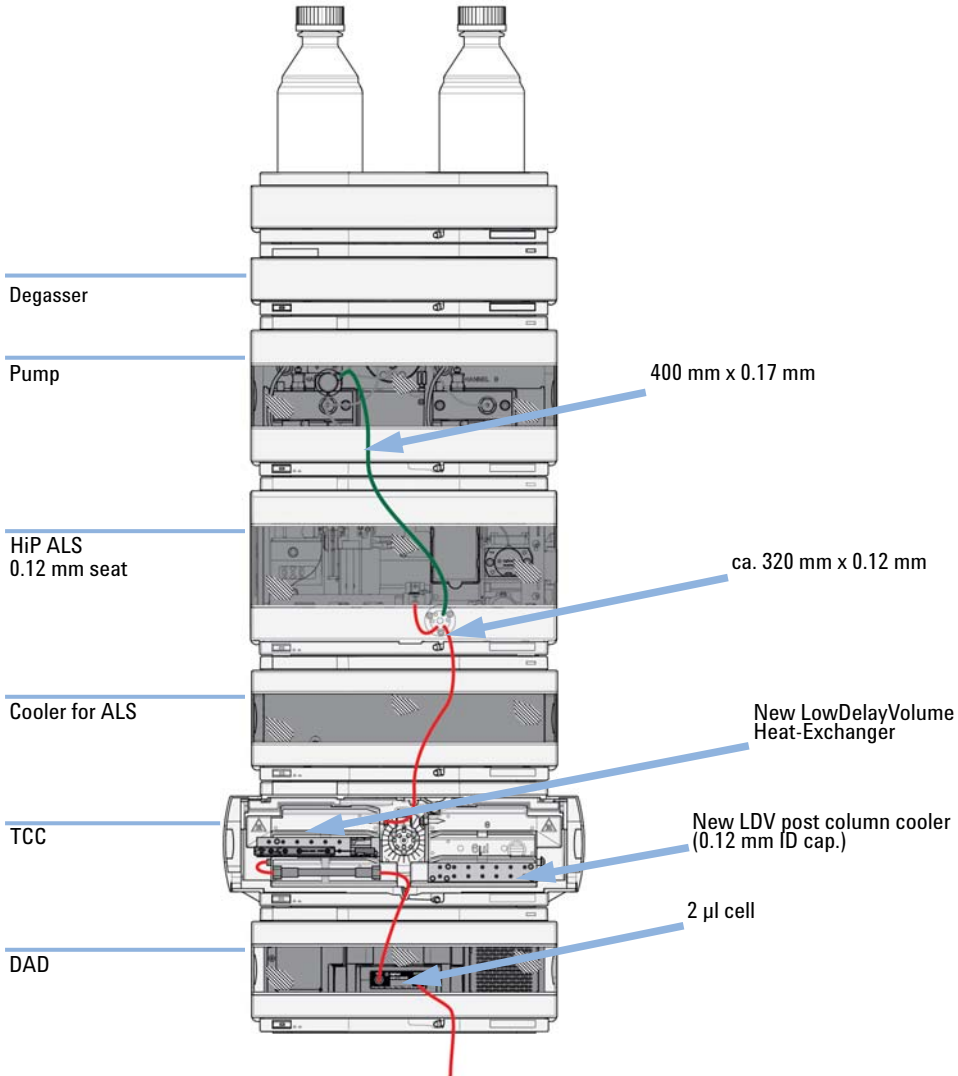

Figure 9 Agilent 1260 Infinity Binary LC in low delay volume configuration for 2.1 mm and 3.0 mm id columns

Agilent 1260 Infinity Binary LC in Low Delay Volume Configuration with Post Column Cooler

This configuration is usually used for short 2.1 mm and 3.0 mm columns optimized for high flow rates.

For a more detailed help on configuring your instrument, refer to the Agilent 1260 Infinity Binary LC System User Guide.

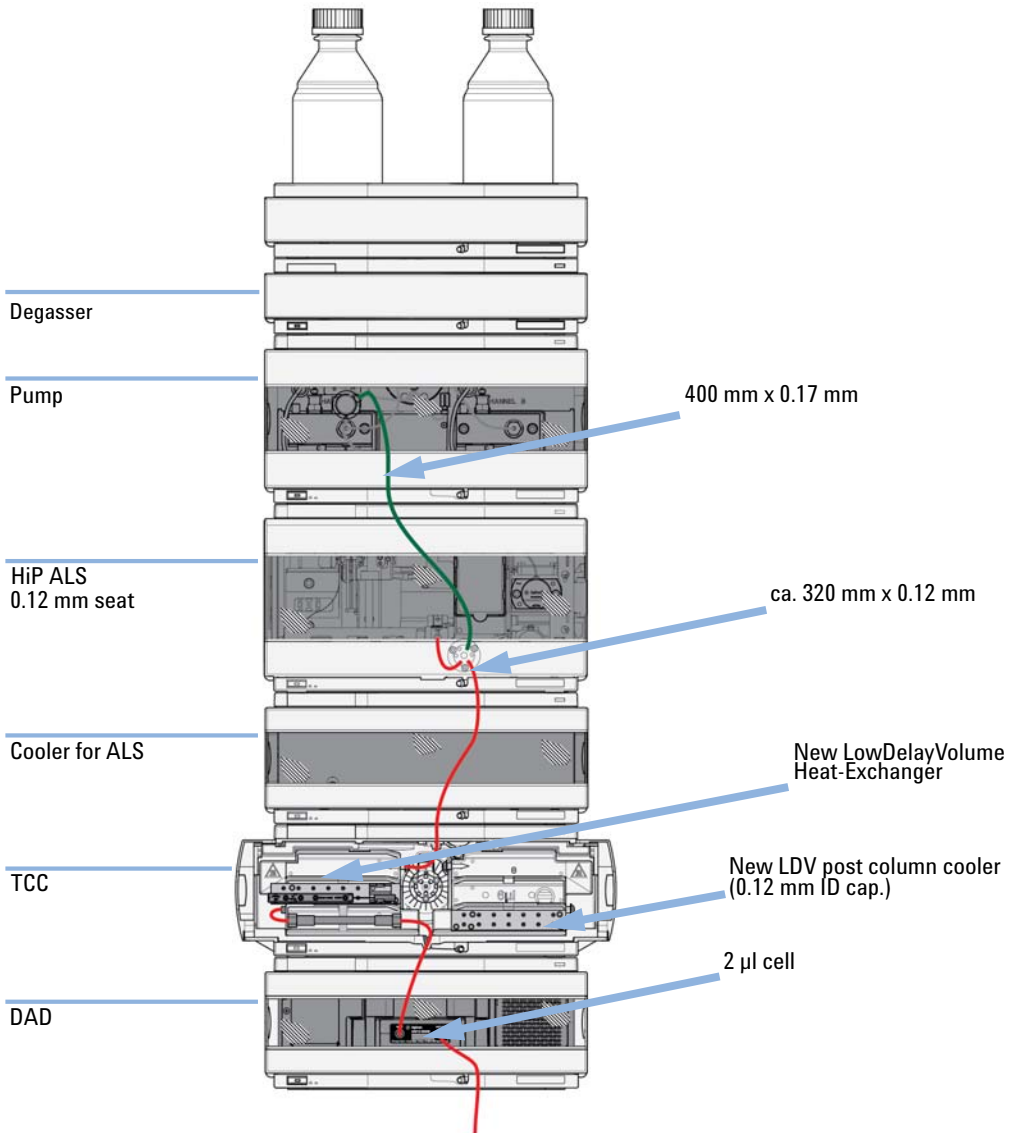

Figure 10 Agilent 1260 Infinity Binary LC in low delay volume configuration for 2.1 mm and 3.0 mm id columns

Agilent 1260 Infinity Binary LC in Low Delay Volume Configuration with Automated Column Regeneration and MS

This is the recommended setup to achieve minimum cycle time using MS detection.

For a more detailed help on configuring your instrument, refer to the Agilent 1260 Infinity Binary LC System User Guide.

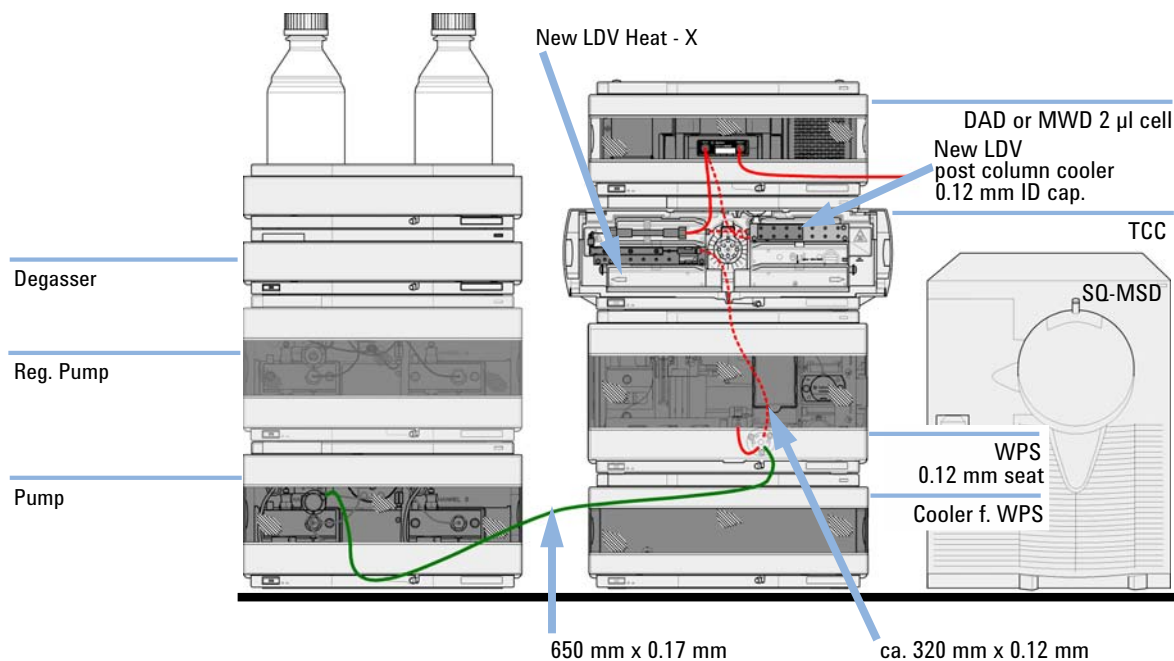

Figure 11 Agilent 1260 Infinity Binary LC with Automated column regeneration and MS detection in low delay volume configuration

Installation Information on Leak and Waste Handling

The Agilent 1200 Infinity Series has been designed for safe leak and waste handling. It is important that all security concepts are understood and instructions are carefully followed.

WARNING

Toxic, flammable and hazardous solvents, samples and reagents

The handling of solvents, samples and reagents can hold health and safety risks.

- When working with these substances observe appropriate safety procedures (for example by wearing goggles, safety gloves and protective clothing) as described in the material handling and safety data sheet supplied by the vendor, and follow good laboratory practice.
- The volume of substances should be reduced to the minimum required for the analysis.
- Never exceed the maximal permissible volume of solvents (6 L) in the solvent cabinet.
- Do not use bottles that exceed the maximum permissible volume as specified in the usage guideline for the Agilent 1200 Infinity Series Solvent Cabinets.
- Arrange the bottles as specified in the usage guideline for the solvent cabinet.
- A printed copy of the guideline has been shipped with the solvent cabinet, electronic copies are available on the Internet.

NOTE

Recommendations for Solvent Cabinet

For details, see the usage guideline for the Agilent 1200 Infinity Series Solvent Cabinets.

3 Installing the Pump

Installation Information on Leak and Waste Handling

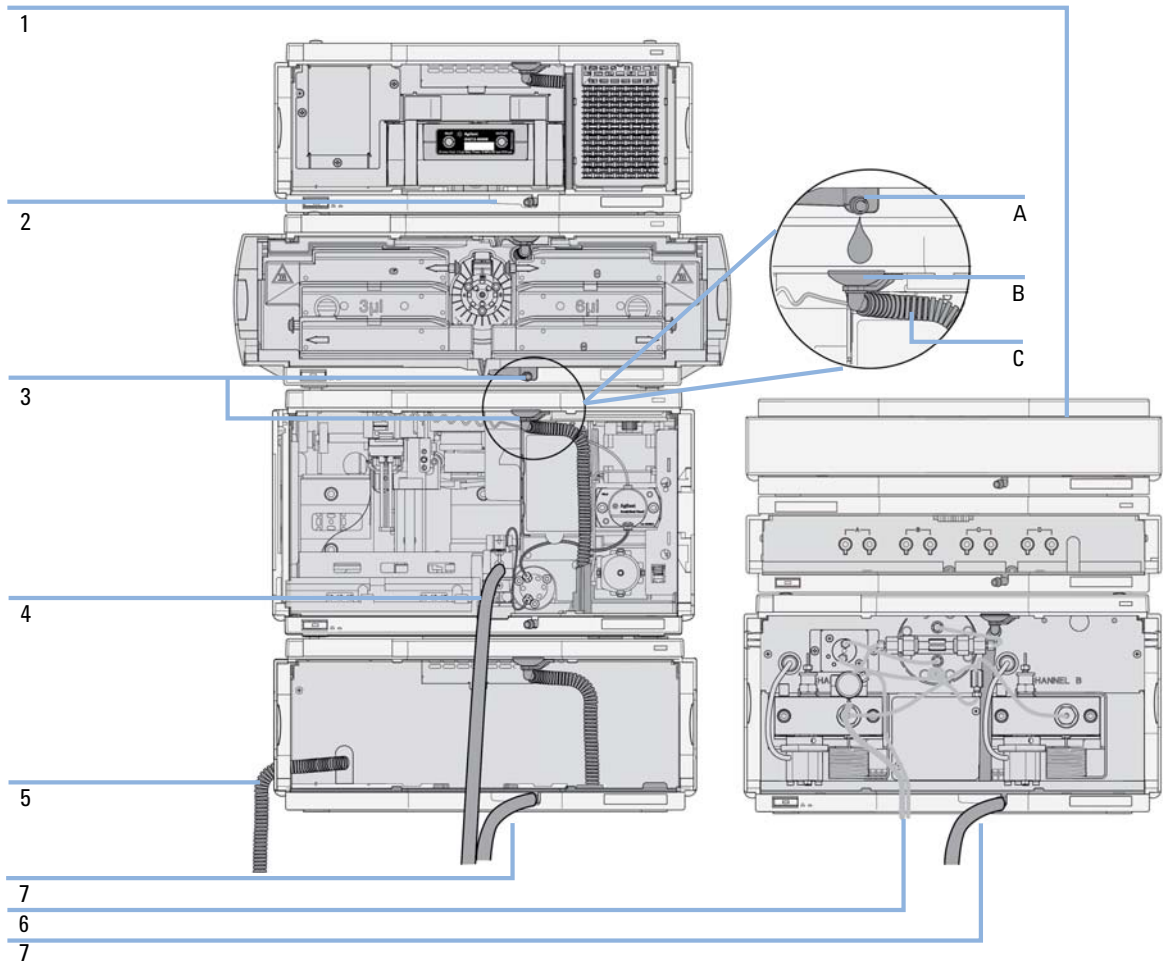

Figure 12 Leak and waste handling (overview - typical stack configuration as an example)

1	Solvent cabinet
2	Leak pan
3	Leak pan's outlet port (A), leak funnel (B) and corrugated waste tube (C)
4	Waste tube of the sampler's needle wash
5	Condense drain outlet of the autosampler cooler
6	Waste tube of the purge valve
7	Waste tube

- 1 Stack the modules according to the adequate stack configuration.
The leak pan outlet of the upper module must be vertically positioned above the leak tray of the lower module, see [Figure 12](#) on page 42.
- 2 Connect data and power cables to the modules, see section *Installing the Module* below.
- 3 Connect capillaries and tubes to the modules, see section *Flow Connections to the module* below or the relevant system manual.

WARNING

Toxic, flammable and hazardous solvents, samples and reagents

- Keep solvent path free from blockages.
- Keep the flow path closed (in case the pump in the system is equipped with a passive inlet valve, solvent may leak out due to hydrostatic pressure, even if your instrument is off).
- Avoid loops.
- Tubes must not sag.
- Do not bend tubes.
- Do not immerse tube end in waste liquid.
- Do not intubate tubes in other tubes.
- For correct tubing follow instructions on label attached to the module.

3 Installing the Pump

Installation Information on Leak and Waste Handling



Figure 13 Warning label (illustration for correct waste tubing)

Installing the Binary Pump

Parts required	#	p/n	Description
	1		Pump
	1		Data System and/or
	1	G4208A	Instant Pilot
	1		Power cord

For other cables see text below and “[Overview](#)” on page 202.

- Preparations**
- Locate bench space.
 - Provide power connections.
 - Unpack the module.

WARNING

Module is partially energized when switched off, as long as the power cord is plugged in.

Repair work at the module can lead to personal injuries, e.g. shock hazard, when the cover is opened and the module is connected to power.

- Make sure that it is always possible to access the power plug.
- Remove the power cable from the instrument before opening the cover.
- Do not connect the power cable to the Instrument while the covers are removed.

CAUTION

"Defective on arrival" problems

If there are signs of damage, please do not attempt to install the module. Inspection by Agilent is required to evaluate if the instrument is in good condition or damaged.

- Notify your Agilent sales and service office about the damage.
- An Agilent service representative will inspect the instrument at your site and initiate appropriate actions.

3 Installing the Pump

Installing the Binary Pump

- 1 Place the module on the bench in a horizontal position.
- 2 Ensure the power switch on the front of the pump is OFF (switch stands out).

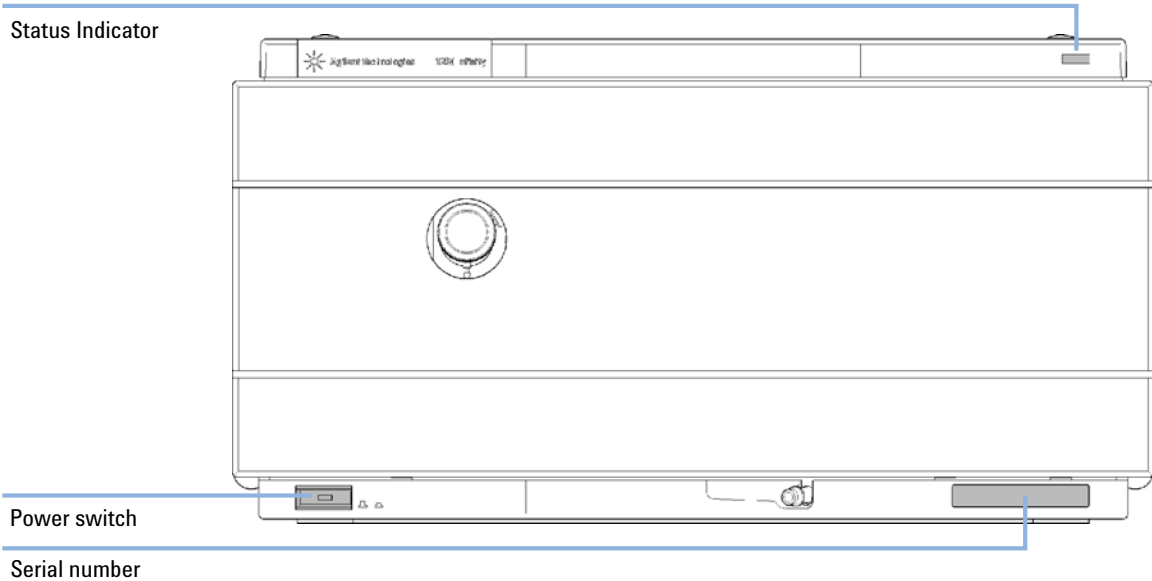

Figure 14 Front of Binary Pump

- 3 Connect the power cable to the power connector at the rear of the module.

- 4 Connect the required interface cables to the rear of the module.

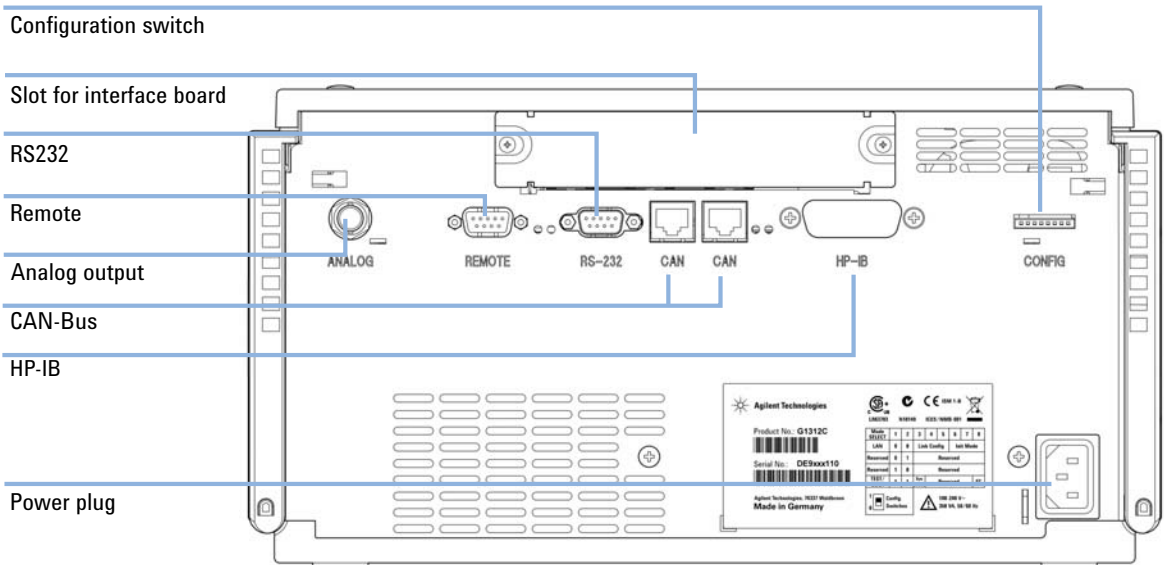

Figure 15 Rear of the Binary Pump

- 5 Connect the capillary, solvent tubes and waste tubings (see “[Flow Connections with Solvent Selection Valve](#)” on page 48 or “[Flow Connections without Solvent Selection Valve](#)” on page 51).
- 6 Press the power switch to turn on the module.

NOTE

The power switch stays pressed in and a green indicator lamp in the power switch is on when the module is turned on. When the line power switch stands out and the green light is off, the module is turned off.

- 7 Purge the pump (see “[Initial Priming](#)” on page 54).
The pump is shipped with default configuration settings. To change these settings, refer to “[Setting the 8-bit Configuration Switch \(without On-board\) LAN](#)” on page 228.

3 Installing the Pump

Flow Connections with Solvent Selection Valve

Flow Connections with Solvent Selection Valve

Parts required	#	p/n	Description
	1		Other modules
	1	G1311-68755	Accessory Kit
	2		wrenches 1/4 - 5/16 inch for capillary connections

Preparations Pump is installed in the LC system

WARNING

When opening capillary or tube fittings, solvents may leak out.

The handling of toxic and hazardous solvents and reagents can carry health risks.

- Observe appropriate safety procedures (for example, wear goggles, safety gloves and protective clothing) as described in the material handling and safety data sheet supplied by the solvent vendor, especially when toxic or hazardous solvents are used.

- 1 Remove the front cover by pressing the snap fasteners on both sides.

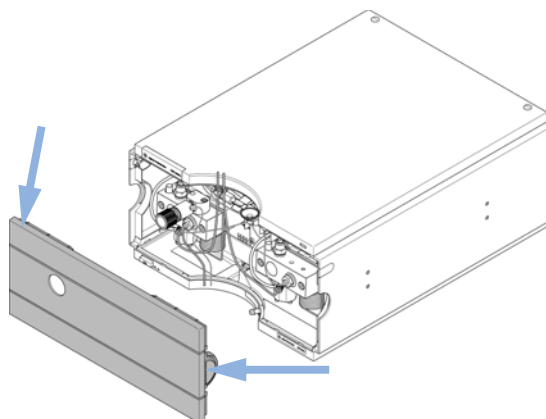

Figure 16 Removing the Front Cover

- 2 If available, place the online degasser on top of the pump.
- 3 Place the solvent cabinet on top of the module.
- 4 Set the four bottles into the solvent cabinet and screw a bottle head assembly onto each bottle.
- 5 Connect the solvent tubes from the bottle head assemblies to the inlet connectors A1, A2, B1 and B2 of the solvent selection valve. Make sure to use the brown bottle for the aqueous solvent (usually channel A1).
- 6 Label the tubes accordingly using the supplied stickers and fix the tubes in the clips of solvent cabinet and binary pump.
- 7 Hold the waste tubing with a piece of sandpaper and push it onto the purge valve outlet. Place the end into your waste system.
- 8 If the pump is not part of an Agilent 1260 Infinity system stack or placed on the bottom of a stack, connect the waste tube to the waste outlet of the pump leak handling system.
- 9 Connect the pump outlet capillary (pump to injection device) to the outlet of the purge valve.

3 Installing the Pump

Flow Connections with Solvent Selection Valve

10 Purge your system prior to the first use (see “Initial Priming” on page 54).

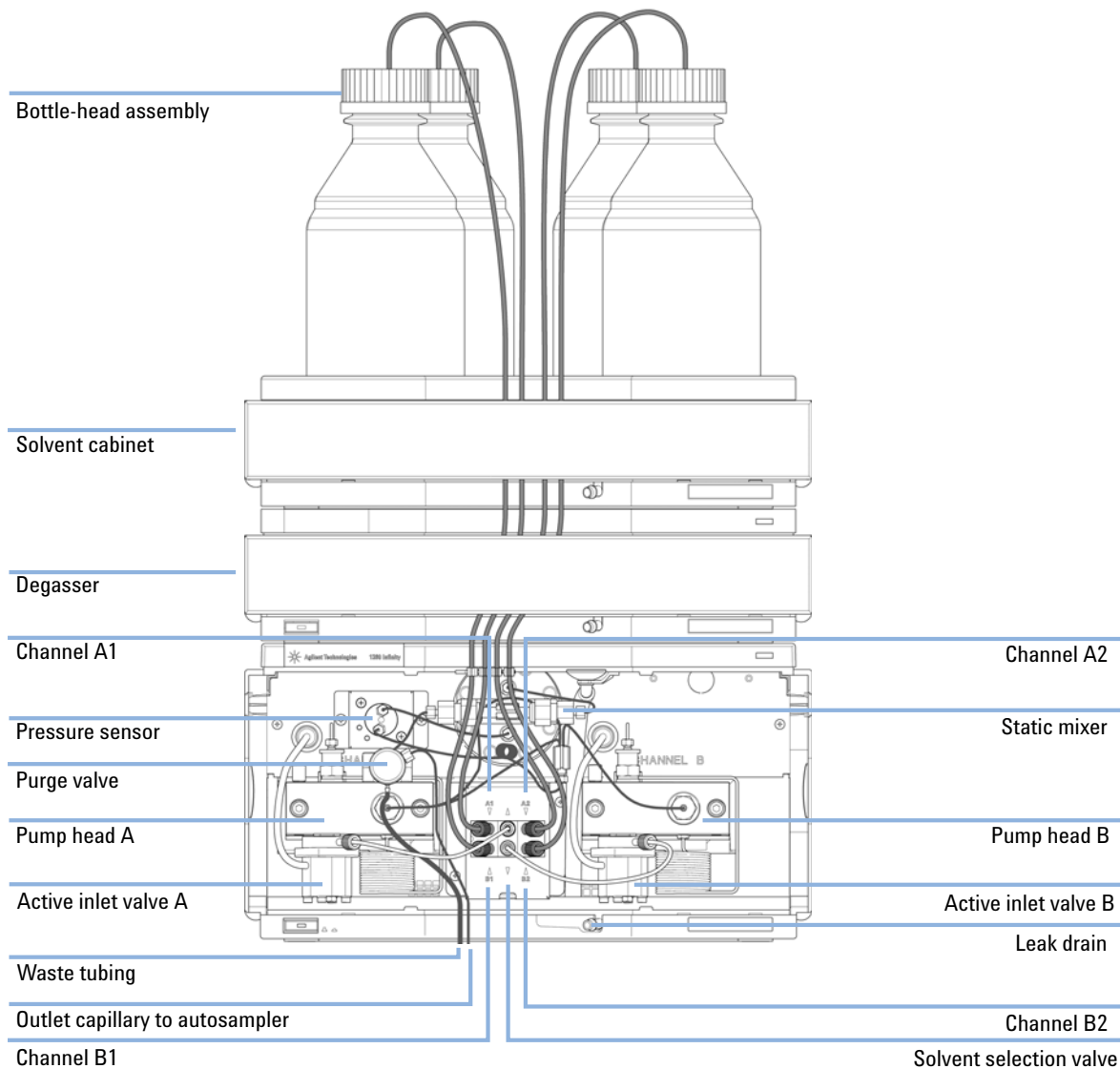

Figure 17 Binary Pump with Solvent Selection Valve

Flow Connections without Solvent Selection Valve

Parts required	#	p/n	Description
	1		Other modules
	1	G1311-68755	Accessory Kit
	2		wrenches 1/4 - 5/16 inch for capillary connections

Preparations Pump is installed in the LC system

WARNING

When opening capillary or tube fittings, solvents may leak out.

The handling of toxic and hazardous solvents and reagents can carry health risks.

- Observe appropriate safety procedures (for example, wear goggles, safety gloves and protective clothing) as described in the material handling and safety data sheet supplied by the solvent vendor, especially when toxic or hazardous solvents are used.

- 1 Remove the front cover by pressing the snap fasteners on both sides.

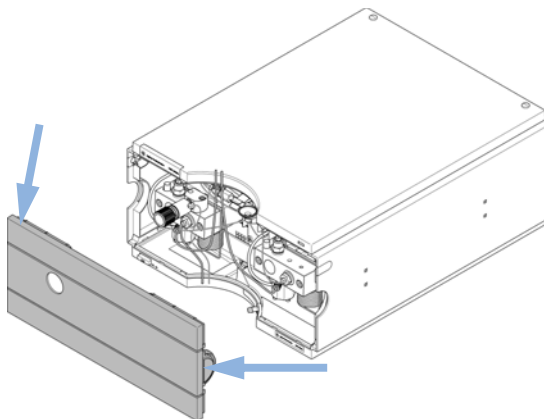

Figure 18 Removing the Front Cover

3 Installing the Pump

Flow Connections without Solvent Selection Valve

- 2** Place the solvent cabinet on top of the module.
- 3** Place the bottles into the solvent cabinet and place a bottle head assembly into each bottle.
- 4** Connect the solvent tubes from the bottle head assemblies to the inlet adapters of the active inlet valves. Fix the tubes in the clips of solvent cabinet and binary pump.
- 5** Hold the waste tubing with a piece of sandpaper and push it onto the purge valve outlet. Place the end into your waste system.
- 6** If the pump is not part of an Agilent 1260 Infinity system stack or placed on the bottom of a stack, connect the waste tube to the waste outlet of the pump leak handling system.
- 7** Connect the pump outlet capillary (pump to injection device) to the outlet of the purge valve.

8 Purge your system before first use (see “Initial Priming” on page 54).

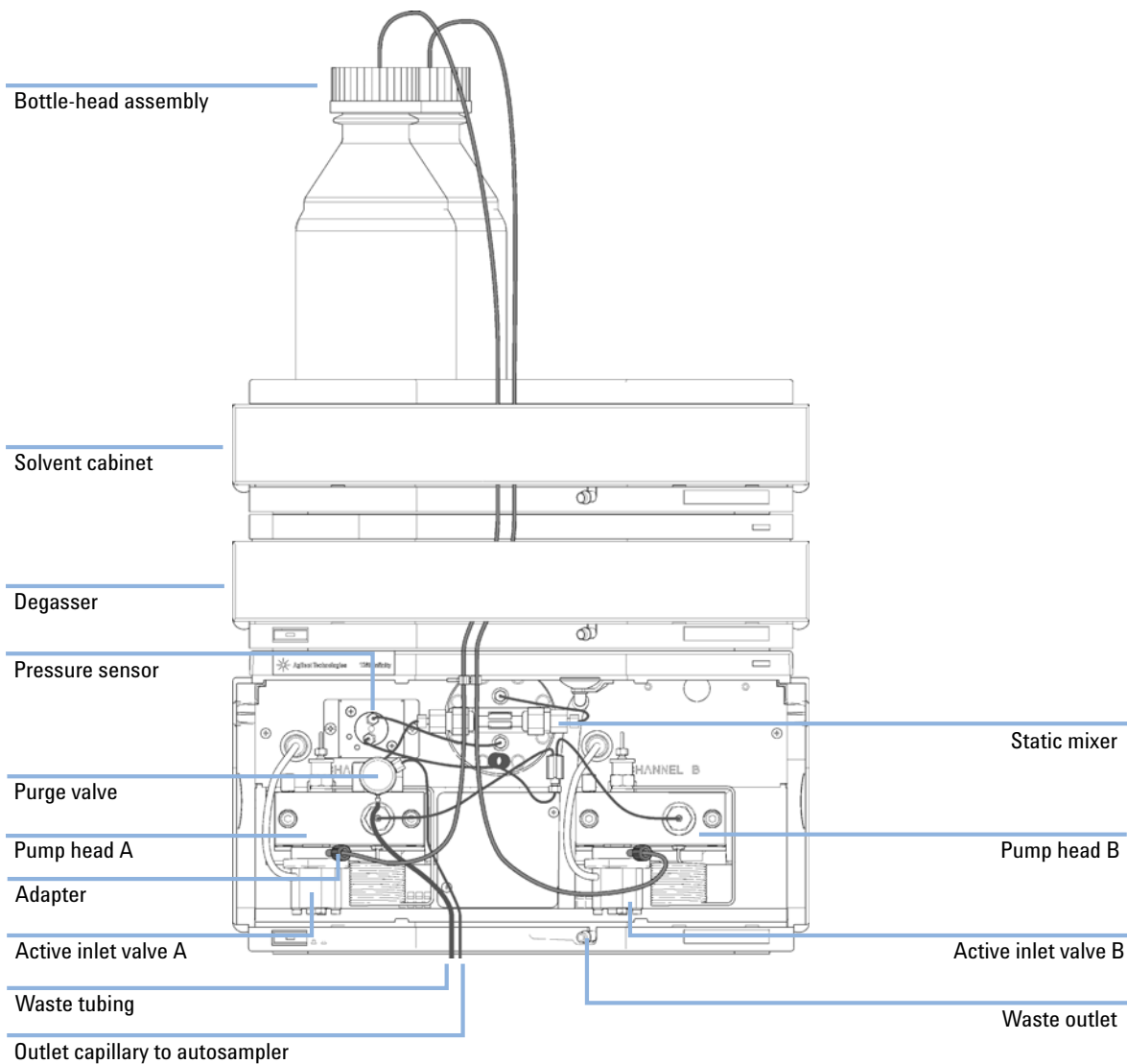

Figure 19 Flow Connection of Binary Pump without Solvent Selection Valve

Priming the System

Initial Priming

When Before a degasser or solvent tubing can be used, it is necessary to prime the system. Isopropanol is recommended as priming solvent due to its miscibility with nearly all HPLC solvents and its excellent wetting properties.

Parts required	#	Description
	1	Isopropanol

Preparations Connect all modules hydraulically as described in the respective module manuals.
Fill each solvent bottle with 100 mL isopropanol
Switch the system on

WARNING

When opening capillary or tube fittings, solvents may leak out.

The handling of toxic and hazardous solvents and reagents can carry health risks.

→ Observe appropriate safety procedures (for example, wear goggles, safety gloves and protective clothing) as described in the material handling and safety data sheet supplied by the solvent vendor, especially when toxic or hazardous solvents are used.

NOTE

The purge tool of the Lab Advisor can be used to purge the pump automatically.

NOTE

If the pump is not able to draw in the solvent from the bottles, use a syringe to move the solvent manually through tubing and degasser.

NOTE

When priming the vacuum degasser with a syringe, the solvent is drawn through the degasser tubes very quickly. The solvent at the degasser outlet will therefore not be fully degassed. Pump for approximately 10 minutes at your desired flow rate before starting an analysis. This will allow the vacuum degasser to properly degas the solvent in the degasser tubes.

- 1** Open the purge valve of the pump
- 2** Set the flow rate to 5 mL/min.
- 3** Select channel A1
- 4** Turn the flow on
- 5** Observe if the solvent in the tubing of channel A1 is advancing towards the pump. If it isn't, disconnect the solvent tubing from the solvent selection valve, attach a syringe with a syringe adapter and pull the liquid through the degasser. Reattach the tubing to the solvent selection valve.
- 6** Pump 30 mL isopropanol to remove residual air bubbles.
- 7** Switch to the next solvent channel and repeat steps 5 and 6 until all channels have been purged.
- 8** Turn the flow off and close the purge valve.

Regular Priming

When When the pumping system has been turned off for a certain time (for example, overnight) air will rediffuse into the solvent channel between the vacuum degasser and the pump. If solvents containing volatile components are left in the degasser without flow for a prolonged period, there will be a slight loss of the volatile components.

Preparations Switch the system on

NOTE

The purge tool of the Lab Advisor can be used for automatically purging the pump.

- 1 Open the purge valve of your pump by turning it counterclockwise and set the flow rate to 5 mL/min.
- 2 Flush the vacuum degasser and all tubes with at least 10 mL of solvent.
- 3 Repeat step 1 and 2 for the other channel(s) of the pump.
- 4 Set the required composition and flow rate for your application and close the purge valve.
- 5 Pump for approximately 10 minutes before starting your application.

Changing Solvents

When When the solvent of a channel is to be replaced by another solvent that is not compatible (solvents are immiscible or one solvent contains a buffer), it is necessary to follow the procedure below to prevent clogging of the pump by salt precipitation or residual liquid droplets in parts of the system.

Parts required	#	p/n	Description
	1		Purging solvent(s), see Table 3 on page 58
	1	5022-2184	Union ZDV

Preparations Remove the column and replace it by a ZDV fitting
Prepare bottles with appropriate intermediate solvents (see [Table 3](#) on page 58)

- 1 If the channel is not filled with buffer, proceed to step 4.
- 2 Place the solvent intake filter into a bottle of water.
- 3 Flush the channel at a flow rate suitable for the installed tubing (typically 3 – 5 mL/min) for 10 min.
- 4 Modify the flow path of your system as required for your application. For delay volume optimization, see the Binary LC System User Guide.

CAUTION

Buffer salt of aqueous buffers may precipitate in residual isopropanol.

Capillaries and filter may be clogged by precipitating salt.

- Flush solvent lines containing high concentration of salts first with water before introducing organic solvent.
- Do not perform steps 5 to 7 for channels running with aqueous buffer as solvent.

- 5 Replace the solvent bottle by a bottle of isopropanol.
- 6 Flush the channel at a flow rate suitable for the installed tubing (typically 3 – 5 mL/min) for 5 min.
- 7 Swap the bottle of isopropanol with a bottle of solvent for your application.
- 8 Repeat steps 1 to 7 for the other channel(s) of the pump.
- 9 Install the desired column, set the required composition and flow rate for your application and equilibrate the system for approx. 10 minutes prior to starting a run.

3 Installing the Pump

Priming the System

Table 3 Choice of Priming Solvents for Different Purposes

Activity	Solvent	Comments
After an installation	Isopropanol	Best solvent to flush air out of the system
When switching between reverse phase and normal phase (both times)	Isopropanol	Miscible with almost all solvents
After an installation	Ethanol or methanol	Alternative to isopropanol (second choice) if no isopropanol is available
To clean the system when using buffers	HPLC grade water	Best solvent to re-dissolve buffer crystals
After changing aqueous solvents	HPLC grade water	Best solvent to re-dissolve buffer crystals
After the installation of normal phase seals (PE seals (pack of 2) (0905-1420))	Hexane + 5 % isopropanol	Good wetting properties



4 Using the Pump

Leak and Waste Handling	60
Hints for Successful Use of the Binary Pump	61
Setting up the Pump with the G4208A Instant Pilot	62
Setting up the Agilent 1260 Infinity Binary Pump G1312B with the Instrument Control Interface	63
Overview	63
Setup of Basic Pump Parameters	64
Pump Control	65
Auxiliary Pump Parameters	66
Data Curves	67
Bottle Filling	67
Solvent Information	69
Algae Growth in HPLC Systems	74
How to Prevent and/or Reduce the Algae Problem	75
Prevent Blocking of Solvent Filters	76
Checking the Solvent Filters	77
Cleaning the Solvent Filters	77

This chapter explains the operational parameters of the binary pump.



Leak and Waste Handling

WARNING

Toxic, flammable and hazardous solvents, samples and reagents

The handling of solvents, samples and reagents can hold health and safety risks.

- When working with these substances observe appropriate safety procedures (for example by wearing goggles, safety gloves and protective clothing) as described in the material handling and safety data sheet supplied by the vendor, and follow good laboratory practice.
- The volume of substances should be reduced to the minimum required for the analysis.
- Do not operate the instrument in an explosive atmosphere.
- Never exceed the maximal permissible volume of solvents (6 L) in the solvent cabinet.
- Do not use bottles that exceed the maximum permissible volume as specified in the usage guideline for the Agilent 1200 Infinity Series Solvent Cabinets.
- Arrange the bottles as specified in the usage guideline for the solvent cabinet.
- A printed copy of the guideline has been shipped with the solvent cabinet, electronic copies are available on the Internet.
- The residual free volume in the appropriate waste container must be large enough to collect the waste liquid.
- Check the filling level of the waste container regularly.
- To achieve maximal safety, check the correct installation regularly.

NOTE

Recommendations for Solvent Cabinet

For details, see the usage guideline for the Agilent 1200 Infinity Series Solvent Cabinets.

For details on correct installation, see [“Installation Information on Leak and Waste Handling”](#) on page 41.

Hints for Successful Use of the Binary Pump

- Place solvent cabinet with the solvent bottles always on top (or at a higher level) of the pump.
- When using the binary pump without vacuum degasser, shortly degas your solvents by putting the solvent to a suitable container and applying a vacuum pressure for some time. If possible apply solvent conditions that will decrease the gas solubility over time (for example, warming up the solvents).
- The use of a vacuum degasser is mandatory for flow rates below 0.5 mL/min and for configurations without damper and mixer.
- When using the binary pump with vacuum degasser, flush the degasser with at least 5 mL per channel before operating the pump, especially when the pumping system had been turned off for a certain length of time (for example, overnight) and volatile solvent mixtures are used in the channels (see [“Regular Priming”](#) on page 56).
- Prevent blocking of solvent inlet filters (never use the pump without solvent inlet filters). Growth of algae should be avoided (see [“Prevent Blocking of Solvent Filters”](#) on page 76).
- Check purge valve frit and column frit in regular time intervals. A blocked purge valve frit can be identified by black, yellow or greenish layers on its surface or by a pressure greater than 10 bar in low delay volume configuration and 20 bar in standard configuration when pumping distilled water at a rate of 5 mL/min with an open purge valve.
- Whenever possible use a minimum flow rate of 5 μ L/min per solvent channel to avoid crossflow of solvent into the unused pump channel.
- Whenever exchanging the pump seals, the purge valve frit should be exchanged, too.
- When using buffer solutions, flush the system with water before switching it off. The seal wash option should be used when buffer solutions with concentrations of 0.1 M or higher are being pumped for long periods of time.
- Check the pump pistons for scratches, grooves and dents when changing the piston seals. Damaged pistons cause micro leaks and will decrease the lifetime of the seals.
- After changing the piston seals, apply the seal wear-in procedure (see [“Seal Wear-in Procedure”](#) on page 169).
- Place the aqueous solvent on channel A and the organic solvent on channel B. The default compressibility settings are set accordingly.

4 Using the Pump

Setting up the Pump with the G4208A Instant Pilot

Setting up the Pump with the G4208A Instant Pilot

Generic operation of the G4208A Instant Pilot is covered in the Agilent Instant Pilot G4208A User's Guide (G4208-90006). Details about setting up module specific parameters can be found in the Instant Pilot online help.

The pump parameters are described in detail in [“Overview”](#) on page 63.

Setting up the Agilent 1260 Infinity Binary Pump G1312B with the Instrument Control Interface

Overview

Parameters described in following sections is offered by the instrument control interface and can usually be accessed through Agilent instrument control software. For details, please refer to manuals and online help of respective user interfaces.

Setup of Basic Pump Parameters

The most important parameters of the pump are listed in [Table 4](#) on page 64.

Table 4 Basic pump parameters

Parameter	Limits	Description
• Flow	0.001 – 5 mL/min	Total flow rate of the pump. See “When to Remove Damper and Mixer” on page 84 for pump hardware modifications to achieve lowest delay volume.
• Stop Time	0.01 min - no limit	The stop time of the pump usually controls the run time of the whole LC system. Use no limit to stop the run manually (useful for method development).
• Post Time	off - 99999 min	Time between the end of a run and the start of the next. Used for column equilibration after a gradient.
• Pressure Limits	Max: 0 – 600 bar Min: 0 – 600 bar	Max must be bigger than Min ! Set max pressure to the maximum operating pressure of your column. A min pressure setting of e.g. 10 bar will turn off your pump automatically when running out of solvent. A smarter way, however, is to use the bottle fillings function (see “Bottle Filling” on page 67).
• Solvent A	0 – 100 %	Although channel A can be set to 0 %, it cannot be turned off. This channel should be used for the aqueous phase (water).
• Solvent B	off - 100 %	The percentage of channel B is automatically complemented by channel A to give 100 %.
• Solvent type	H ₂ O, ACN, MeOH, IPA	Select the solvent you are using in the respective solvent channel from the drop-down list. In case your solvent is not listed, perform a solvent compressibility calibration (see “Running the Solvent Compressibility Calibration” on page 134. For details on solvent compressibility see “Binary Pump Solvent Compressibility Calibration” on page 133.
• Solvent Comment		Free text field for a description of the solvent. This description will show up in method printouts, etc.
• Timetable	max. number of lines depends on free space in pump memory	Use the timetable to build solvent gradients, flow gradients, or combinations of both. Gradients are always linear. Use multiple timetable entries to mimic exponential or parabolic gradients.
• Display		There are three ways to display the timetable: <ul style="list-style-type: none"> • in tabular form • as flow/pressure graph • as solvent percentage plot Values can only be changed in tabular view.

Pump Control

The pump can be switched between following states: **On**, **Off** or to **Standby**. In **Standby**, the pump motor is still controlled. When the pump is switched on from standby, it does not re-initialize.

CAUTION

Upon initialization, the pump ignores the Maximum Flow Gradient value.

This can result in a rapid and uncontrolled pressure increase.

→ To prevent harm to the column, open the purge valve until the initialization is finished.

The optional seal wash pump can be controlled by either switching it off, using it for a single time or specifying frequency and duration of periodic wash intervals.

Auxiliary Pump Parameters

The auxiliary pump parameters are pre-set to fit most applications. Adjustments should only be made when required. [Table 5](#) on page 66 shows the available auxiliary parameters with their default values.

CAUTION

Upon initialization, the pump ignores the Maximum Flow Gradient value.

This can result in a rapid and uncontrolled pressure increase.

→ To prevent harm to the column, open the purge valve until the initialization is finished.

Table 5 Auxiliary pump parameters

Parameter	Limits	Description
• Maximum Flow Gradient	0.1 – 100 mL/min ² default: 100 mL/min ²	With this parameter flow rate changes can be ramped up and down slowly to avoid pressure shocks to the column. The default value is 100 mL/min ² which in fact turns the function off.
• Minimum Stroke	20 – 100 µL default: Auto	The volume one pump piston delivers per stroke. In general, a smaller stroke volume results in lower pump ripple. The Auto setting adjusts the strokes dynamically to the lowest possible value. The strokes can be set individually for pump heads A and B.
• Compressibility	0 - 150·10 ⁻⁶ /bar bar or enhanced compressibility calibration default: use enhanced comp. calibration	For best performance, check option Use enhanced compressibility calibration . With this option, the pump will use solvent data libraries provided by Agilent or data generated by using solvent compressibility calibrations (see “Running the Solvent Compressibility Calibration” on page 134). For details on solvent compressibility see “Binary Pump Solvent Compressibility Calibration” on page 133. For backward compatibility to 400 bar pumps, the solvent compressibility can still be set manually for each channel when the box is unticked.

Data Curves

The binary pump provides the possibility to store the following operational data in the data file of the Agilent data system:

- Solvent percentage for each channel,
- pump flow,
- pressure

NOTE

The pressure data curve is *generated* from the pressure sensor readings, while %A, %B and flow are *calculated* from the method settings of the pump.

For details, please refer to the online help or manual of your instrument control software.

Bottle Filling

The pump offers a powerful feature to monitor the liquid level in the solvent bottles. With total bottle volume and initial filling volume set correctly, the pump subtracts the consumed volume continuously from the initial value and stops the pump and method/sequence execution before the system runs dry or an analysis is corrupted.

CAUTION

The bottle filling feature fails if multiple solvent inlets are put into one solvent bottle!

→ In that case implement a minimum pressure limit (see [Table 4](#) on page 64) to avoid that the pump runs dry when solvents are empty.

[Table 6](#) on page 68 lists the available bottle filling parameters.

4 Using the Pump

Setting up the Agilent 1260 Infinity Binary Pump G1312B with the Instrument Control Interface

Table 6 Bottle Filling Parameters

Parameter	Limits	Description
• Total Volume	0 – 1000 L default: 0 L	This is the capacity (maximum possible volume) in liter of the solvent bottle. In combination with the actual volume, this parameter is used for calculating and displaying the relative liquid level.
• Actual Volume	0 – 1000 L default: 0 L	After filling the solvent bottles, enter the actual volumes into these boxes. The Actual Volume must not be larger than the Total Volume of the bottle.
• Prevent analysis.....	default: unchecked	If this option is checked, the pump won't start a new run if the solvent level in one or more bottles is below the minimum volume. Enter a minimum volume in liter, which considers the position of the solvent inlet and size/shape of the solvent bottle such that no air is drawn if the actual volume gets close to this limit.
• Turn pump off...	default: unchecked	If this option is checked, the pump will turn off before air is aspirated. However, the residual solvent volume has been calculated for 1 L solvent bottles and may be too small for large bottles or other vessels.

Solvent Information

Observe the following recommendations on the use of solvents.

- Follow recommendations for avoiding the growth of algae, see [“Algae Growth in HPLC Systems”](#) on page 74
- Small particles can permanently block capillaries and valves. Therefore, always filter solvents through 0.4 µm filters.
- Avoid or minimize the use of solvents that may corrode parts in the flow path. Consider specifications for the pH range given for different materials like flow cells, valve materials etc. and recommendations in subsequent sections.

Materials in Flow Path

Following materials are used in the flow path of this module:

Table 7 Materials in flow path

Part	Materials
SSV	PEEK, FFKM
Active inlet valve	SST, sapphire, ruby, ceramic, PTFE
Outlet valve	SST, gold, ruby, ZrO ₂ -based ceramic, tantalum
Adapter	SST, gold
Pump head (body)	SST
Pistons	Sapphire
Piston seals/wash seals	PTFE, SST (reversed phase) or UHMW-PE, SST (normal phase)
Pressure sensor	SST
Purge valve	SST, gold, PTFE, ceramic
Damping unit	SST, gold
Capillaries/fittings	SST
Tubings	PTFE

Material Information

Materials in the flow path are carefully selected based on Agilent's experiences in developing highest quality instruments for HPLC analysis over several decades. These materials exhibit excellent robustness under typical HPLC conditions. For any special conditions, please consult the material information section or contact Agilent.

Disclaimer

Subsequent data were collected from external resources and are meant as a reference. Agilent cannot guarantee the correctness and completeness of such information. Data is based on compatibility libraries, which are not specific for estimating the long-term life time under specific but highly variable conditions of UHPLC systems, solvents, solvent mixtures and samples. Information can also not be generalized due to catalytic effects of impurities like metal ions, complexing agents, oxygen etc. Apart from pure chemical corrosion, other effects like electro corrosion, electrostatic charging (especially for non-conductive organic solvents), swelling of polymer parts etc. need to be considered. Most data available refers to room temperature (typically 20 – 25 °C, 68 – 77 °F). If corrosion is possible, it usually accelerates at higher temperatures. If in doubt, please consult technical literature on chemical compatibility of materials.

PEEK

PEEK (Polyether-Ether Ketones) combines excellent properties regarding biocompatibility, chemical resistance, mechanical and thermal stability. PEEK is therefore the material of choice for UHPLC and biochemical instrumentation.

It is stable in a wide pH range, and inert to many common solvents.

There is still a number of known incompatibilities with chemicals such as chloroform, methylene chloride, THF, DMSO, strong acids (nitric acid > 10 %, sulphuric acid > 10 %, sulfonic acids, trichloroacetic acid), halogenes or aqueous halogene solutions, phenol and derivatives (cresols, salicylic acid etc.).

Polyimide

Agilent uses semi-crystalline polyimide for rotor seals in valves and needle seats in autosamplers. One supplier of polyimide is DuPont, which brands polyimide as Vespel, which is also used by Agilent.

Polyimide is stable in a pH range between 1 and 10 and in most organic solvents. It is incompatible with concentrated mineral acids (e.g. sulphuric acid), glacial acetic acid, DMSO and THF. It is also degraded by nucleophilic substances like ammonia (e.g. ammonium salts in basic conditions) or acetates.

Polyethylene (PE)

Agilent uses UHMW (ultra-high molecular weight)-PE/PTFE blends for yellow piston and wash seals, which are used in 1290 Infinity pumps and for normal phase applications in 1260 Infinity pumps.

Polyethylene has a good stability for most common inorganic solvents including acids and bases in a pH range of 1 to 12.5 . It is compatible to many organic solvents used in chromatographic systems like methanol, acetonitrile and isopropanol. It has limited stability with aliphatic, aromatic and halogenated hydrocarbons, THF, phenol and derivatives, concentrated acids and bases. For normal phase applications, the maximum pressure should be limited to 200 bar.

Tantalum (Ta)

Tantalum is inert to most common HPLC solvents and almost all acids except fluoric acid and acids with free sulfur trioxide. It can be corroded by strong bases (e.g. hydroxide solutions > 10 %, diethylamine). It is not recommended for the use with fluoric acid and fluorides.

Stainless Steel (ST)

Stainless steel is inert against many common solvents. It is stable in the presence of acids and bases in a pH range of 1 to 12.5 . It can be corroded by acids below pH 2.3 . It can also corrode in following solvents:

- Solutions of alkali halides, their respective acids (for example, lithium iodide, potassium chloride, and so on) and aqueous solutions of halogens.

4 Using the Pump Solvent Information

- High concentrations of inorganic acids like nitric acid, sulfuric acid and organic solvents especially at higher temperatures (replace, if your chromatography method allows, by phosphoric acid or phosphate buffer which are less corrosive against stainless steel).
- Halogenated solvents or mixtures which form radicals and/or acids, for example:

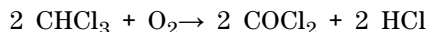

This reaction, in which stainless steel probably acts as a catalyst, occurs quickly with dried chloroform if the drying process removes the stabilizing alcohol.

- Chromatographic grade ethers, which can contain peroxides (for example, THF, dioxane, di-isopropylether). Such ethers should be filtered through dry aluminium oxide which adsorbs the peroxides.
- Solutions of organic acids (acetic acid, formic acid, and so on) in organic solvents. For example, a 1 % solution of acetic acid in methanol will attack steel.
- Solutions containing strong complexing agents (for example, EDTA, ethylene diamine tetra-acetic acid).
- Mixtures of carbon tetrachloride with 2-propanol or THF.

Diamond-Like Carbon (DLC)

Diamond-Like Carbon is inert to almost all common acids, bases and solvents. There are no documented incompatibilities for HPLC applications.

Fused silica and Quartz (SiO₂)

Fused silica is used in 1290 Infinity Flow Cells and capillaries. Quartz is used for classical flow cell windows. It is inert against all common solvents and acids except hydrofluoric acid and acidic solvents containing fluorides. It is corroded by strong bases and should not be used above pH 12 at room temperature. The corrosion of flow cell windows can negatively affect measurement results. For a pH greater than 12, the use of flow cells with sapphire windows is recommended.

Gold

Gold is inert to all common HPLC solvents, acids and bases within the specified pH range. It can be corroded by complexing cyanides and concentrated acids like aqua regia.

Zirconium Oxide (ZrO₂)

Zirconium Oxide is inert to almost all common acids, bases and solvents. There are no documented incompatibilities for HPLC applications.

Platinum/Iridium

Platinum/Iridium is inert to almost all common acids, bases and solvents. There are no documented incompatibilities for HPLC applications.

Fluorinated polymers (PTFE, PFA, FEP, FFKM)

Fluorinated polymers like PTFE (polytetrafluorethylene), PFA (perfluoroalkoxy) and FEP (fluorinated ethylene propylene) are inert to almost all common acids, bases, and solvents. FFKM is perfluorinated rubber, which is also resistant to most chemicals. As an elastomer, it may swell in some organic solvents like halogenated hydrocarbons.

TFE/PDD copolymer tubings, which are used in all Agilent degassers except G1322A, are not compatible with fluorinated solvents like Freon, Fluorinert, or Vertrel. They have limited life time in the presence of Hexafluoroisopropanol (HFIP). To ensure the longest possible life with HFIP, it is best to dedicate a particular chamber to this solvent, not to switch solvents, and not to let dry out the chamber. For optimizing the life of the pressure sensor, do not leave HFIP in the chamber when the unit is off.

Sapphire, Ruby and Al₂O₃-based ceramics

Sapphire, ruby and ceramics based on aluminum oxide Al₂O₃ are inert to almost all common acids, bases and solvents. There are no documented incompatibilities for HPLC applications.

Algae Growth in HPLC Systems

The presence of algae in HPLC systems can cause a variety of problems that may be incorrectly diagnosed as instrument or application problems. Algae grow in aqueous media, preferably in a pH range of 4-8. Their growth is accelerated by buffers, for example phosphate or acetate. Since algae grow through photosynthesis, light will also stimulate their growth. Even in distilled water small-sized algae grow after some time.

Instrumental Problems Associated With Algae

Algae deposit and grow everywhere within the HPLC system causing:

- Blocked solvent filters or deposits on inlet or outlet valves resulting in unstable flow, composition or gradient problems or a complete failure of the pump.
- Small pore high pressure solvent filters, usually placed before the injector to plug resulting in high system pressure.
- PTFE frits blockage leading to increased system pressure.
- Column filters to plug giving high system pressure.
- Flow cell windows of detectors to become dirty resulting in higher noise levels (since the detector is the last module in the flow path, this problem is less common).

How to Prevent and/or Reduce the Algae Problem

- Always use freshly prepared solvents, especially use demineralized water which was filtered through about 0.2 μm filters.
- Never leave mobile phase in the instrument for several days without flow.
- Always discard old mobile phase.
- Use the amber solvent bottle (Solvent bottle, amber (9301-1450)) supplied with the instrument for your aqueous mobile phase.
- If possible add a few mg/l sodium azide or a few percent organic solvent to the aqueous mobile phase.

Prevent Blocking of Solvent Filters

Contaminated solvents or algae growth in the solvent bottle will reduce the lifetime of the solvent filter and will influence the performance of the module. This is especially true for aqueous solvents or phosphate buffers (pH 4 to 7). The following suggestions will prolong lifetime of the solvent filter and will maintain the performance of the module.

- Use a sterile, if possible amber, solvent bottle to slow down algae growth.
- Filter solvents through filters or membranes that remove algae.
- Exchange solvents every two days or refilter.
- If the application permits add 0.0001 – 0.001 M sodium azide to the solvent.
- Place a layer of argon on top of your solvent.
- Avoid exposure of the solvent bottle to direct sunlight.

NOTE

Never use the system without solvent filter installed.

Checking the Solvent Filters

The solvent filters are located on the low-pressure side of the binary pump. A blocked filter therefore does not necessarily affect the high pressure readings of the pump. The pressure readings cannot be used to check whether the filters are blocked or not. If the solvent cabinet is placed on top of the binary pump, the filter condition can be checked in the following way:

Remove the solvent inlet tube from the inlet port of the solvent selection valve or the adapter at the active inlet valve. If the filter is in good condition, the solvent will freely drip out of the solvent tube (due to hydrostatic pressure). If the solvent filter is partly blocked only very little solvent will drip out of the solvent tube.

WARNING

When opening capillary or tube fittings, solvents may leak out.

The handling of toxic and hazardous solvents and reagents can carry health risks.

- Observe appropriate safety procedures (for example, wear goggles, safety gloves and protective clothing) as described in the material handling and safety data sheet supplied by the solvent vendor, especially when toxic or hazardous solvents are used.

Cleaning the Solvent Filters

- Remove the blocked solvent filter from the bottle-head assembly and place it in a beaker with concentrated nitric acid (35%) for one hour.
- Thoroughly flush the filter with HPLC-grade water (remove all nitric acid, some capillary columns can be damaged by nitric acid).
- Replace the filter.

NOTE

Never use the system without solvent filter installed.

4 Using the Pump

Prevent Blocking of Solvent Filters



5 Optimizing Performance

When to Use a Vacuum Degasser	80
Operational Hints for the Vacuum Degasser	80
When to Use the Active Seal Wash Option	81
When to Use Alternative Seals	82
When to Use the Low Volume Mixer	83
When to Remove Damper and Mixer	84
Convert the Binary Pump to Low Delay Volume Mode	85
How to Optimize the Compressibility Compensation Setting	87
Solvent Compressibility Calibration	87
Optimization of Legacy Compressibility Settings	88

This chapter gives information on how to optimize the performance of the Binary Pump under special operational conditions.



When to Use a Vacuum Degasser

A degasser removes air, which is dissolved in any solvent. When solvents are heated or mixed with other solvents, air can leave the solvent and form small bubbles. Over time, these bubbles accumulate and can cause pressure fluctuations which may finally result in retention time shifts.

The G4225A High-performance Degasser and the G1322A Vacuum Degasser are external degassers that are designed to be used with Agilent 1260 Infinity binary pumps or 1100/1200 Series pumps. 1260 Infinity quaternary pumps, 1290 Infinity pumps, and 1120/1220 Infinity pumps have built-in degassers.

A degasser is needed for low pressure mixing pumps like Agilent quaternary pumps. High pressure mixing pumps like Agilent binary pumps are more robust with respect to bubble formation, but a degasser is recommended for best performance. Additionally, a degasser is highly recommended for the following applications:

- Your detector is used with maximum sensitivity in the low UV wavelength range.
- Your application requires highest injection precision.
- Your application requires highest retention-time reproducibility (flow rates below 0.5 mL/min).
- The binary pump is used with bypassed damper and mixer.

Operational Hints for the Vacuum Degasser

If you are using the vacuum degasser for the first time, if the vacuum degasser was switched off for any length of time (for example, overnight), or if the vacuum degasser chambers are empty, you have to prime the vacuum degasser before running an analysis. Priming is usually done by pumping at a high flow rate (3 – 5 mL/min). Alternatively, a syringe can be used to draw the solvent through the (empty) degasser if the pump does not aspirate the solvent by itself. For details see “[Initial Priming](#)” on page 54.

For more information see the Agilent 1260 Infinity Standard Degasser User Manual.

When to Use the Active Seal Wash Option

Concentrated buffer solutions will reduce the lifetime of the seals and pistons in your binary pump. The active seal wash option allows to maintain the seal lifetime by flushing the low pressure side of the seals with a wash solvent.

The seal wash option is strongly recommended if buffer concentrations of 0.1 M or higher are used regularly with the pump.

The active seal wash option kit can be ordered by quoting Active Seal Wash Upgrade Product including Service (G1399A).

The seal wash option comprises a peristaltic pump, secondary seals, gaskets, seal holders and tubing for both pump heads. A bottle of premixed water/isopropanol (90 /10 vol%) is placed in the solvent cabinet and connected to the peristaltic pump as described in the technical note that comes with the active seal wash kit.

Always use a mixture of HPLC-grade water (90 %) and isopropanol (10 %) as wash solvent. This mixture prevents bacteria growth in the wash bottle and reduces the surface tension of the water.

NOTE

In order to avoid accumulation of buffer salts or impurities, regularly replace the washing solution using fresh solvents.

The operation of the peristaltic pump can be controlled from the data system or the Instant Pilot.

For adding a seal-wash option, please contact your local Agilent Technologies service representative.

When to Use Alternative Seals

The standard seals for the binary pump can be used for most applications. However, normal phase applications (for example, hexane) are not compatible with the standard seals. They cause extremely high abrasion and significantly shorten seal life time.

For the use with normal phase applications special polyethylene pistons seals (yellow color, PE seals (pack of 2) (0905-1420)) are available. These seals have less abrasion compared to the standard seals.

WARNING

The seal wear-in procedure causes problems to the normal phase seals (yellow). They will be destroyed by the procedure.

→ DO NOT apply the seal wear-in procedure performed to normal phase seals.

- 1 Remove the standard seals from the pump head (“[Maintenance of a Pump Head without Seal Wash](#)” on page 159).
- 2 Install normal phase seals.

NOTE

Polyethylene seals have a limited pressure range of 0–200 bar. When used above 200 bar, their lifetime will be significantly reduced.

When to Use the Low Volume Mixer

The Low volume mixer (200 μ L) (5067-1565) is designed for use with the 1260 Infinity Binary LC System in low delay volume mode. This configuration is typically used for 2.1 mm i.d., 1.8 μ m particle size columns, where emphasis is put on S/N ratio. The low volume mixer helps mixing gradients starting with a low concentration of organic solvents, which can cause noise on the baseline. The maximum benefit of the mixer is achieved using the mixer together with FW revisions A.06.06 or higher.

The low volume mixer is installed with the corresponding holder (Low Volume Mixer Holder (G1312-00003)).

When to Remove Damper and Mixer

The binary pump is equipped with a pressure pulsation damper and a static mixer. The total delay volume of the pump is 600 – 800 μL (depending on system pressure). The mixer has a volume of 400 μL .

For applications that require lowest delay volume (e.g. fast gradient methods or gradient applications with low flow rates), damper and mixer can be bypassed.

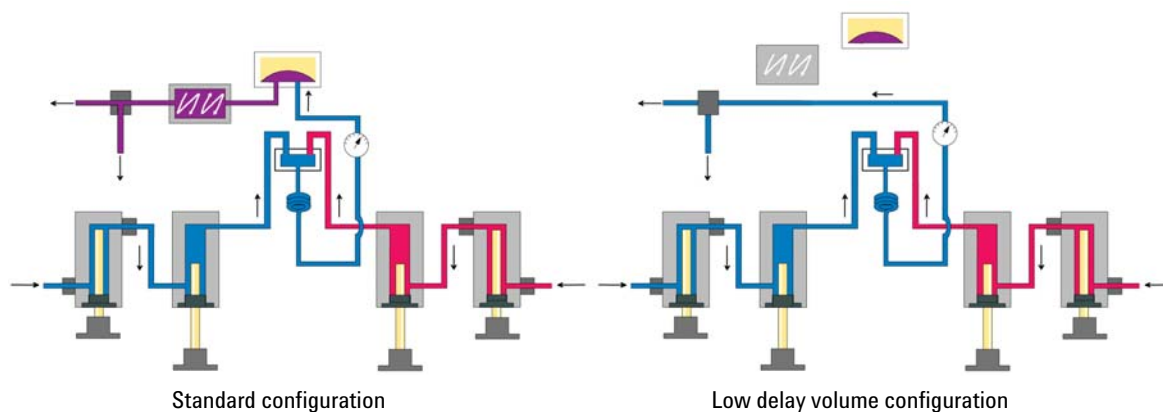

Figure 20 Flow Path Modifications of the Binary Pump

Convert the Binary Pump to Low Delay Volume Mode

The binary pump is delivered in standard configuration (damper and mixer connected). This paragraph shows how to bypass damper and mixer and convert the pump to low delay volume mode.

Configurations where only damper or mixer are disconnected while the other part is still in line are not supported by Agilent Technologies.

Tools required	p/n	Description
	8710-0510	Wrench, 1/4 - 5/16 inch, open
		Wrench, 14 mm
		Hex driver open, 1/4 inch

Preparations Flush the system (water if buffers were used, otherwise isopropanol).
Turn the flow off.

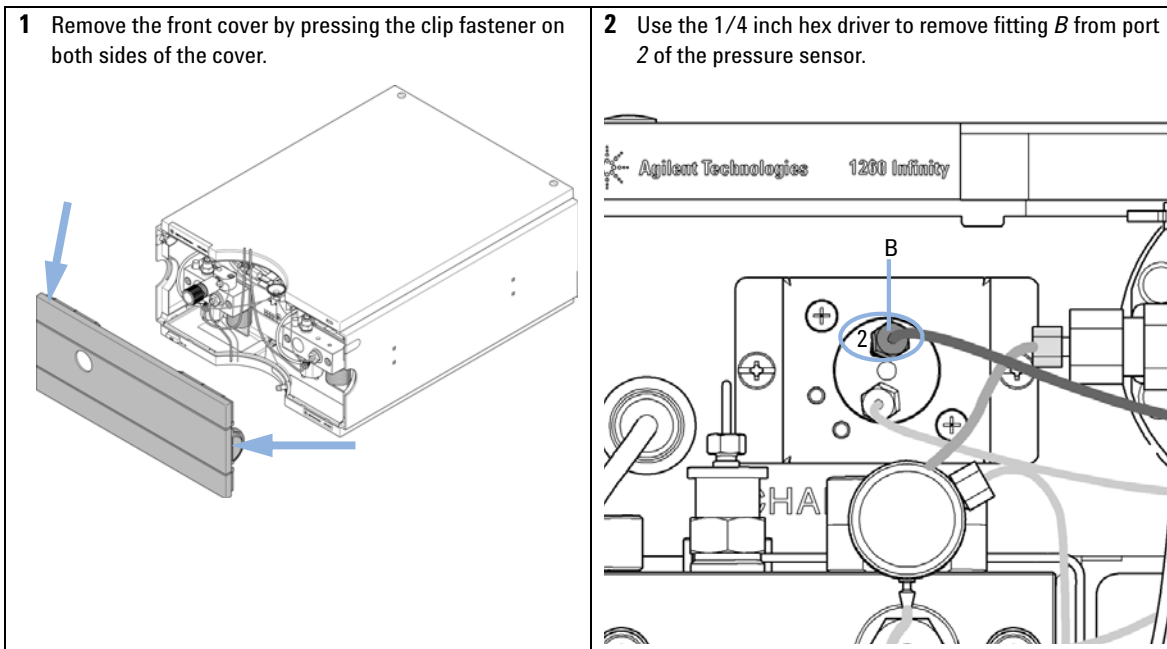

5 Optimizing Performance

When to Remove Damper and Mixer

- 3** Fold capillary end *B* away. It remains unconnected. Disconnect fitting *A* from outlet *1* of the mixer.

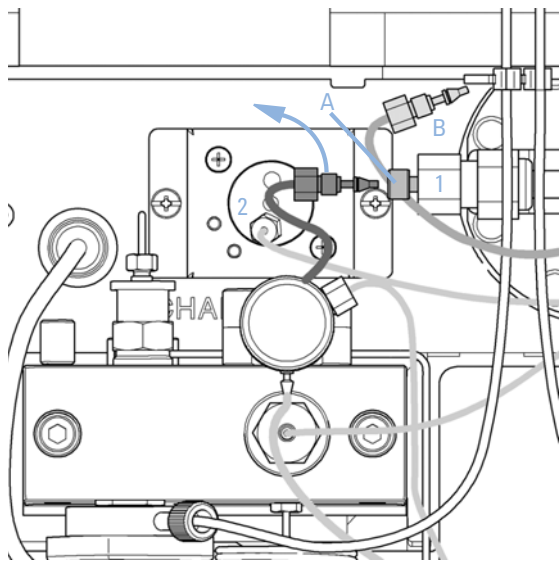

- 4** Connect fitting *A* to port 2 of the pressure sensor. Seal port 1 of the mixer with a plastic blank nut.

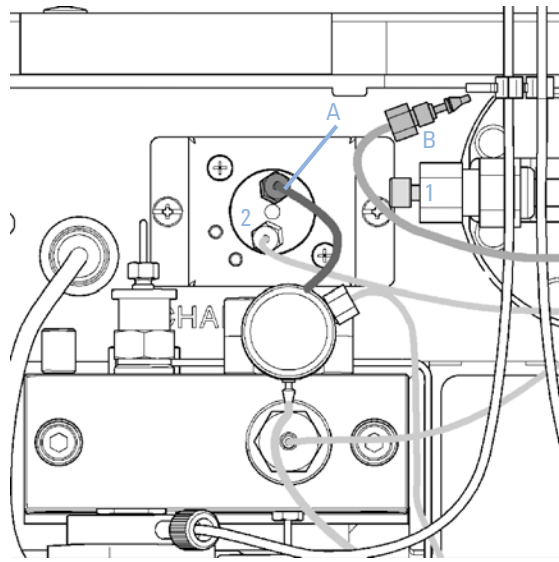

How to Optimize the Compressibility Compensation Setting

When a solvent is metered at ambient pressure and compressed to a higher pressure, the volume decreases depending on its compressibility. Solvent compressibility is a non-linear function of pressure and temperature. It is specific for each solvent.

In order to deliver the desired flow accurately at all pressures, Agilent pumps use a compressibility compensation. For standard LC applications, e.g. using a 400 bar binary pump, an average compressibility value for the solvent is sufficient.

For the 600 bar 1260 Infinity Binary Pump, the pressure-dependency of a solvent compressibility needs to be considered. It is determined at different pressures between 0 – 600 bar. The pump uses the obtained non-linear function to select the correct compressibility value for the actual pump pressure. Compressibility data for the most common solvents is readily available in the pump firmware.

The compensation algorithm is so powerful that the damper and mixer can be removed from the pump flow path at low flow rate while the pressure ripple and composition ripple remain at low levels.

For method compatibility reasons, the legacy compressibility compensation is still available.

Solvent Compressibility Calibration

Unlisted or premixed solvents can be calibrated with the Solvent Compressibility Calibration function. For a detailed description, see [“Binary Pump Solvent Compressibility Calibration”](#) on page 133.

Optimization of Legacy Compressibility Settings

The compressibility compensation default settings are 50×10^{-6} /bar (best for most aqueous solutions) for pump head A and 115×10^{-6} /bar (to suit organic solvents) for pump head B. The settings represent average values for aqueous solvents (A side) and organic solvents (B side). Therefore it is always recommended to use the aqueous solvent on the A side of the pump and the organic solvent on the B side. Under normal conditions, the default settings reduce the pressure pulsation to below 2 % of system pressure, which is sufficient for most applications. If the compressibility values for the solvents used differ from the default settings, it is recommended to change the compressibility values accordingly. Compressibility settings can be optimized by using the values for various solvents described in [Table 8](#) on page 89. If the solvent in use is not listed in the compressibility table, when using premixed solvents and if the default settings are not sufficient for your application, the following procedure can be used to optimize the compressibility settings:

- 1 Start channel A of the binary pump with the required flow rate.
- 2 Before starting the optimization procedure, the flow must be stable. Use degassed solvent only. Check the tightness of the system with the pressure test (see “(System) Pressure Test” on page 126).
- 3 Your pump must be connected to an Agilent data system or Instant Pilot, the pressure- and %-ripple can be monitored with one of these instruments, otherwise connect a signal cable between the pressure output of the isocratic pump and a recording device (for example, 339X integrator) and set following parameters.
Zero 50 % Att 2³ Chart Speed 10 cm/min
- 4 Start the recording device in plot mode.
- 5 Starting with a compressibility setting of 40×10^{-6} /bar, increase the value in steps of 10. Re-zero the integrator as required. The compressibility compensation setting that generates the smallest pressure ripple is the optimum value for your solvent composition.
- 6 Repeat step 1 through step 5 for the B channel of your binary pump.

Table 8 Solvent Compressibility

Solvent (pure)	Compressibility (10^{-6}/bar)
Acetone	126
Acetonitrile	115
Benzene	95
Carbon tetrachloride	110
Chloroform	100
Cyclohexane	118
Ethanol	114
Ethyl acetate	104
Heptane	120
Hexane	150
Isobutanol	100
Isopropanol	100
Methanol	120
1-Propanol	100
Toluene	87
Water	46

5 Optimizing Performance

How to Optimize the Compressibility Compensation Setting



6 Troubleshooting and Diagnostics

Overview of the Module's Indicators and Test Functions	92
Status Indicators	94
Power Supply Indicator	94
Module Status Indicator	95
User Interfaces	96
Agilent Lab Advisor Software	97

Overview of the troubleshooting and diagnostic features.



Overview of the Module's Indicators and Test Functions

Status Indicators

The module is provided with two status indicators which indicate the operational state (prerun, run, and error states) of the module. The status indicators provide a quick visual check of the operation of the module.

Error Messages

In the event of an electronic, mechanical or hydraulic failure, the module generates an error message in the user interface. For each message, a short description of the failure, a list of probable causes of the problem, and a list of suggested actions to fix the problem are provided (see chapter Error Information).

Test Functions

A series of test functions are available for troubleshooting and operational verification after exchanging internal components (see Tests and Calibrations).

Pressure Test

The **Pressure Test** is a quick test designed to determine the pressure tightness of the system (i.e. the high pressure flow path between pump and column). After exchanging flow path components (e.g. pump seals or injection seal), use this test to verify the system is pressure tight, see [“\(System\) Pressure Test”](#) on page 126.

Solvent Compressibility Calibration

Solvent compressibility is a function of solvent type and pressure. In order to optimize flow accuracy and pressure ripple, the compressibility of the solvent must be considered. The binary pump firmware contains compressibility parameters for most commonly used solvents. A compressibility calibration function is available to generate compressibility data for unlisted solvents (see [“Binary Pump Solvent Compressibility Calibration”](#) on page 133). The compressibility data are stored in an XML file and can be transferred to other G1312B pumps.

Pump Elasticity Calibration

Various parts in the flow path of the binary pump have a certain elasticity which needs to be compensated to obtain the lowest pressure-, flow- and composition ripple possible. This is done by running an elasticity calibration after maintenance and major repairs. For details see [“Pump Elasticity Calibration”](#) on page 135.

Leak Rate Test

The **Leak Rate Test** is a diagnostic test designed to determine the pressure tightness of the pump components. When a problem with the pump is suspected, use this test to help troubleshoot the pump and its pumping performance, see [“Leak Rate Test”](#) on page 137.

Diagnostic Signals

The pump has several signals (pressure, voltages and piston movement) that can be used for diagnosing pressure stability, composition and flow problems (see chapter Diagnostic Signals).

Status Indicators

Two status indicators are located on the front of the module. The lower left indicates the power supply status, the upper right indicates the module status.

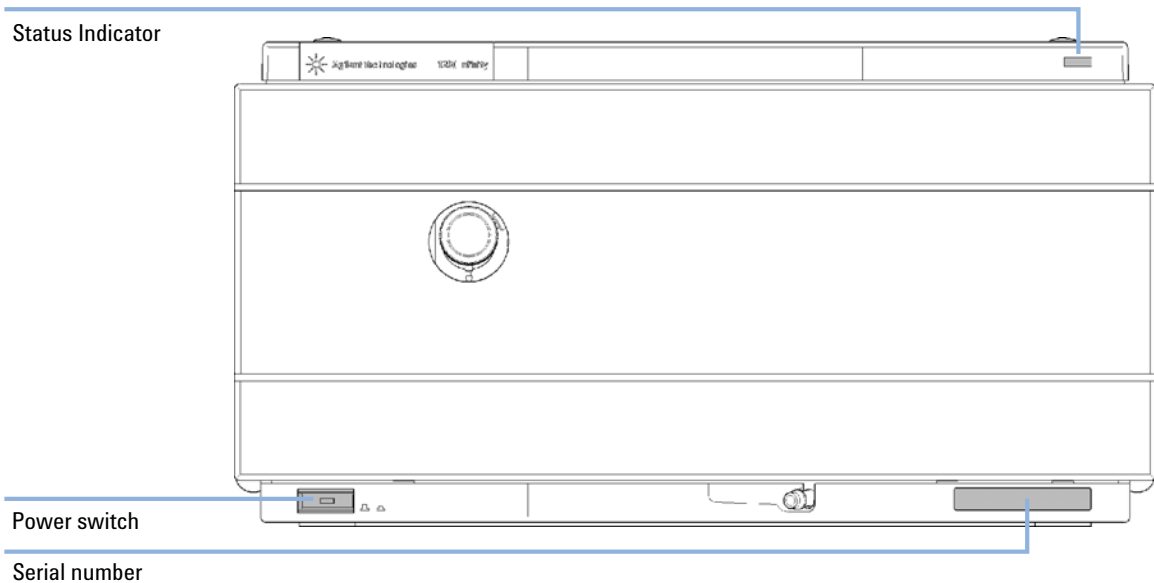

Figure 21 Location of Status Indicators

Power Supply Indicator

The power supply indicator is integrated into the main power switch. When the indicator is illuminated (*green*) the power is *ON*.

Module Status Indicator

The module status indicator indicates one of six possible module conditions:

- When the status indicator is *OFF* (and power switch light is on), the module is in a *prerun* condition, and is ready to begin an analysis.
- A *green* status indicator, indicates the module is performing an analysis (*run* mode).
- A *yellow* indicator indicates a *not-ready* condition. The module is in a not-ready state when it is waiting for a specific condition to be reached or completed (for example, immediately after changing a set point), or while a self-test procedure is running.
- An *error* condition is indicated when the status indicator is *red*. An error condition indicates the module has detected an internal problem which affects correct operation of the module. Usually, an error condition requires attention (e.g. leak, defective internal components). An error condition always interrupts the analysis.

If the error occurs during analysis, it is propagated within the LC system, i.e. a red LED may indicate a problem of a different module. Use the status display of your user interface for finding the root cause/module of the error.

- A *blinking* indicator indicates that the module is in resident mode (e.g. during update of main firmware).
- A *fast blinking* indicator indicates that the module is in a low-level error mode. In such a case try to re-boot the module or try a cold-start (see “[Special Settings](#)” on page 231. Then try a firmware update (see “[Replacing Module Firmware](#)” on page 181). If this does not help, a main board replacement is required.

User Interfaces

Depending on the user interface, the available tests vary. Some descriptions are only available in the Service Manual.

Test	Instant Pilot G4208A	Agilent Lab Advisor
Pressure Test	Yes	Yes
Valve Test	No	Yes
Solvent compressibility calibration	No	Yes
Pump elasticity calibration	No	Yes

Agilent Lab Advisor Software

The Agilent Lab Advisor software is a standalone product that can be used with or without data system. Agilent Lab Advisor software helps to manage the lab for high quality chromatographic results and can monitor in real time a single Agilent LC or all the Agilent GCs and LCs configured on the lab intranet.

Agilent Lab Advisor software provides diagnostic capabilities for all Agilent 1200 Infinity Series modules. This includes diagnostic capabilities, calibration procedures and maintenance routines for all the maintenance routines.

The Agilent Lab Advisor software also allows users to monitor the status of their LC instruments. The Early Maintenance Feedback (EMF) feature helps to carry out preventive maintenance. In addition, users can generate a status report for each individual LC instrument. The tests and diagnostic features as provided by the Agilent Lab Advisor software may differ from the descriptions in this manual. For details refer to the Agilent Lab Advisor software help files.

The Instrument Utilities is a basic version of the Lab Advisor with limited functionality required for installation, use and maintenance. No advanced repair, troubleshooting and monitoring functionality is included.

6 Troubleshooting and Diagnostics
Agilent Lab Advisor Software



7 Error Information

What Are Error Messages	101
General Error Messages	102
Timeout	102
Shutdown	103
Remote Timeout	104
Lost CAN Partner	104
Leak	105
Leak Sensor Open	105
Leak Sensor Short	106
Compensation Sensor Open	106
Compensation Sensor Short	107
Fan Failed	107
Open Cover	108
Module Error Messages	109
Solvent Zero Counter	109
Pressure Above Upper Limit	109
Pressure Below Lower Limit	110
Pressure Signal Missing	110
Valve Failed	111
Missing Pressure Reading	112
Wrong Pump Configuration	112
Electronic Fuse of SSV Open	113
AIV Fuse	113
Temperature Out of Range	114
Temperature Limit Exceeded	115
Motor-Drive Power	116
Encoder Missing	117
Inlet-Valve Missing	117



7 Error Information

Agilent Lab Advisor Software

Servo Restart Failed	118
Pump Head Missing	119
Index Limit	120
Index Adjustment	121
Index Missing	122
Stroke Length	122
Initialization Failed	123

This chapter describes the meaning of error messages, and provides information on probable causes and suggested actions how to recover from error conditions.

What Are Error Messages

Error messages are displayed in the user interface when an electronic, mechanical, or hydraulic (flow path) failure occurs which requires attention before the analysis can be continued (for example, repair, or exchange of consumables is necessary). In the event of such a failure, the red status indicator at the front of the module is switched on, and an entry is written into the module logbook.

If an error occurs outside a method run, other modules will not be informed about this error. If it occurs within a method run, all connected modules will get a notification, all LEDs get red and the run will be stopped. Depending on the module type, this stop is implemented differently. For example, for a pump the flow will be stopped for safety reasons. For a detector, the lamp will stay on in order to avoid equilibration time. Depending on the error type, the next run can only be started, if the error has been resolved, for example liquid from a leak has been dried. Errors for presumably single time events can be recovered by switching on the system in the user interface.

Special handling is done in case of a leak. As a leak is a potential safety issue and may have occurred at a different module from where it has been observed, a leak always causes a shutdown of all modules, even outside a method run.

In all cases, error propagation is done via the CAN bus or via an APG remote cable (see documentation for the APG interface).

General Error Messages

Timeout

Error ID: 0062

The timeout threshold was exceeded.

Probable cause

- 1** The analysis was completed successfully, and the timeout function switched off the module as requested.
- 2** A not-ready condition was present during a sequence or multiple-injection run for a period longer than the timeout threshold.

Suggested actions

- Check the logbook for the occurrence and source of a not-ready condition. Restart the analysis where required.
- Check the logbook for the occurrence and source of a not-ready condition. Restart the analysis where required.

Shutdown

Error ID: 0063

An external instrument has generated a shutdown signal on the remote line.

The module continually monitors the remote input connectors for status signals. A LOW signal input on pin 4 of the remote connector generates the error message.

Probable cause

- 1** Leak detected in another module with a CAN connection to the system.
- 2** Leak detected in an external instrument with a remote connection to the system.
- 3** Shut-down in an external instrument with a remote connection to the system.
- 4** The degasser failed to generate sufficient vacuum for solvent degassing.

Suggested actions

- Fix the leak in the external instrument before restarting the module.
- Fix the leak in the external instrument before restarting the module.
- Check external instruments for a shut-down condition.
- Check the vacuum degasser for an error condition. Refer to the *Service Manual* for the degasser or the 1260 pump that has the degasser built-in.

Remote Timeout

Error ID: 0070

A not-ready condition is still present on the remote input. When an analysis is started, the system expects all not-ready conditions (for example, a not-ready condition during detector balance) to switch to run conditions within one minute of starting the analysis. If a not-ready condition is still present on the remote line after one minute the error message is generated.

Probable cause

- 1 Not-ready condition in one of the instruments connected to the remote line.
- 2 Defective remote cable.
- 3 Defective components in the instrument showing the not-ready condition.

Suggested actions

- Ensure the instrument showing the not-ready condition is installed correctly, and is set up correctly for analysis.
- Exchange the remote cable.
- Check the instrument for defects (refer to the instrument's documentation).

Lost CAN Partner

Error ID: 0071

During an analysis, the internal synchronization or communication between one or more of the modules in the system has failed.

The system processors continually monitor the system configuration. If one or more of the modules is no longer recognized as being connected to the system, the error message is generated.

Probable cause

- 1 CAN cable disconnected.
- 2 Defective CAN cable.
- 3 Defective main board in another module.

Suggested actions

- Ensure all the CAN cables are connected correctly.
 - Ensure all CAN cables are installed correctly.
- Exchange the CAN cable.
- Switch off the system. Restart the system, and determine which module or modules are not recognized by the system.

Leak

Error ID: 0064

A leak was detected in the module.

The signals from the two temperature sensors (leak sensor and board-mounted temperature-compensation sensor) are used by the leak algorithm to determine whether a leak is present. When a leak occurs, the leak sensor is cooled by the solvent. This changes the resistance of the leak sensor which is sensed by the leak-sensor circuit on the main board.

Probable cause

- 1 Loose fittings.
- 2 Broken capillary.
- 3 Loose or leaking purge valve, active inlet valve, or outlet valve.
- 4 Defective pump seals.

Suggested actions

- Ensure all fittings are tight.
- Exchange defective capillaries.
- Ensure pump components are seated correctly. If there are still signs of a leak, exchange the appropriate seal (purge valve, active inlet valve, outlet valve).
- Exchange the pump seals.

Leak Sensor Open

Error ID: 0083

The leak sensor in the module has failed (open circuit).

The current through the leak sensor is dependent on temperature. A leak is detected when solvent cools the leak sensor, causing the leak-sensor current to change within defined limits. If the current falls outside the lower limit, the error message is generated.

Probable cause

- 1 Leak sensor not connected to the main board.
- 2 Defective leak sensor.
- 3 Leak sensor incorrectly routed, being pinched by a metal component.

Suggested actions

- Please contact your Agilent service representative.
- Please contact your Agilent service representative.
- Please contact your Agilent service representative.

Leak Sensor Short

Error ID: 0082

The leak sensor in the module has failed (short circuit).

The current through the leak sensor is dependent on temperature. A leak is detected when solvent cools the leak sensor, causing the leak sensor current to change within defined limits. If the current increases above the upper limit, the error message is generated.

Probable cause

- 1 Defective leak sensor.
- 2 Leak sensor incorrectly routed, being pinched by a metal component.

Suggested actions

- Please contact your Agilent service representative.
- Please contact your Agilent service representative.

Compensation Sensor Open

Error ID: 0081

The ambient-compensation sensor (NTC) on the main board in the module has failed (open circuit).

The resistance across the temperature compensation sensor (NTC) on the main board is dependent on ambient temperature. The change in resistance is used by the leak circuit to compensate for ambient temperature changes. If the resistance across the sensor increases above the upper limit, the error message is generated.

Probable cause

- 1 Defective main board.

Suggested actions

- Please contact your Agilent service representative.

Compensation Sensor Short

Error ID: 0080

The ambient-compensation sensor (NTC) on the main board in the module has failed (open circuit).

The resistance across the temperature compensation sensor (NTC) on the main board is dependent on ambient temperature. The change in resistance is used by the leak circuit to compensate for ambient temperature changes. If the resistance across the sensor falls below the lower limit, the error message is generated.

Probable cause

- 1 Defective main board.

Suggested actions

Please contact your Agilent service representative.

Fan Failed

Error ID: 0068

The cooling fan in the module has failed.

The hall sensor on the fan shaft is used by the main board to monitor the fan speed. If the fan speed falls below a certain limit for a certain length of time, the error message is generated.

This limit is given by 2 revolutions/second for longer than 5 seconds.

Depending on the module, assemblies (e.g. the lamp in the detector) are turned off to assure that the module does not overheat inside.

Probable cause

- 1 Fan cable disconnected.
- 2 Defective fan.
- 3 Defective main board.
- 4 Improperly positioned cables or wires obstructing fan blades.

Suggested actions

Please contact your Agilent service representative.

Please contact your Agilent service representative.

Please contact your Agilent service representative.

Please contact your Agilent service representative.

Open Cover

Error ID: 0205

The top foam has been removed.

The sensor on the main board detects when the top foam is in place. If the foam is removed, the fan is switched off, and the error message is generated.

Probable cause

- 1** The top foam was removed during operation.
- 2** Foam not activating the sensor.
- 3** Defective sensor or main board.
- 4** Rear of the module is exposed to strong direct sunlight.

Suggested actions

- Please contact your Agilent service representative.
- Please contact your Agilent service representative.
- Please contact your Agilent service representative.
- Ensure that the rear of module is not directly exposed to strong sunlight.

Module Error Messages

Solvent Zero Counter

Error ID: 2055

The error message is triggered if the remaining volume in a solvent bottle falls below the set limit.

Probable cause

- 1 Volume in bottle below specified volume.
- 2 Incorrect setting.

Suggested actions

- Refill bottles and reset solvent counters.
- Make sure the set solvent volume matches the actual bottle filling and set the shutoff limit to a reasonable value (e.g. 100 mL for 1 L bottles)

Pressure Above Upper Limit

Error ID: 2014, 2500

The system pressure has exceeded the upper pressure limit.

Probable cause

- 1 Upper pressure limit set too low.
- 2 Blockage in the flowpath (after the damper).
- 3 Defective damper.
- 4 Defective main board.

Suggested actions

- Ensure the upper pressure limit is set to a value suitable for the analysis.
- Check for blockage in the flowpath. The following components are particularly subject to blockage: inline filter frit, needle (autosampler), seat capillary (autosampler), sample loop (autosampler), column frits and capillaries with small internal diameters (e.g. 50 µm ID).
- Please contact your Agilent service representative.
- Please contact your Agilent service representative.

Pressure Below Lower Limit

Error ID: 2015, 2501

The system pressure has fallen below the lower pressure limit.

Probable cause

- 1 Lower pressure limit set too high.
- 2 Air bubbles in the mobile phase.
- 3 Leak.
- 4 Defective damper.
- 5 Defective main board.

Suggested actions

Ensure the lower pressure limit is set to a value suitable for the analysis.

- Make sure that the degasser is in flow path and works correctly. Purge the module.
- Ensure solvent inlet filters are not blocked.
- Inspect the pump head, capillaries and fittings for signs of a leak.
- Purge the module. Run a pressure test to determine whether the seals or other module components are defective.

Please contact your Agilent service representative.

Please contact your Agilent service representative.

Pressure Signal Missing

Error ID: 2016

The pressure signal of the damper is missing.

The pressure signal of the damper must be within a specific voltage range. If the pressure signal is missing, the processor detects a voltage of approximately -120 mV across the damper connector.

Probable cause

- 1 Damper disconnected.
- 2 Defective damper.

Suggested actions

Please contact your Agilent service representative.

Please contact your Agilent service representative.

Valve Failed

Error ID: 2040

Valve 0 Failed: valve A1

Valve 1 Failed: valve A2

Valve 2 Failed: valve B2

Valve 3 Failed: valve B1

One of the solvent selection valves in the module failed to switch correctly.

The processor monitors the valve voltage before and after each switching cycle. If the voltages are outside expected limits, the error message is generated.

Probable cause

- 1** Solvent selection valve disconnected.
- 2** Connection cable (inside instrument) not connected.
- 3** Connection cable (inside instrument) defective.
- 4** Solvent selection valve defective.

Suggested actions

- Please contact your Agilent service representative.
- Please contact your Agilent service representative.
- Please contact your Agilent service representative.
- Exchange the solvent selection valve.

Missing Pressure Reading

Error ID: 2054

The pressure readings read by the pump ADC (analog-digital converter) are missing.

The ADC reads the pressure signal of from the damper every 1ms. If the readings are missing for longer than 10 s, the error message is generated.

Probable cause

- 1 Damper disconnected.
- 2 Defective damper.
- 3 Defective main board.

Suggested actions

- Please contact your Agilent service representative.
- Please contact your Agilent service representative.
- Please contact your Agilent service representative.

Wrong Pump Configuration

Error ID: 2060

At switch-on, the pump has recognized a new pump configuration.

The binary pump is assigned its configuration at the factory. If the active inlet valve and pump encoder of channel B are disconnected, and the binary pump is rebooted, the error message is generated.

Probable cause

- 1 Active-inlet valve and pump encoder of channel B disconnected.

Suggested actions

- Please contact your Agilent service representative.

Electronic Fuse of SSV Open

Error ID: 2049

Valve Fuse 0: Channels A1 and A2

Valve Fuse 1: Channels B1 and B2

One of the solvent-selection valves in the module has drawn excessive current causing the selection-valve electronic fuse to open.

Probable cause

- 1 Defective solvent selection valve.
- 2 Defective connection cable (front panel to main board).
- 3 Defective main board.

Suggested actions

- Restart the pump. If the error message appears again, exchange the solvent selection valve.
- Please contact your Agilent service representative.
- Please contact your Agilent service representative.

AIV Fuse

Error ID: 2044

Inlet-Valve Fuse 0: Pump channel A

Inlet-Valve Fuse 1: Pump channel B

One of the active-inlet valves in the module has drawn excessive current causing the inlet-valve electronic fuse to open.

Probable cause

- 1 Defective active inlet valve.
- 2 Defective connection cable (front panel to main board).
- 3 Defective main board.

Suggested actions

- Restart the module. If the error message appears again, exchange the active inlet valve.
- Please contact your Agilent service representative.
- Please contact your Agilent service representative.

Temperature Out of Range

Error ID: 2517

Temperature Out of Range 0: Pump channel A

Temperature Out of Range 1: Pump channel B

One of the temperature sensor readings in the motor-drive circuit are out of range.

The values supplied to the ADC by the hybrid sensors must be between 0.5 V and 4.3 V. If the values are outside this range, the error message is generated.

Probable cause

- 1 Defective main board.

Suggested actions

Please contact your Agilent service representative.

Temperature Limit Exceeded

Error ID: 2517

Temperature Limit Exceeded 0: Pump channel A

Temperature Limit Exceeded 1: Pump channel B

The temperature of one of the motor-drive circuits is too high.

The processor continually monitors the temperature of the drive circuits on the main board. If excessive current is being drawn for long periods, the temperature of the circuits increases. If the temperature exceeds the upper limit, the error message is generated.

Probable cause

- 1** High friction (partial mechanical blockage) in the pump drive assembly.
- 2** Partial blockage of the flowpath in front of the damper.
- 3** Defective pump drive assembly.
- 4** Defective main board.

Suggested actions

- Remove the pump-head assembly. Ensure there is no mechanical blockage of the pump-head assembly or pump drive assembly.
- Ensure the outlet valve is not blocked.
- Please contact your Agilent service representative.
- Please contact your Agilent service representative.

Motor-Drive Power

Error ID: 2041, 2042

Motor-Drive Power: Pump channel A

B: Motor-Drive Power: Pump channel B

The current drawn by the pump motor exceeded the maximum limit.

Blockages in the flow path are usually detected by the pressure sensor in the damper, which result in the pump switching off when the upper pressure limit is exceeded. If a blockage occurs before the damper, the pressure increase cannot be detected by the pressure sensor and the module will continue to pump. As pressure increases, the pump drive draws more current. When the current reaches the maximum limit, the module is switched off, and the error message is generated.

Probable cause

- 1 Flow path blockage in front of the damper.
- 2 Blocked active inlet valve.
- 3 Blocked outlet valve.
- 4 High friction (partial mechanical blockage) in the pump drive assembly.
- 5 Defective pump drive assembly.
- 6 Defective main board.
- 7 Restriction capillary blocked at pre-mixing union.

Suggested actions

- Ensure the capillaries and frits between the pump head and damper inlet are free from blockage.
- Exchange the active inlet valve.
- Exchange the outlet valve.
- Remove the pump-head assembly. Ensure there is no mechanical blockage of the pump-head assembly or pump drive assembly.
- Please contact your Agilent service representative.
- Please contact your Agilent service representative.
- Exchange restriction capillary.

Encoder Missing

Error ID: 2046, 2050, 2510

Encoder Missing: Pump channel A

B: Encoder Missing: Pump channel B

The optical encoder on the pump motor in the module is missing or defective.

The processor checks the presence of the pump encoder connector every 2 s. If the connector is not detected by the processor, the error message is generated.

Probable cause

- 1 Defective or disconnected pump encoder connector.
- 2 Defective pump drive assembly.

Suggested actions

- Please contact your Agilent service representative.
- Please contact your Agilent service representative.

Inlet-Valve Missing

Error ID: 2048, 2052

Inlet-Valve Missing: Pump channel A

B: Inlet-Valve Missing: Pump channel B

The active-inlet valve in the module is missing or defective.

The processor checks the presence of the active-inlet valve connector every 2 s. If the connector is not detected by the processor, the error message is generated.

Probable cause

- 1 Disconnected or defective cable.
- 2 Disconnected or defective connection cable (front panel to main board).
- 3 Defective active inlet valve.

Suggested actions

- Ensure the pins of the active inlet valve connector are not damaged. Ensure the connector is seated securely.
- Please contact your Agilent service representative.
- Exchange the active inlet valve.

Servo Restart Failed

Error ID: 2201, 2211

Servo Restart Failed: Pump channel A

B: Servo Restart Failed: Pump channel B

The pump motor in the module was unable to move into the correct position for restarting.

When the module is switched on, the first step is to switch on the C phase of the variable reluctance motor. The rotor should move to one of the C positions. The C position is required for the servo to be able to take control of the phase sequencing with the commutator. If the rotor is unable to move, or if the C position cannot be reached, the error message is generated.

Probable cause

- 1 Disconnected or defective cable.
- 2 Blocked active inlet valve.
- 3 Mechanical blockage of the module.
- 4 Defective pump drive assembly.
- 5 Defective main board.

Suggested actions

- Please contact your Agilent service representative.
- Exchange the active inlet valve.
- Remove the pump-head assembly. Ensure there is no mechanical blockage of the pump-head assembly or pump drive assembly.
- Please contact your Agilent service representative.
- Please contact your Agilent service representative.

Pump Head Missing

Error ID: 2202, 2212

Pump Head Missing: Pump channel A

B: Pump Head Missing: Pump channel B

The pump-head end stop in the pump was not found.

When the pump restarts, the metering drive moves forward to the mechanical end stop. Normally, the end stop is reached within 20 s, indicated by an increase in motor current. If the end point is not found within 20 s, the error message is generated.

Probable cause

- 1 Pump head not installed correctly (screws not secured, or pump head not seated correctly).
- 2 Broken piston.

Suggested actions

- Install the pump head correctly. Ensure nothing (e.g. capillary) is trapped between the pump head and body.
- Exchange the piston.

Index Limit

Error ID: 2203, 2213

Index Limit: Pump channel A

B: Index Limit: Pump channel B

The time required by the piston to reach the encoder index position was too short (pump).

During initialization, the first piston is moved to the mechanical stop. After reaching the mechanical stop, the piston reverses direction until the encoder index position is reached. If the index position is reached too fast, the error message is generated.

Probable cause

- 1 Irregular or sticking drive movement.
- 2 Defective pump drive assembly.

Suggested actions

Remove the pump head, and examine the seals, pistons, and internal components for signs of wear, contamination or damage. Exchange components as required.

Please contact your Agilent service representative.

Index Adjustment

Error ID: 2204, 2214

Index Adjustment: Pump channel A

B: Index Adjustment: Pump channel B

The encoder index position in the module is out of adjustment.

During initialization, the first piston is moved to the mechanical stop. After reaching the mechanical stop, the piston reverses direction until the encoder index position is reached. If the time to reach the index position is too long, the error message is generated.

Probable cause

- 1 Irregular or sticking drive movement.
- 2 Defective pump drive assembly.

Suggested actions

Remove the pump head, and examine the seals, pistons, and internal components for signs of wear, contamination or damage. Exchange components as required.

Please contact your Agilent service representative.

Index Missing

Error ID: 2205, 2215, 2505

Index Missing: Pump channel A

B: Index Missing: Pump channel B

The encoder index position in the module was not found during initialization.

During initialization, the first piston is moved to the mechanical stop. After reaching the mechanical stop, the piston reverses direction until the encoder index position is reached. If the index position is not recognized within a defined time, the error message is generated.

Probable cause

- 1 Disconnected or defective encoder cable.
- 2 Defective pump drive assembly.

Suggested actions

- Please contact your Agilent service representative.
- Please contact your Agilent service representative.

Stroke Length

Error ID: 2206, 2216

Stroke Length: Pump channel A

B: Stroke Length: Pump channel B

The distance between the lower piston position and the upper mechanical stop is out of limits (pump).

During initialization, the module monitors the drive current. If the piston reaches the upper mechanical stop position before expected, the motor current increases as the module attempts to drive the piston beyond the mechanical stop. This current increase causes the error message to be generated.

Probable cause

- 1 Defective pump drive assembly.

Suggested actions

- Please contact your Agilent service representative.

Initialization Failed

Error ID: 2207, 2217

Initialization Failed: Pump channel A

B: Initialization Failed: Pump channel B

The module failed to initialize successfully within the maximum time window.

A maximum time is assigned for the complete pump-initialization cycle. If the time is exceeded before initialization is complete, the error message is generated.

Probable cause

- 1 Blocked active inlet valve.
- 2 Defective pump drive assembly.
- 3 Defective main board.

Suggested actions

- Exchange the active inlet valve.
- Please contact your Agilent service representative.
- Please contact your Agilent service representative.

7 Error Information

Module Error Messages



8 Test Functions and Calibration

(System) Pressure Test	126
Positioning the Blank Nut	127
Running the (System) Pressure Test	128
Evaluating the Results	129
Valve Test	131
Running the Valve Test	132
Evaluating the Results	132
Binary Pump Solvent Compressibility Calibration	133
Running the Solvent Compressibility Calibration	134
Pump Elasticity Calibration	135
Running the Pump Elasticity Calibration	136
Leak Rate Test	137
Running the Test	139
Evaluating the Results	140
Potential Causes of Leak Rate Test Failure	141

This chapter explains all test functions that are available for the binary pump.



(System) Pressure Test

NOTE

This Lab Advisor test uses different names depending on the firmware revision used:

- FW revision \geq A.06.50: **System Pressure Test**
 - FW revision $<$ A.05.60: **Pressure Test**
-

Description

The (system) pressure test is a quick built-in test designed to demonstrate the leak tightness of the system. The test involves monitoring the flow profile while the pump delivers against a blank nut. The result is presented as the leak rate of the module and provides information about the leak tightness of the system between the outlet valves of the pump and the blank nut.

NOTE

The blank nut can be positioned anywhere between the purge valve of the pump and the detector inlet to pressure test the desired part of the system.

CAUTION

Blank nut placed at the outlet of flow cell

The applied pressure may cause permanent leaks or bursting of the flow cell.

→ Never include the flow cell in the pressure test.

Step 1

The test begins with the initialization of both pump heads. After initialization, the pump is starting the compression phase and the required flow rate is constantly monitored and adjusted. The pump continues to pump until a system pressure of around 600 bar is reached.

Step 2

When the system pressure reaches 600 bar, the pump continues to pump at a flow rate that keeps the pressure constant. The flow that is needed to keep the pressure constant is directly translated into a leak rate.

Positioning the Blank Nut

To test the complete system's pressure tightness, the blank nut should be positioned at the column compartment outlet (or the outlet of the last module before the detector).

If a specific component is suspected of causing a system leak, place the blank nut immediately before the suspected component, and then run the **(System) Pressure Test** again. If the test passes, the defective component is located after the blank nut. Confirm the diagnosis by placing the blank nut immediately after the suspected component. The diagnosis is confirmed if the test fails.

Running the (System) Pressure Test

Running the test from the Agilent Lab Advisor

When The test should be used when problems with small leaks are suspected, or after maintenance of flow path components (e.g., pump seals, injection seal) to prove pressure tightness up to 600 bar

Tools required	p/n	Description
	8710-0510	Wrench, 1/4 - 5/16 inch, open Blank nut 1/16 inch

Preparations Place two bottles of HPLC-grade water in channels A and B (A1 and B1 if the pump is equipped with a solvent selection valve)

NOTE

Make absolutely sure that all parts of the flow path that are part of the test are very thoroughly flushed with water before starting to pressurize the system! Any trace of other solvents or the smallest air bubble inside the flow path definitely will cause the test to fail!

- 1 Select the (system) pressure test from the test selection menu.
- 2 Start the test and follow the instructions.

NOTE

Make sure to release the pressure by opening the purge valve when the test has completed. Otherwise the pump may generate an overpressure error.

Evaluating the Results

The sum of all leaks between the pump and the blank nut will add up to the total leak rate. Note that small leaks may cause the test to fail, but solvent may not be seen leaking from a module.

NOTE

Please notice the difference between an *error* in the test and a *failure* of the test! An *error* is caused by the abnormal termination during the operation of the test whereas a *failure* of a test indicates that the test results were not within the specified limits.

If the pressure test fails:

- Ensure all fittings between the pump and the blank nut are tight. Repeat the pressure test.

NOTE

Often it is only a damaged blank nut itself (poorly shaped from overtightening) that causes the test to fail. Before investigating on any other possible sources of failure make sure that the blank nut you are using is in good condition and properly tightened!

- If the test fails again, insert the blank nut at the outlet of the previous module in the stack (e.g. autosampler, port 6 of the injection valve), and repeat the pressure test. Exclude each module one by one to determine which module is leaking.
- If the pump is determined to be the source of the leak, run the valve test to identify the defective pump component.

Potential Causes of Pressure Test Failure

After isolating and fixing the cause of the leak, repeat the pressure test to confirm the system is pressure tight.

Table 9 Potential Cause (Pump)

Potential Cause (Pump)	Corrective Action
Purge valve open.	Close the purge valve.
Loose or leaky fitting.	Tighten the fitting or exchange the capillary.
Damaged pump seals or pistons.	Run the valve test to identify the defective component.
Loose purge valve.	Tighten the purge valve nut (14 mm wrench).

Table 10 Potential Cause (Autosampler)

Potential Cause (Autosampler)	Corrective Action
Loose or leaky fitting.	Tighten or exchange the fitting or capillary.
Rotor seal (injection valve).	Exchange the rotor seal.
Damaged metering seal or piston.	Exchange the metering seal. Check the piston for scratches. Exchange the piston if required.
Needle seat.	Exchange the needle seat.

Table 11 Potential Cause (Column Compartment)

Potential Cause (Column Compartment)	Corrective Action
Loose or leaky fitting.	Tighten or exchange the fitting or capillary.
Rotor seal (column switching valve).	Exchange the rotor seal.

Valve Test

Description

The **Valve Test** provides a fast and accurate way to verify proper hydraulic operation of the binary pump. Problems that are related to defective valves, seals or pistons can be diagnosed and usually the defective part is identified.

NOTE

If a minimum firmware of A.06.50 is installed on this module and a minimum Lab Advisor revision of B.02.03. is available, please run the improved **Leak Rate Test** instead (see “[Leak Rate Test](#)” on page 137).

Step 1

The system is setup with water on both channels and a restriction capillary is attached to the outlet of the pump. Pump head A is delivering at 1 mL/min. The pressure signal is monitored and overlaid with the piston movement plot. The pressure pattern and the slope of the pressure signal are evaluated for the delivery strokes of both pistons.

Step 2

The procedure from step 1 is repeated on pump head B.

Step 3

The data from step 1 and 2 are evaluated. In case test failed, a conclusion about the defective part is made.

Running the Valve Test

Running the test from the Agilent Lab Advisor

- When**
- For FW revisions < A.06.50
 - The test should be used to prove proper operation of the binary pump after repairs or when the pressure test (see “(System) Pressure Test” on page 126) determined a problem with the pump.

Tools required

p/n	Description
8710-0510	Wrench, 1/4 - 5/16 inch, open

Parts required

p/n	Description
G1312-67500	Calibration capillary assembly

Preparations Place two bottles of HPLC-grade water in channels A and B (A1 and B1 if the pump is equipped with a solvent selection valve)

NOTE

The **Valve Test** should only be performed when firmware revisions < A.06.50 are installed. For firmware revision A.06.50 or above, perform the **Leak Rate Test** instead.

NOTE

Make absolutely sure that the pump is very thoroughly flushed with water before starting the test! Any trace of other solvents or the smallest air bubble inside the flow path definitely will cause the test to generate misleading results!

- 1 Select the valve test from the test selection menu.
- 2 Start the test and follow the instructions.

NOTE

Make sure to release the pressure by opening the purge valve when the test has completed. Otherwise the pump may generate an overpressure error.

Evaluating the Results

Refer to the help file of the Agilent Lab Advisor for further details.

Binary Pump Solvent Compressibility Calibration

Description

Each solvent or solvent mixture has unique compressibility at different pressures. In order to deliver accurate flow with minimal pressure- and composition ripple over the full operational pressure range, it is necessary that the pump compensates precisely for the compressibility of the solvents in use.

The binary pump comes with compressibility parameters for the most common HPLC solvents and solvent mixtures. If a solvent is not available in the list of pre-calibrated solvents, the solvent compressibility calibration allows the appropriate compressibility data to be generated.

Technical background

The solvent compressibility calibration relies on an accurate elasticity calibration of the pump. With a proper elasticity calibration in place, the pump is switched into pressure control mode. A restriction capillary is connected to the purge valve outlet. By varying the flow rate, the pump maintains a certain pressure. The pump optimizes the compressibility value of the solvent until the lowest possible pump ripple is reached. The pump increases the flow rate and adjusts the pressure to the next calibration step where the pump ripple is minimized again. This process is repeated until solvent compressibility data for the whole operating pressure range of the pump are available.

The compressibility data set for this solvent is stored in an XML-file in C:\Documents and Settings\\Application Data\Agilent Technologies\Agilent Lab Advisor\2.02.0.0\data\. It can be shared with other G1312B pumps via the controlling data system.

Running the Solvent Compressibility Calibration

Running the Solvent Compressibility Calibration from the Agilent Lab Advisor

When	If a solvent is not available in the list of pre-calibrated solvents, the solvent compressibility calibration allows to generate appropriate compressibility data.	
Tools required	p/n	Description
	8710-0510	Wrench, 1/4 - 5/16 inch, open
Parts required	p/n	Description
	G1312-67500	Calibration capillary assembly
Preparations	Place a bottles with solvent to be calibrated in channel A (resp. A1 if a solvent selection valve is installed).	

CAUTION

Avoid inaccurate pump elasticity calibration.

This would lead into invalid and not-portable solvent compressibility data.

→ Make sure to perform accurate pump elasticity calibration.

NOTE

Make absolutely sure that the pump is very thoroughly flushed with the solvent to be calibrated before starting the procedure! Any trace of other solvents or the smallest air bubble inside the flow path definitely will cause the calibration to fail!

- 1 Select the solvent from the test selection menu.
- 2 Start the test and follow the instructions.

NOTE

Make sure to release the pressure by opening the purge valve when the test has completed. Otherwise the pump may generate an overpressure error.

Pump Elasticity Calibration

Description

The flow path components of the binary pump have an inherent and pressure dependent elasticity which differs from pump to pump. When this elasticity/pressure function is known, a correction algorithm can be applied. This results in significantly improved pump performance in low delay volume mode (damper and mixer bypassed).

The pump elasticity calibration uses a solvent with well known properties (HPLC-grade water) to determine the pump elasticity over the entire operating pressure range and stores the calibration values in the non-volatile RAM of the pump mainboard.

The initial calibration is done at the factory. It only needs to be repeated after replacement of major pump parts (mainboard, pump drive). The test allows to define which pump head will be calibrated.

NOTE

Results of the pump elasticity calibration rely on known compressibility parameters for pure water. If the water is not HPLC-grade, not well degassed or degasser and pump are not flushed properly, the pump elasticity calibration will fail. The pump elasticity calibration has to be performed for each pump head individually.

CAUTION

Incorrect pump elasticity calibration.

Solvent compressibility calibrations acquired with a miscalibrated pump will work, but they are not transferable to other pumps. A correct pump elasticity calibration is an essential prerequisite for successful solvent compressibility calibrations.

→ Calibrate the pump elasticity correctly.

Running the Pump Elasticity Calibration

Running the Pump Elasticity Calibration from the Agilent Lab Advisor Software

When The initial calibration is done at the factory. It only needs to be repeated after replacement of major pump parts (mainboard, pump drive).

Tools required	p/n	Description
	8710-0510	Wrench, 1/4 - 5/16 inch, open

Parts required	p/n	Description
	G1312-67500	Calibration capillary assembly

Preparations Place all bottle heads in to a bottle of HPLC-grade water.

NOTE

Make absolutely sure that the pump is very thoroughly flushed with the solvent to be calibrated before starting the procedure! Any trace of other solvents or the smallest air bubble inside the flow path definitely will cause the calibration to fail!

NOTE

If a solvent selection valve is installed flush all four solvent channels to avoid that air from a dry solvent intake tube is drawn into the flow path upon initialization.

- 1 Select the pump elasticity calibration from the test selection menu.
- 2 Start the test and follow the instructions.

NOTE

Make sure to release the pressure by opening the purge valve when the test has completed. Otherwise the pump may generate an overpressure error.

Leak Rate Test

Introduction

The **Leak Rate Test** is used for verifying the internal tightness of the pump and helps identifying parts which may have caused a leak.

System requirements

Minimum software revisions:

- Lab Advisor B.02.03

Minimum firmware revisions:

- A.06.50

NOTE

This test does not work in emulation mode, that is when the G1312B Binary Pump emulates the G1312A Binary Pump. In case of an emulated module, convert to the original type first (see [“Replacing Module Firmware”](#) on page 181).

Test Principle

A solvent can be chosen from available solvent channels and a maximum target pressure can be defined at which the test will be run. Typically, this is the maximum pressure specified for the pump. The test can be run with any solvent compatible to the pump.

Before the test, the pump is flushed with solvent in order to remove air bubbles, as air bubbles are compressed during the test and therefore would appear as leaks. Using a degasser is highly recommended.

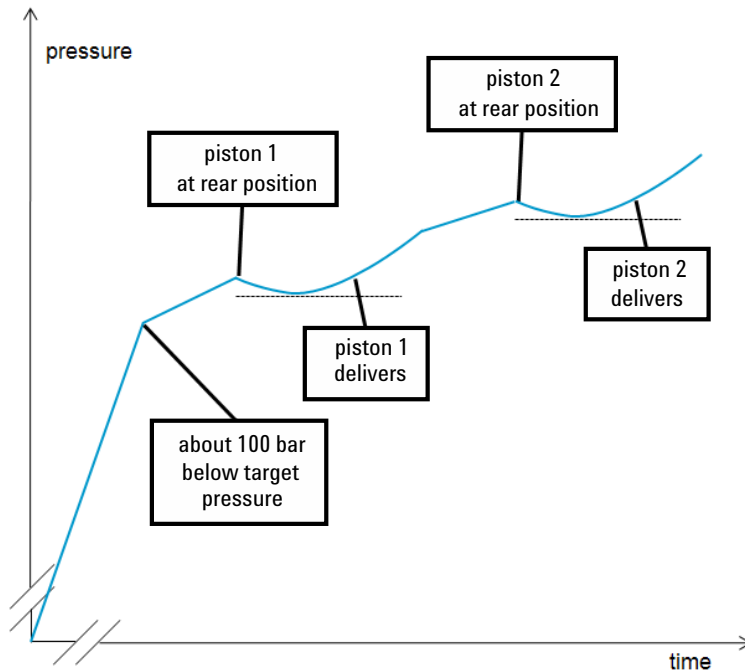

Initially, the pressure is increased to about 100 bar below the target pressure, which has been set for the test.

Then piston 1 is brought to its rear position. An increasing flow is delivered by piston 1. In case of a leak, the pressure will drop initially as long as the flow rate delivered by the piston is lower than the leak rate. As soon as the flow rate of the piston exceeds the leak rate, the measured pressure will increase again. Therefore the minimum pressure of that

curve segment corresponds to the flow and leak rate at that time and the leak rate is measured.

Subsequently, piston 2 is moved to its rear position, then piston 2 delivers and the measurement is done as described for piston 1.

For a binary pump (G1312B/C, K1312B), the test is run for both pump heads for channels A and B.

Running the Test

Parts required	p/n	Description
	01080-83202	Blank nut

Running the test from the Agilent Lab Advisor

- 1 Select the **Leak Rate Test** from the **Test Selection** menu.
- 2 Start the test and follow the instructions.

NOTE

Make sure to release the pressure by slowly opening the purge valve when the test has finished.

Evaluating the Results

Results of the leak rate test are the leak rates measured for pistons 1 and 2 as described for the test principle. If any of the leak rates exceeds $3 \mu\text{L}/\text{min}$, the test will fail.

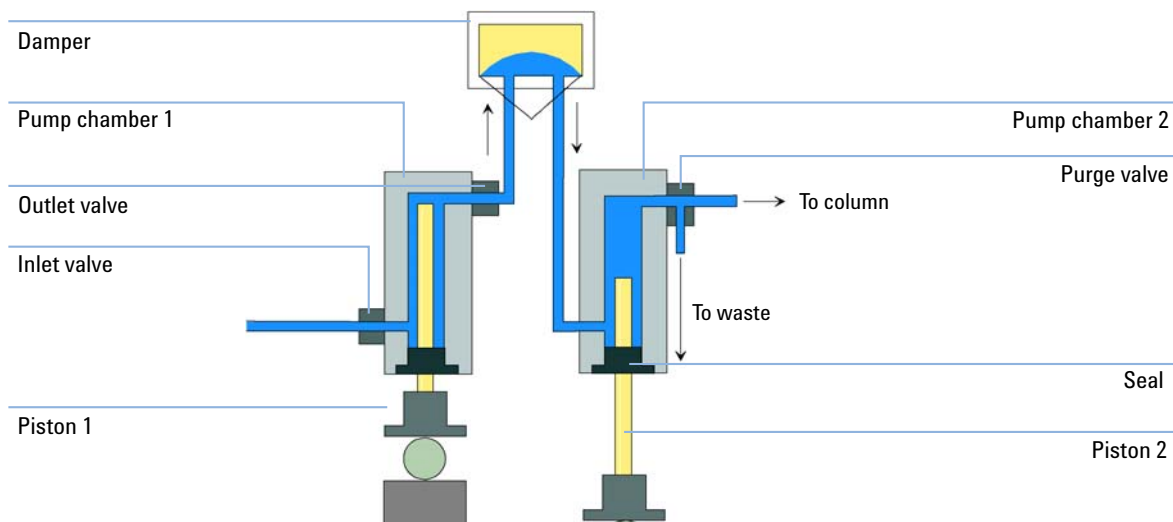

Potential Causes of Leak Rate Test Failure

NOTE

For binary pumps, secondary pump chambers are connected. A leak observed in any of these chambers may be caused by the other secondary pump chamber.

Secondary Leak

If a leak is found for movement of piston 2 (secondary leak), the following reasons are possible:

Probable cause	Suggested actions
1 System not flushed properly	Flush system for several minutes
2 Degassing efficiency is low	Check degasser performance
3 Purge valve not closed or defect	Check purge valve
4 Blank nut not installed tightly	Tighten or replace blank nut
5 Outlet valve leaking (read below)	Replace outlet valve
6 Leak at piston 2 or seal in chamber 2	Inspect piston, replace piston and/or seal

Primary Leak

If a leak is found for movement of piston 1 (primary leak), any leak described for piston movement 2 will cause a failure for piston 1 as well, as the liquid can move through the outlet valve to chamber 2. Such cases need to be identified as described before. Additionally, following causes are possible:

Probable cause	Suggested actions
1 Leak at piston 1 or seal in chamber 1	Inspect piston, replace piston and/or seal
2 Leak at inlet valve	Replace inlet valve or inlet valve cartridge (AIV only)

Internal Outlet Valve Leak

A leak of the outlet valve will be identified separately (internal outlet valve leak) by calculating the difference between leak rate 1 and leak rate 2. If the second leak rate is higher than the first one, this is due to a flow back through the outlet valve.

Probable cause	Suggested actions
1 Leak at outlet valve	Replace the part which has failed and re-run the test.

8 Test Functions and Calibration

Leak Rate Test



9 Diagnostic Signals

Analog Pressure Output	144
Diagnostic Signals in Chromatographic Data Systems	145
Instrument Signals	145

This chapter explains all diagnostic signals of the binary pump.



Analog Pressure Output

A BNC connector at the rear of the binary pump provides the reading of the pressure sensor as analog value with a resolution of 1.33 mV/bar. The maximum reading of 660 bar equals 800 mV. The signal is available in real time and can be fed into an appropriate recording device (e.g. integrator or strip chart recorder) for troubleshooting purposes.

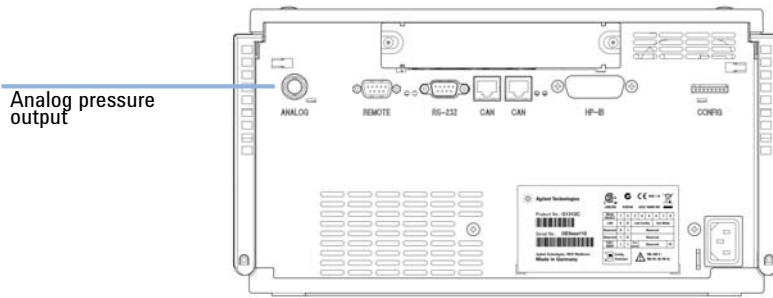

Figure 22 Location of analog output connector

Diagnostic Signals in Chromatographic Data Systems

Instrument Signals

In Chromatographic Data Systems (for example, Agilent OpenLAB CDS, or any 3rd party software that supports the ICF (Instrument Control Framework) standard), the following instrument parameters are accessible during data acquisition and can be stored in the data file:

- current pump pressure
- solvent composition (gradient)

9 Diagnostic Signals

Diagnostic Signals in Chromatographic Data Systems



10 Maintenance

Introduction to Maintenance and Repair	148
Warnings and Cautions	149
Cleaning the Module	151
Overview of Maintenance and Simple Repairs	152
Maintenance Procedures	153
Exchanging the Purge Valve Frit or the Purge Valve	154
Removing the Pump Head Assembly	157
Maintenance of a Pump Head without Seal Wash	159
Maintenance of a Pump Head with Seal Wash	163
Reinstalling the Pump Head Assembly	167
Seal Wear-in Procedure	169
Exchanging the Active Inlet Valve (AIV) or its Cartridge	170
Exchanging the Outlet Valve	173
Installation of the Solvent Selection Valve Upgrade Kit	175
Exchanging the Solvent Selection Valve	177
Exchanging the Optional Interface Board	180
Replacing Module Firmware	181

This chapter describes the maintenance of the module.



Introduction to Maintenance and Repair

The pump is designed for easy repair. The most frequent repairs such as piston seal replacement and purge valve frit exchange can be done from the front side without removing the pump from the system stack. These repairs are described in [“Overview of Maintenance and Simple Repairs”](#) on page 152 .

Warnings and Cautions

WARNING

Toxic, flammable and hazardous solvents, samples and reagents

The handling of solvents, samples and reagents can hold health and safety risks.

- When working with these substances observe appropriate safety procedures (for example by wearing goggles, safety gloves and protective clothing) as described in the material handling and safety data sheet supplied by the vendor, and follow good laboratory practice.
 - The volume of substances should be reduced to the minimum required for the analysis.
 - Do not operate the instrument in an explosive atmosphere.
-

WARNING

Electrical shock

Repair work at the module can lead to personal injuries, e.g. shock hazard, when the cover is opened.

- Do not remove the cover of the module.
 - Only certified persons are authorized to carry out repairs inside the module.
-

WARNING

Personal injury or damage to the product

Agilent is not responsible for any damages caused, in whole or in part, by improper use of the products, unauthorized alterations, adjustments or modifications to the products, failure to comply with procedures in Agilent product user guides, or use of the products in violation of applicable laws, rules or regulations.

- Use your Agilent products only in the manner described in the Agilent product user guides.
-

10 Maintenance

Warnings and Cautions

CAUTION

Safety standards for external equipment

- If you connect external equipment to the instrument, make sure that you only use accessory units tested and approved according to the safety standards appropriate for the type of external equipment.
-

CAUTION

Agilent 1260 Infinity pump heads have been discontinued for Agilent 1260 Infinity Binary Pumps

A number of 1260 Infinity Binary Pumps have been shipped with pump heads labeled as 1260 Infinity pump heads and passive inlet valves. While these parts are as good from a performance perspective, they are no longer used for 1260 Infinity Binary Pumps. Parts listed in this manual are not compatible to 1260 Infinity pump heads and may get damaged.

- Please contact your Agilent service representative.
-

Cleaning the Module

To keep the module case clean, use a soft cloth slightly dampened with water, or a solution of water and mild detergent.

WARNING

Liquid dripping into the electronic compartment of your module can cause shock hazard and damage the module

- Do not use an excessively damp cloth during cleaning.
 - Drain all solvent lines before opening any connections in the flow path.
-

Overview of Maintenance and Simple Repairs

Figure 23 on page 152 shows the main user accessible assemblies of the binary pump. The pump heads and its parts require normal maintenance (for example, seal exchange) and can be accessed from the front (simple repairs). Replacement of valve cartridges or filters don't require to remove the pump from the system stack.

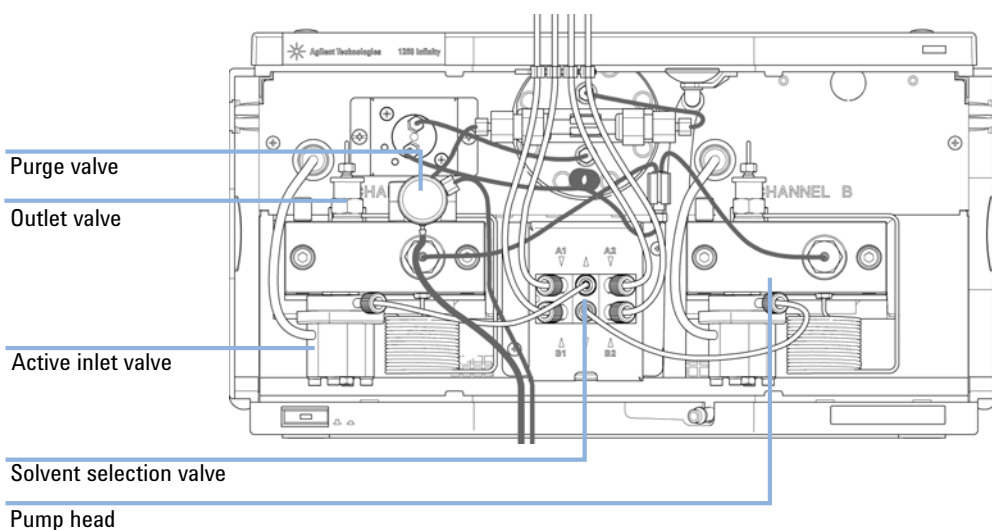

Figure 23 Overview of Maintenance and Simple Repairs

- | | |
|---|--|
| 1 | Purge valve, see “Exchanging the Purge Valve Frit or the Purge Valve” on page 154 |
| 2 | Outlet valve, see “Exchanging the Outlet Valve” on page 173 |
| 3 | Active inlet valve, see “Exchanging the Active Inlet Valve (AIV) or its Cartridge” on page 170 |
| 4 | Pump head, see “Removing the Pump Head Assembly” on page 157 |
| 5 | Solvent selection valve, see “Installation of the Solvent Selection Valve Upgrade Kit” on page 175 |

Maintenance Procedures

The procedures described in this section can be done with the binary pump in place in the system stack.

Table 12 Maintenance procedures

Procedure	Typical Frequency	Notes
"Exchanging the Purge Valve Frit or the Purge Valve" on page 154	Yearly, or if the frit shows indication of contamination or blockage If internally leaking	A pressure drop of > 10 bar in low delay volume configuration and > 20 bar in standard configuration across the frit (5 mL/min H ₂ O with purge valve open) indicates blockage Solvent dripping out of waste outlet when valve is closed
"Removing the Pump Head Assembly" on page 157	During yearly maintenance	Necessary to get access to pump seals and pistons
"Maintenance of a Pump Head without Seal Wash" on page 159	Yearly, or if pump performance indicates seal wear	Leaks at lower pump head side, unstable retention times, pressure ripple unstable — run Valve Test for verification Seal life time shorter than normally expected — check pistons while changing the seals
"Maintenance of a Pump Head with Seal Wash" on page 163	Yearly, or if pump performance indicates seal wear	Only necessary when Seal Wash Option is installed. Leaks at lower pump head side, loss of wash solvent
"Exchanging the Active Inlet Valve (AIV) or its Cartridge" on page 170	If leaking externally If solenoid is defective	Error messages "Inlet Valve Fuse" or "Inlet Valve Missing"
"Exchanging the Outlet Valve" on page 173	If internally leaking	Pressure ripple unstable, run Valve Test for verification
"Exchanging the Solvent Selection Valve" on page 177	If internally leaking If solenoid is defective	Cross port flow Error message "Valve Failed"

10 Maintenance

Exchanging the Purge Valve Frit or the Purge Valve

Exchanging the Purge Valve Frit or the Purge Valve

- When**
- Frit – when piston seals are exchanged or when contaminated or blocked (pressure drop of > 10 bar in low delay volume configuration and > 20 bar in standard configuration across the frit at a flow rate of 5 mL/min of water with purge valve opened)
 - Purge valve – if internally leaking

Tools required	p/n	Description
	8710-0510	Wrench open 1/4 — 5/16 inch
	8710-1924	Wrench open 14 mm
		Pair of tweezers
OR		Toothpick

Parts required	#	p/n	Description
	1	01018-22707	PTFE frits (pack of 5)
	1	G1312-60061	Purge valve 1260
	1	5067-4728	Seal cap (OPTIONAL)

- Preparations**
- Switch off pump at the main power switch
 - Remove the front cover
 - Use an optional solvent shutoff valve or lift up solvent filters in solvent reservoirs for avoiding leakages.

Exchanging the Purge Valve Frit or the Purge Valve

- 1 Using a 1/4 inch wrench disconnect the pump outlet capillary from the purge valve. Disconnect the waste tube. Beware of leaking solvents due to hydrostatic pressure.

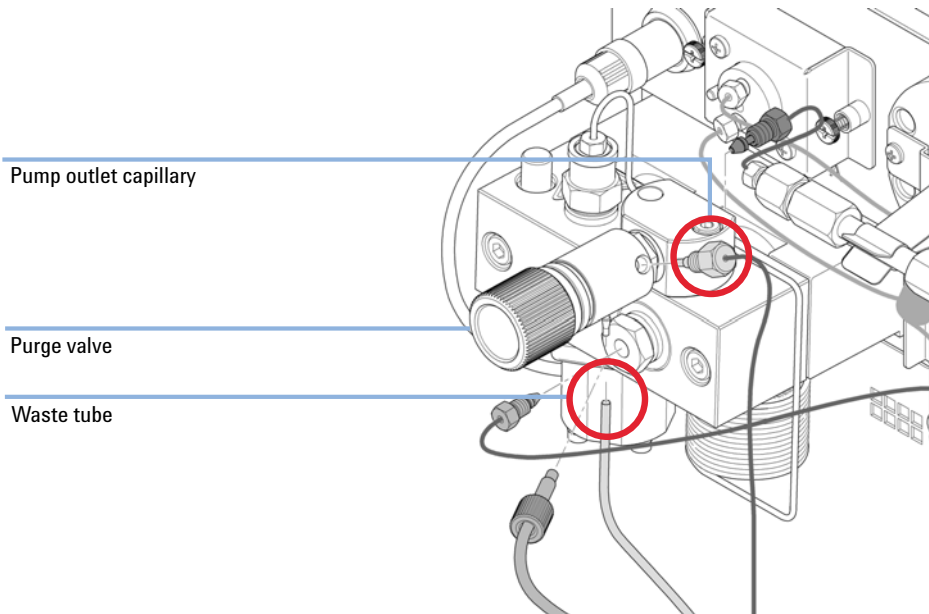

- 2 Using the 14 mm wrench, unscrew the purge valve and remove it from the purge valve holder.
- 3 Remove the seal cap from the purge valve.
- 4 Using a pair of tweezers or a toothpick remove the frit.

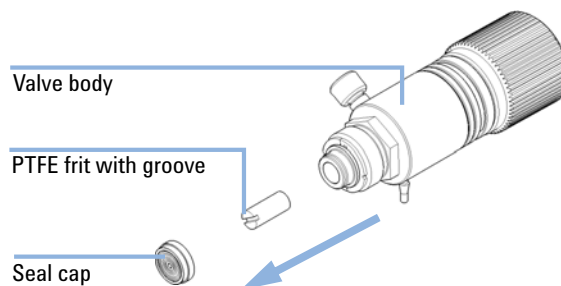

10 Maintenance

Exchanging the Purge Valve Frit or the Purge Valve

- 5 Place a new frit into the purge valve with the orientation of the frit as shown below (slit in frit points to the front). Reinstall the seal cap including the gold seal.

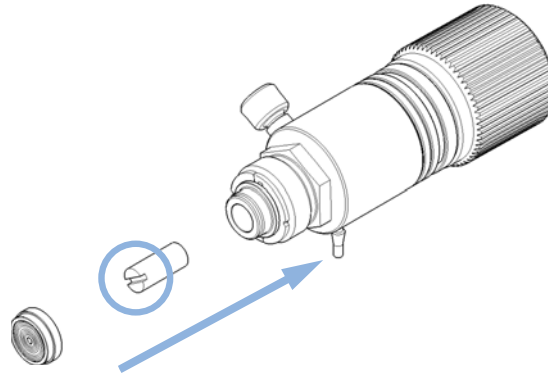

NOTE

Before reinstallation always check the gold seal in the seal cap. A deformed seal cap should be exchanged.

- 6 Insert the purge valve into the purge valve holder and orient the waste outlet nozzle downward.
- 7 Tighten the purge valve and reconnect outlet capillary and waste tubing.

Removing the Pump Head Assembly

- When**
- Exchanging pump seals
 - Exchanging pistons
 - Exchanging seals of the seal wash option

Tools required	p/n	Description
	8710-0510	Wrench open 1/4 — 5/16 inch
	8710-2411	Hex key 3 mm12 cm long
	8710-2392	Hex key 4 mm15 cm long T-handle
	5023-0240	Hex driver, ¼", slitted

Preparations Switch off the pump at the main power switch

CAUTION

Damage of the pump drive

Starting the pump when the pump head is removed may damage the pump drive.

→ Never start the pump when the pump head is removed.

NOTE

Both pump head assemblies use the same internal components. In addition, pump head A is fitted with the purge valve. The following procedure describes the removal and disassembly of pump head A (left). For pump head B (right) proceed in the same way and skip steps that deal with the purge valve.

- 1 Remove the front cover.
- 2 Disconnect the capillaries at the back of the purge valve holder, the pump head adapter and the tube at the active inlet valve. Beware of leaking solvents.

10 Maintenance

Removing the Pump Head Assembly

- Using a 4-mm hexagonal key stepwise loosen and remove the two pump head screws.

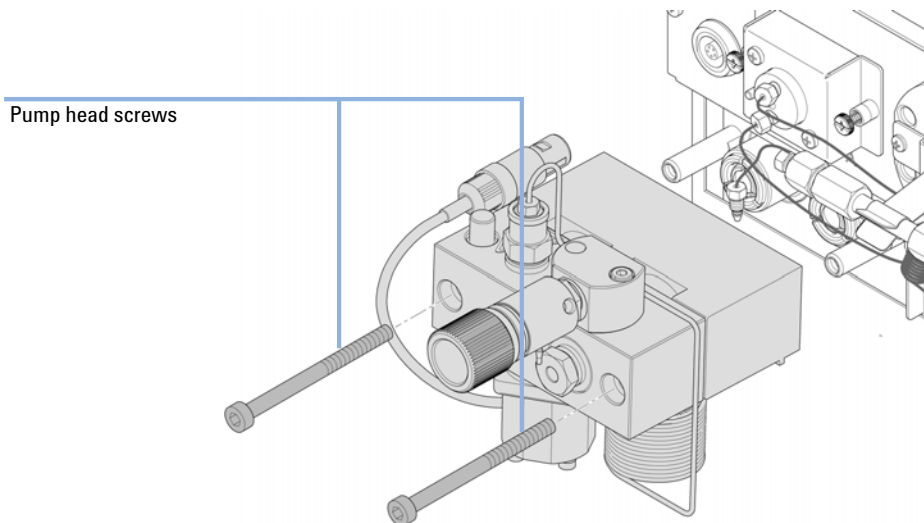

Maintenance of a Pump Head without Seal Wash

When In case of maintenance or pump head internal leaks

Tools required	p/n	Description
	8710-0510	Wrench open 1/4 — 5/16 inch
	8710-2411	Hex key 3 mm12 cm long
	8710-2392	Hex key 4 mm15 cm long T-handle
	01018-23702	Insert tool

Parts required	#	p/n	Description
	1	5063-6589	Piston seal PTFE, carbon filled, black (pack of 2), default
OR	1	0905-1420	PE seals (pack of 2)
	1	5063-6586	Sapphire piston

- Preparations**
- Switch off the pump at the main power switch
 - Remove the front cover to have access to the pump heads
 - [“Removing the Pump Head Assembly”](#) on page 157

NOTE

Both pump head assemblies use the same internal components. In addition, pump head A is fitted with the purge valve. The following procedure describes the removal and disassembly of pump head A (left). For pump head B (right) proceed in the same way and skip steps that deal with the purge valve.

10 Maintenance

Maintenance of a Pump Head without Seal Wash

- 1 Place the pump head on a flat surface. Loosen the lock screw (two turns) and while holding the lower half of the assembly (piston housing) carefully lift up the pump housing and remove it from the piston housing.

Lock screw

Pump housing

Piston housing

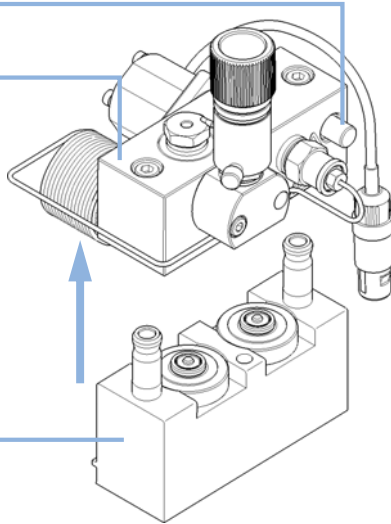

- 2 Remove the support rings from the piston housing and lift the housing away from the pistons.

Support ring

Piston housing

Piston

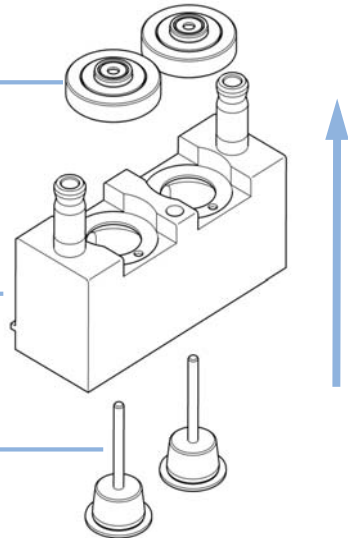

3 Check the piston surface and remove any deposits or layers. Most suitable is polishing of the piston rod with toothpaste. Replace the piston if scratched or if dents are visible.

Piston surface

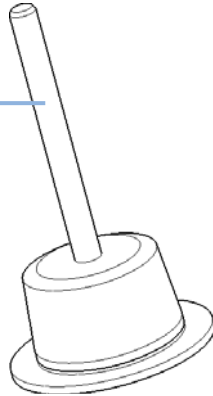

NOTE

The best way to inspect a piston is to hold it up and watch e.g. a light bulb through the piston rod. The transparent sapphire acts as a very strong magnifier and even smallest surface abnormalities become visible.

4 Using the steel side of the insert tool carefully remove the seal from the pump housing. Remove wear retainers, if still present.

Insert tool

Piston seal

Pump housing

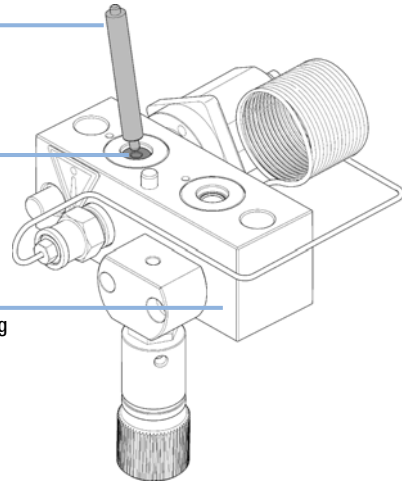

5 Using the plastic side of the insert tool insert the new seals into the pump head and press them firmly in position.

Insert tool

Piston seals

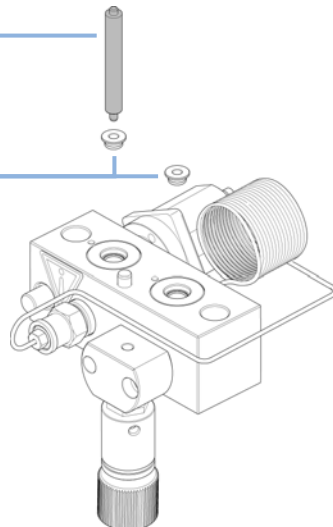

6 Place a seal wash gasket in the recess of the support ring. Put the seal holder on top of the gasket.

Seal holder

Gasket

Support ring

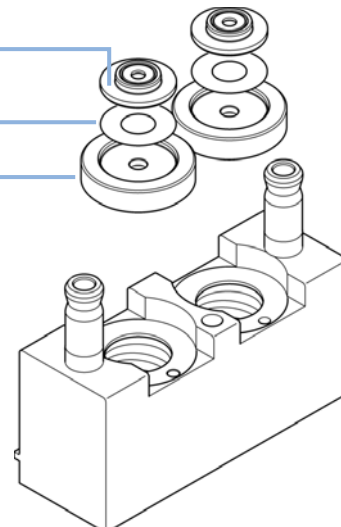

10 Maintenance

Maintenance of a Pump Head without Seal Wash

- 7** Reassemble the pump head assembly. Note the correct position of the pin on the support ring.

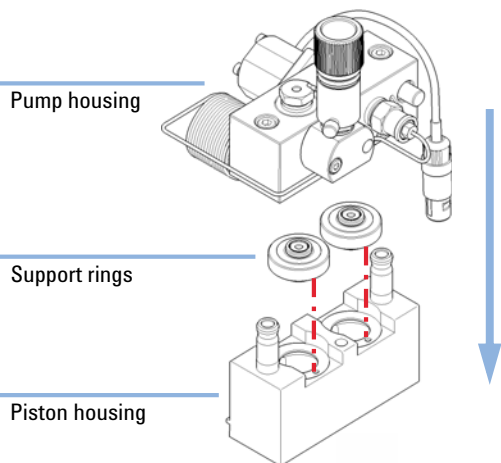

NOTE

Reset the seal wear counter and liquimeter in the Agilent Lab Advisor.

- 8** Insert the pistons and carefully press them into the seals.

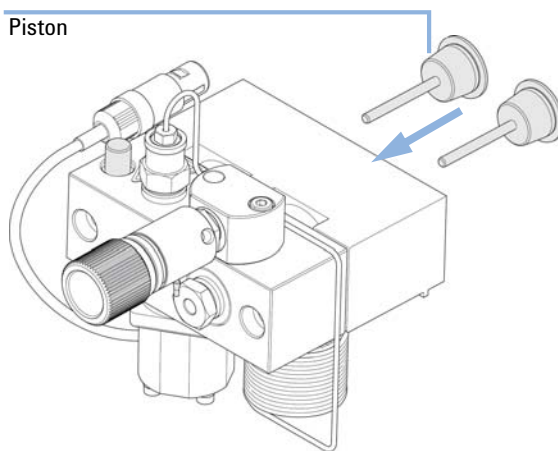

- 9** Tighten the lock screw.

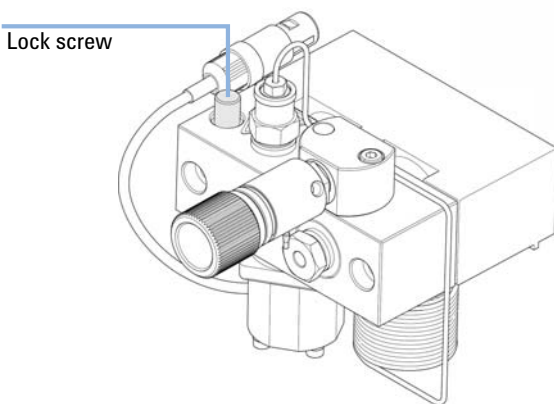

Next Steps:

- 10** Reinstall the pump head assembly, see [“Reinstalling the Pump Head Assembly”](#) on page 167.
- 11** If a standard seal has been installed, run the seal wear-in procedure, see [“Seal Wear-in Procedure”](#) on page 169.
- 12** For the normal phase seal, the purge valve frit should be replaced, see [“Exchanging the Purge Valve Frit or the Purge Valve”](#) on page 154.

Maintenance of a Pump Head with Seal Wash

When In case of maintenance or pump head internal leaks

Tools required	p/n	Description
	8710-2411	Hex key 3 mm12 cm long
	8710-2392	Hex key 4 mm15 cm long T-handle
	01018-23702	Insert tool
		Screwdriver, small flat head

Parts required	p/n	Description
	0905-1175	Wash seal (PTFE)
	5062-2484	Gasket, seal wash (pack of 6)
	5063-6586	Sapphire piston

- Preparations**
- Switch off the pump at the main power switch
 - Remove the front cover to have access to the pump heads
 - [“Removing the Pump Head Assembly”](#) on page 157

NOTE

Both pump head assemblies use the same internal components. In addition, pump head A is fitted with the purge valve. The following procedure describes the removal and disassembly of pump head A (left). For pump head B (right) proceed in the same way and skip steps that deal with the purge valve.

10 Maintenance

Maintenance of a Pump Head with Seal Wash

- 1** Place the pump head on a flat surface. Loosen the lock screw (two turns) and while holding the lower half of the assembly (piston housing) carefully lift up the pump housing and remove it from the piston housing.

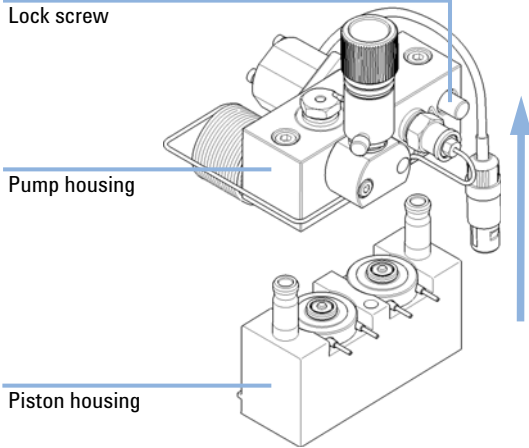

- 2** Remove the seal holder and the seal wash support rings from the piston housing. Remove the seal holder from the support ring assembly.

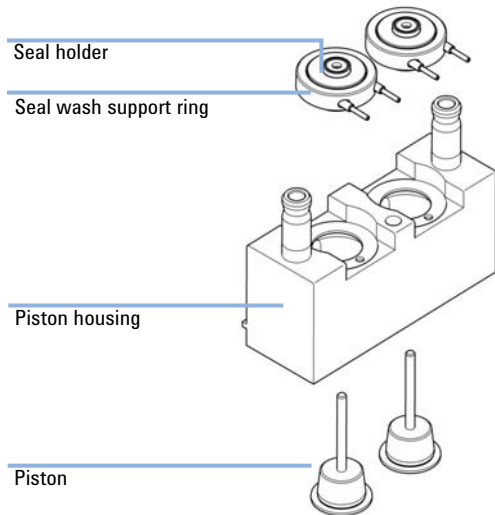

- 3** Check the piston surface and remove any deposits or layers. Most suitable is polishing of the piston rod with toothpaste. Replace the piston if scratched or if dents are visible.

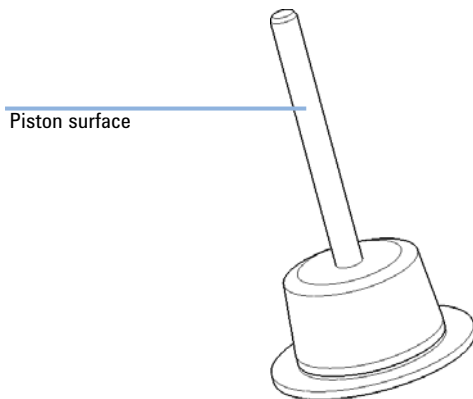

NOTE

The best way to inspect a piston is to hold it up and watch e.g. a light bulb through the piston rod. The transparent sapphire acts as a very strong magnifier and even smallest surface abnormalities become visible.

- 4** Using the steel side of the insert tool carefully remove the seal from the pump housing. Remove wear retainers, if still present.

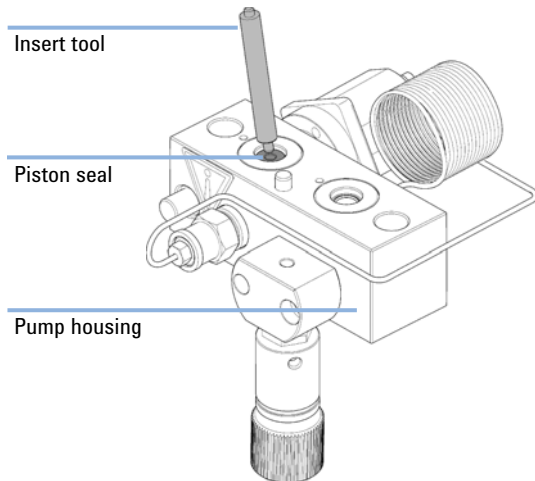

5 Using the plastic side of the insert tool insert the new seals into the pump head and press them firmly in position.

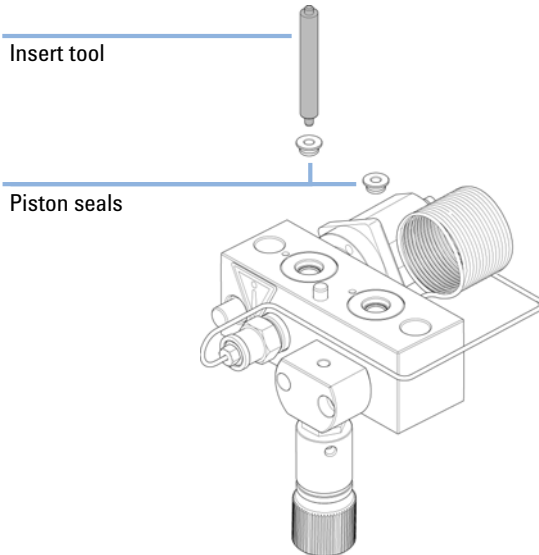

6 Using the steel side of the insert tool remove the seal wash gasket and the wash seal from the support ring. The removed seal will be damaged and cannot be re-used!

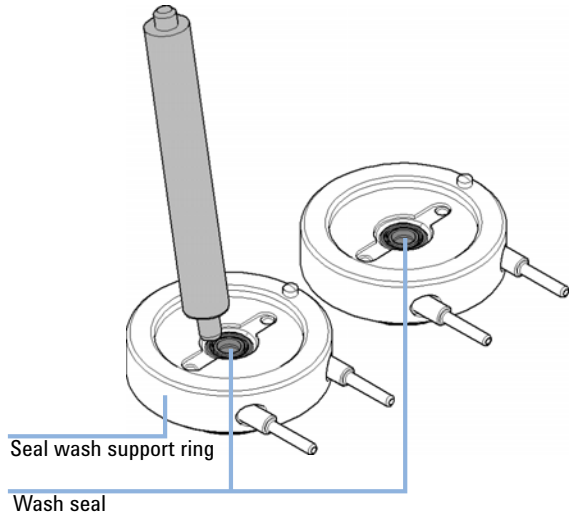

7 Using the plastic side of the insert tool press the new wash seal (spring pointing upwards) into the recess of the support ring.

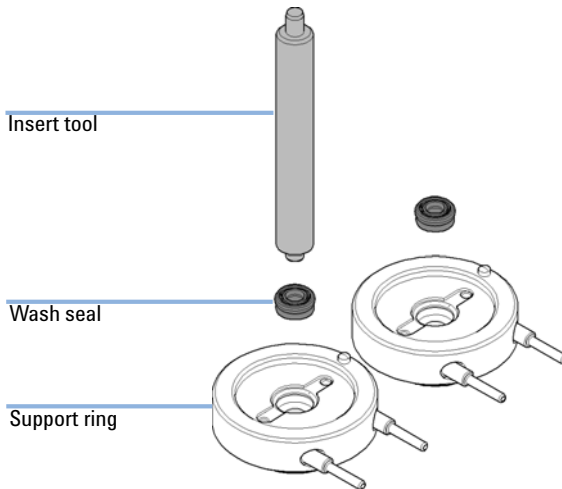

8 Place a seal wash gasket in the recess of the support ring. Put the seal holder on top of the gasket.

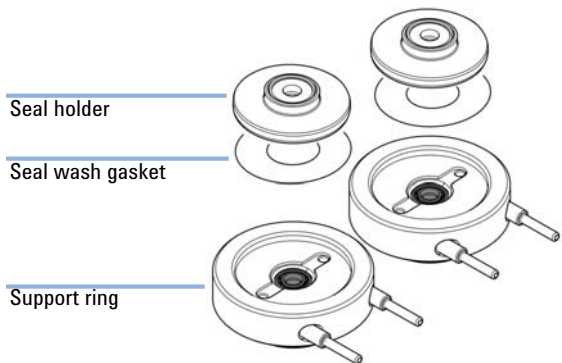

10 Maintenance

Maintenance of a Pump Head with Seal Wash

- 9** Place the support rings on the piston housing (pistons not installed) and snap the pump housing and piston housing together. Note the correct position of the pin on the support ring.

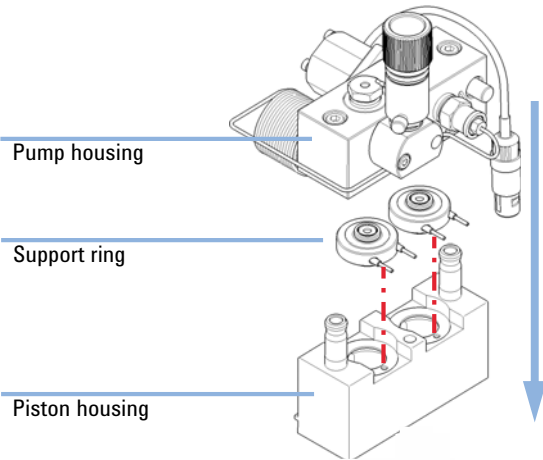

- 10** Insert the pistons and carefully press them into the seals.

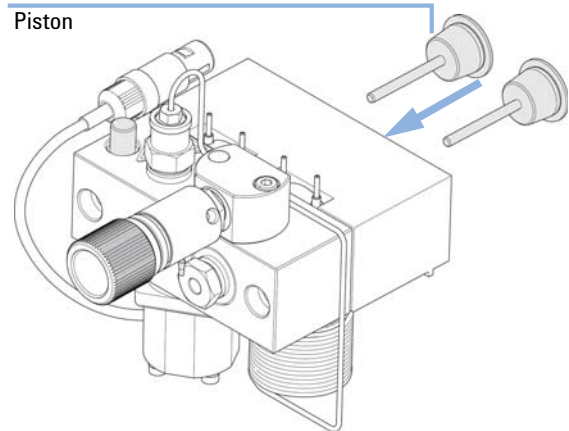

- 11** Tighten the lock screw.

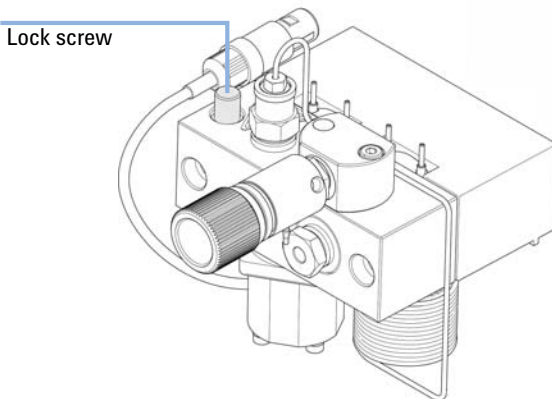

- 12** Reinstall the pump head assembly, see [“Reinstalling the Pump Head Assembly”](#) on page 167.

Reinstalling the Pump Head Assembly

When When reassembling the pump

Tools required	p/n	Description
	8710-2411	Hexagonal key, 3 mm
		Hexagonal key, 4 mm

Parts required	#	p/n	Description
	1	79846-65501	Pump head grease

- 1 Slide the pump head assembly onto the pump drive.

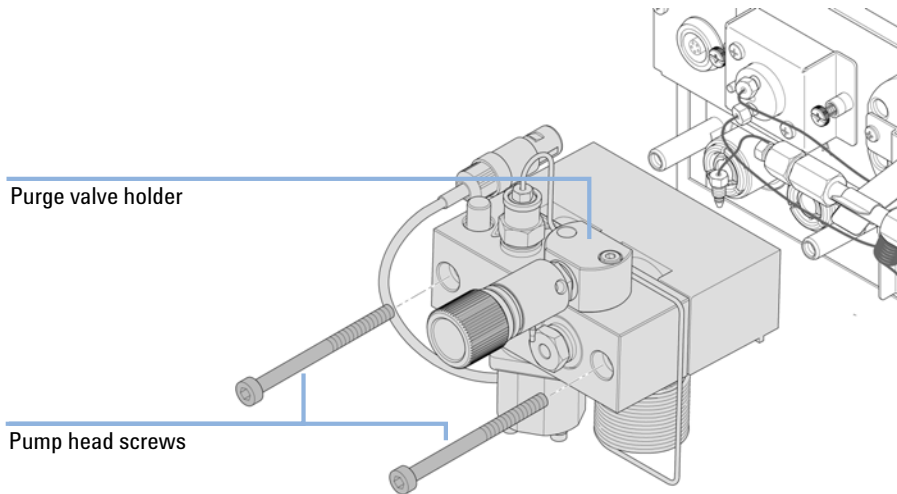

- 2 Using a 4 mm hexagonal key tighten the pump head screws stepwise with increasing torque.

10 Maintenance

Reinstalling the Pump Head Assembly

- 3 Reconnect the tubing and capillaries to the connector.

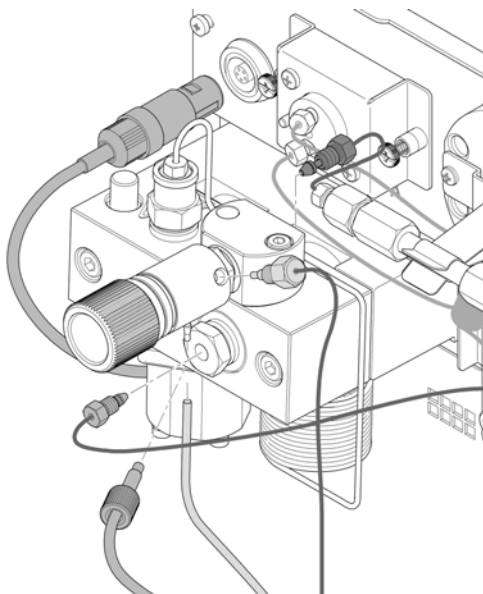

Seal Wear-in Procedure

CAUTION

Seal damage

This procedure is required for black PTFE seals (standard applications, p/n 5063-6589), but it will damage the yellow PE seals (normal phase applications, p/n 0905-1420).

→ Do not run the seal wear-in procedure if PE seals are installed in the pumphead.

- 1 Put a bottle with 100 ml of isopropanol in the solvent cabinet and place the solvent intake filter of the pump head you want to wear in into this bottle.
- 2 Screw the PEEK adapter 1/4-28 to 10-32 (0100-1847) onto the active inlet valve and connect the inlet tube from the bottle head directly to it.
- 3 Connect the Restriction capillary (5022-2159) to the purge valve. Connect its other end to a waste container.
- 4 Open the purge valve and purge the system for 5 min with isopropanol at a flow rate of 2 mL/min.
- 5 Close the purge valve, set the flow to a value that gives a pressure of 350 bar. Pump 15 min at this pressure to wear the seals in. The pressure can be monitored on the analog output connector of the pump, with the Instant Pilot, chromatographic data system or any other controlling device connected to your pump.
- 6 Turn OFF the pump, slowly open the purge valve to release the pressure from the system, disconnect the restriction capillary and reconnect the outlet capillary to the purge valve. Reconnect the intake tubing to the solvent selection valve and the connecting tube from the solvent selection valve (if installed) to the AIV.
- 7 Purge your system with the solvent used for your next application.

10 Maintenance

Exchanging the Active Inlet Valve (AIV) or its Cartridge

Exchanging the Active Inlet Valve (AIV) or its Cartridge

When If internally leaking (backflow)

Tools required **Description**
Wrench, 14 mm

Parts required

p/n	Description
G1312-60025	Active inlet valve body, without cartridge
G1312-60020	Cartridge for active inlet valve 600 bar

Preparations Switch off the pump at the main power switch

CAUTION

Ensure correct fit of the active inlet valve
Overtightening will destroy the active inlet valve cartridge.
→ Tighten the active inlet valve properly.

- 1 Remove the front cover.
- 2 Unplug the active inlet valve cable from the connector.
- 3 Disconnect the solvent inlet tube at the inlet valve (beware of leaking solvents).

NOTE

Binary pumps without solvent selection valve (SSV) have an adapter installed between the solvent line and the active inlet valve (AIV). Disconnect the solvent tubes at the adapter and remove the adapter from the AIV.

Exchanging the Active Inlet Valve (AIV) or its Cartridge

- Using a 14 mm wrench, loosen the active inlet valve and remove the valve from the pump head.

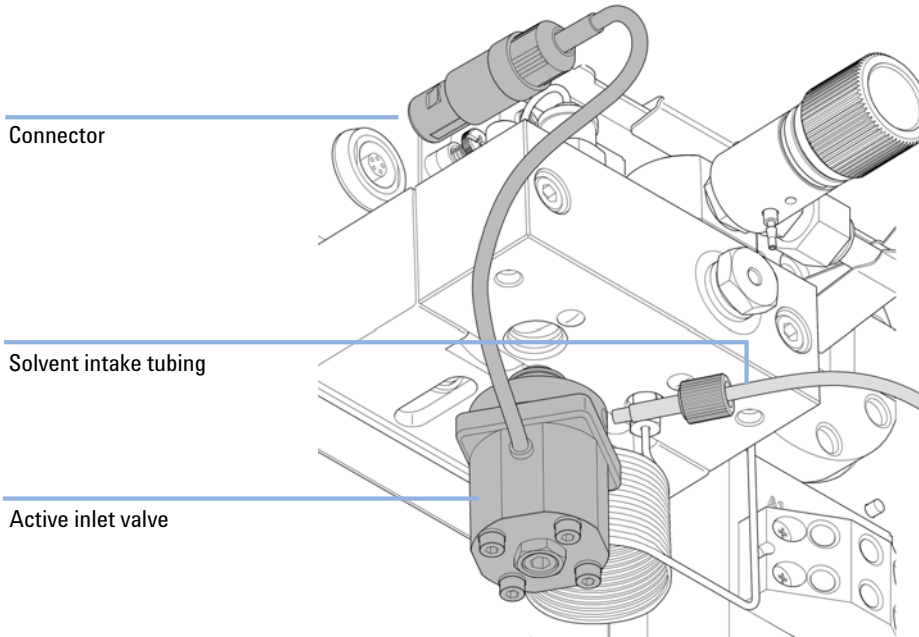

- Using a pair of tweezers, remove the valve cartridge from the defective active inlet valve.

10 Maintenance

Exchanging the Active Inlet Valve (AIV) or its Cartridge

- 6 Push the cartridge into the new active inlet valve.

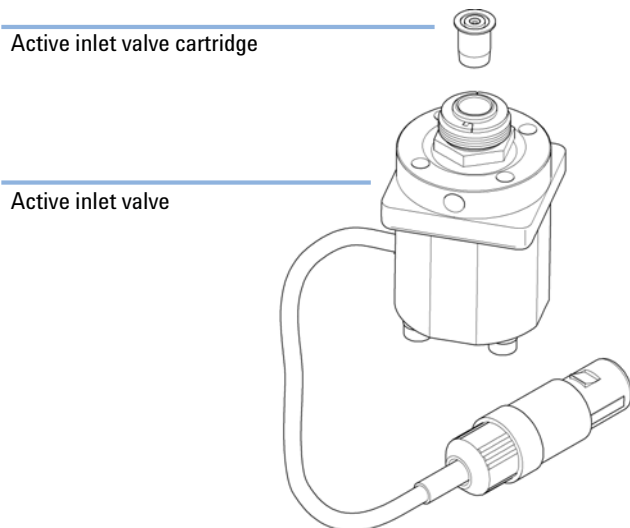

- 7 Screw the new valve into the pump head. With the 14 mm wrench turn the nut until it is hand tight.
- 8 Position the valve so that the solvent inlet tube connection points towards the front.
- 9 Using the 14 mm wrench tighten the nut by turning the valve in its final position (not more than a quarter turn). Do not overtighten the valve.
- 10 Reconnect the Active Inlet Valve cable to the connector in the Z-panel and the inlet tube to the valve.
- 11 Reinstall the front cover.

NOTE

After an exchange of the valve it may be required to pump several mL of the solvent used in the current application before the flow stabilizes at a pressure ripple as low as it used to be when the system was still working properly.

Exchanging the Outlet Valve

When if leaking internally

Tools required

Description
Wrench, 1/4 - 1/5 inch
Wrench 1/4 inch
Wrench, 14 mm

Parts required

p/n	Description
G1312-60067	Outlet valve 1220/1260

Preparations Switch off the pump at the main power switch

- 1 Using a 1/4 inch wrench disconnect the absorber capillary from the outlet valve.
- 2 Unscrew the valve with the 14 mm wrench and remove it from the pump body.
- 3 Do not disassemble the outlet valve, as this can damage the valve.

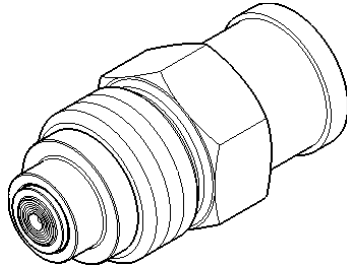

- 4 Reinstall the outlet valve and tighten it using a torque wrench (12 Nm).

10 Maintenance

Exchanging the Outlet Valve

- 5 Reconnect the capillary.

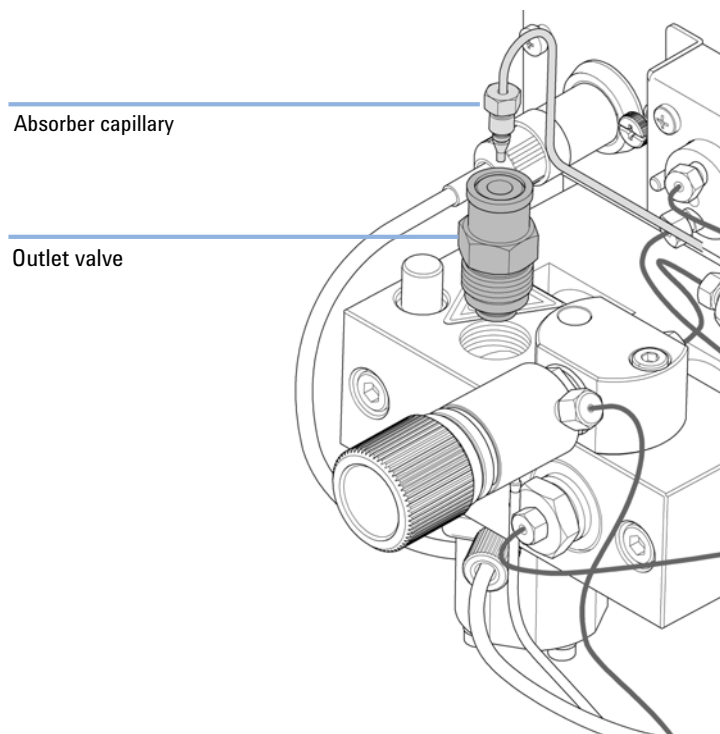

Installation of the Solvent Selection Valve Upgrade Kit

A solvent selection valve allows you to choose between four different solvents that can be used with a binary pump. The valve switches between two solvents A1 and A2 for channel A of the left pump head and two solvents B1 and B2 for channel B of the right pump head.

When Applicable modules: This kit is compatible to the 1260 Infinity Binary Pumps G1312B and G1312C and to the 1260 Infinity Binary Pump Clinical ed. K1312B.

Tools required **Description**
Screwdriver Pozidriv #1

Parts required	p/n	Description
	G1381-60000	Solvent Selection Valve Upgrade Kit

Preparations If required, remove solvent tubes from the inlet valves.

NOTE

The figures below show a Binary Pump G1312B. The kit can be used similarly for the Binary Pump G1312C and for the Binary Pump Clinical ed. K1312B.

10 Maintenance

Installation of the Solvent Selection Valve Upgrade Kit

- 1** Remove the front cover sheet by removing both screws.

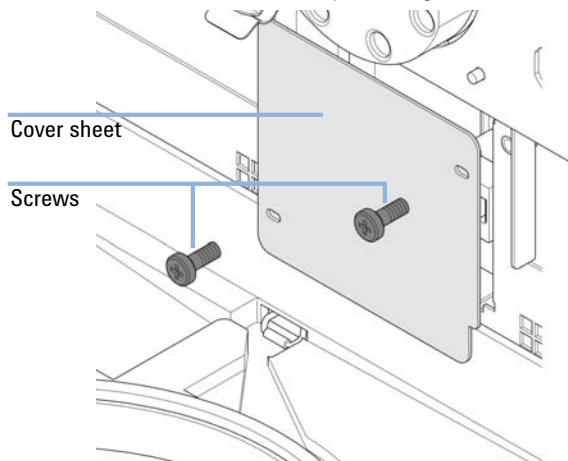

- 2** Plug in the connector of the solvent selection valve

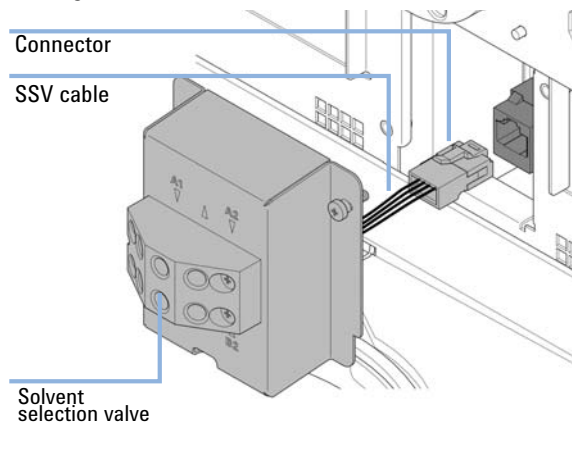

- 3** Install the solvent selection assembly by fixing both indicated screws.

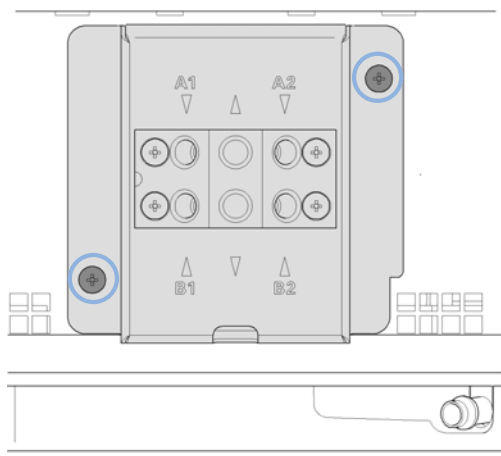

- 4** Connect the outlet for solvent A (upper row) to the inlet valve of the left pump head. Connect the outlet for solvent B (lower row) to the inlet valve of the right pump head. Put the solvent bottles into the solvent cabinet. Connect the bottle heads of solvents A1 and A2 to the inlets in the upper row, see labels on valve assembly. Connect the bottle heads of solvents B1 and B2 to the inlets in the lower row, see labels on valve assembly.

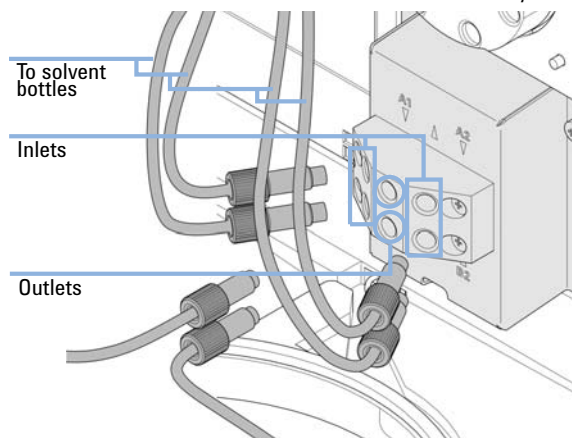

For controlling the solvent selection valve, please refer to the online help or user manual of your control software.

Exchanging the Solvent Selection Valve

When If leaking internally (crossflow between the ports), or if one of the channels is blocked

Tools required	p/n	Description
	8710-0899	Screwdriver, Pozidriv #1

Parts required	p/n	Description
	G1381-60000	Solvent Selection Valve Upgrade Kit

Preparations Switch off the pump at the main power switch

1 Lift solvent bottles out of the solvent cabinet and place them on the table. Disconnect the solvent tubes from the solvent selection valve and empty the tubes into the bottles. Place the bottles back into the solvent cabinet.

2 Disconnect all tubings from the solvent selection valve.

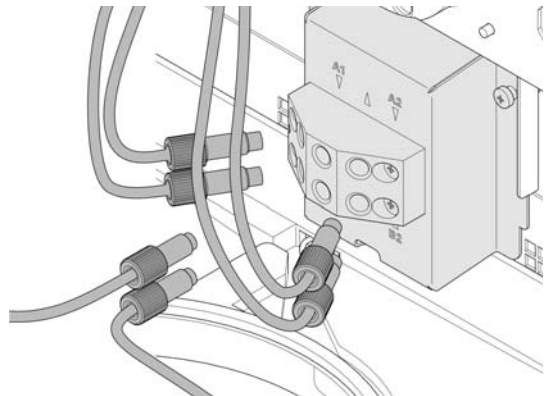

10 Maintenance

Exchanging the Solvent Selection Valve

- 3** Using a Pozidriv screwdriver #1 loosen the holding screws of the valve holder.

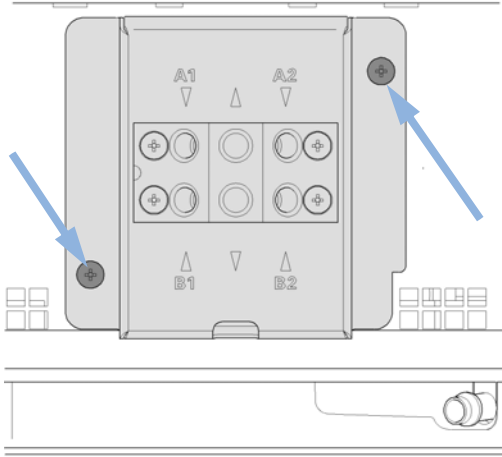

- 4** Carefully pull the valve holder out and disconnect the valve cable at the connector.

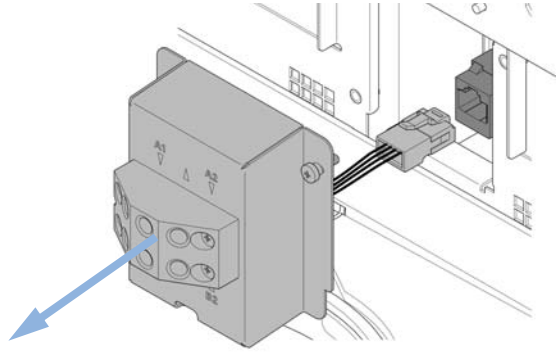

- 5** Exchange the defective solvent selection valve.

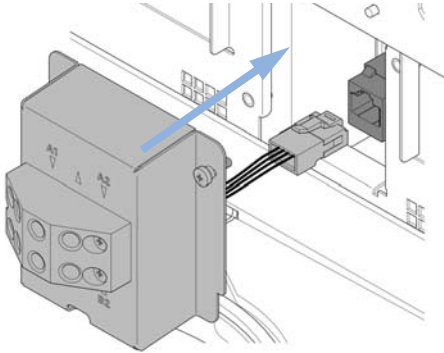

- 6** Tighten the screws of the valve holder.

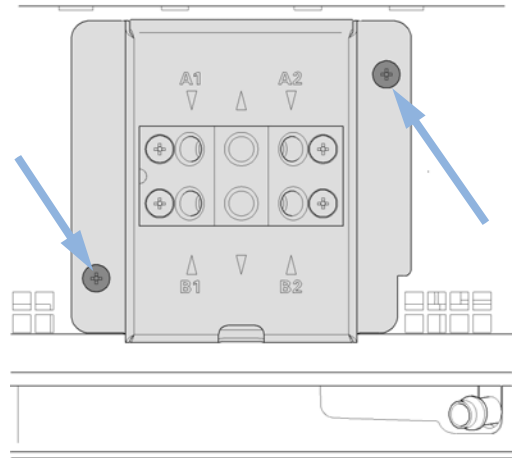

7 Reconnect all tubings to the solvent selection valve.

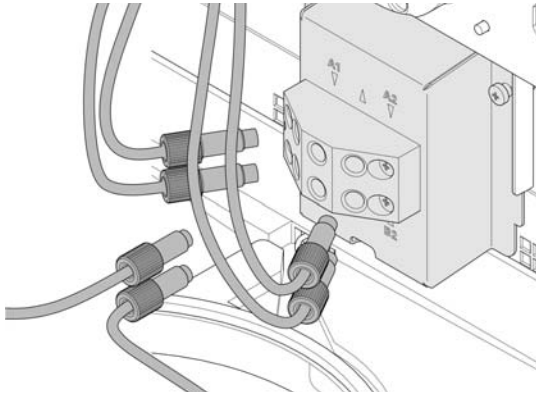
**NOTE**

After an exchange of the valve it may be required to pump several mL of solvent before the flow stabilizes at a pressure ripple as low as it used to be when the system was still working properly.

10 Maintenance

Exchanging the Optional Interface Board

Exchanging the Optional Interface Board

When Board defective

Parts required	#	Description
	1	BCD (Interface) board

Preparations

- Switch OFF the module at the main power switch.
- Unplug the module from main power.

CAUTION

Electronic boards and components are sensitive to electrostatic discharge (ESD). ESD can damage electronic boards and components.

→ In order to prevent damage always use an ESD protection when handling electronic boards and components.

- 1 Disconnect cables from the interface board connectors.
- 2 Loosen the screws. Slide out the interface board from the module.

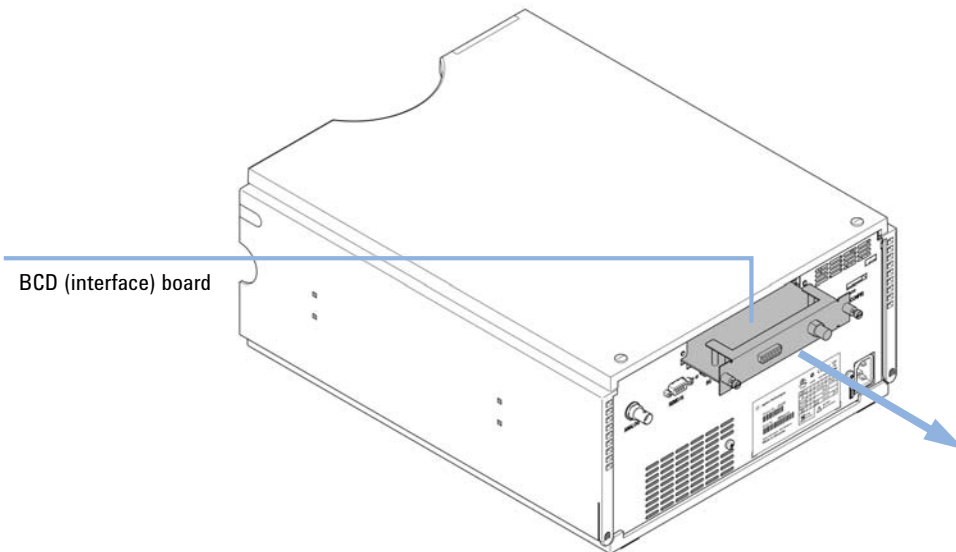

Figure 24 Exchanging the Interface Board

- 3 Install the new interface board. Secure the screws.
- 4 Reconnect the cables to the board connector

Replacing Module Firmware

When	<p>The installation of newer firmware might be necessary</p> <ul style="list-style-type: none"> • if a newer version solves problems of older versions or • to keep all systems on the same (validated) revision. <p>The installation of older firmware might be necessary</p> <ul style="list-style-type: none"> • to keep all systems on the same (validated) revision or • if a new module with newer firmware is added to a system or • if third party control software requires a special version.
-------------	--

Tools required	Description
	LAN/RS-232 Firmware Update Tool
OR	Agilent Lab Advisor software
OR	Instant Pilot G4208A (only if supported by module)

Parts required	#	Description
	1	Firmware, tools and documentation from Agilent web site

Preparations Read update documentation provided with the Firmware Update Tool.

To upgrade/downgrade the module's firmware carry out the following steps:

- 1 Download the required module firmware, the latest LAN/RS-232 FW Update Tool and the documentation from the Agilent web.
 - http://www.chem.agilent.com/_layouts/agilent/downloadFirmware.aspx?whid=69761
- 2 For loading the firmware into the module follow the instructions in the documentation.

Module Specific Information

Table 13 Module Specific Information (G1312B)

G1312B Binary pump	
NOTE	
<p>The module G1312B exists both as part of the 1200 Series and 1260 Infinity product lines. These modules use different solvent selection valves and main boards.</p> <p>Latest firmware revisions in each set automatically recognize the main board type and can be used without special handling.</p>	
<ul style="list-style-type: none">• A.06.06 [020]• A.06.10 [020]• A.06.34 [001]• A.06.53 [002]	<p>These revisions recognize the board type and shall be used. A.06.06 is the minimum version, which is compatible to 1260 Infinity Binary Pumps G1312B.</p> <p>Older G1312B firmware is only compatible to 1200 Series Binary Pumps SL G1312B.</p> <p>All listed firmware revisions allow emulation of G1312A pumps. Please consult the Firmware Update Guide for 1200 Infinity Systems for details.</p>



11 Parts and Materials for Maintenance

Hydraulic Path with Solvent Selection Valve	184
Hydraulic Path without Solvent Selection Valve	186
Pump Head Assembly Without Seal Wash	188
Pump Head Assembly with Seal Wash Option	190
Outlet Valve	192
Purge Valve Assembly	193
Active Inlet Valve Assembly	194
HPLC Starter Kit G4201-68707	195
HPLC Starter Kit G4202-68707	195
HPLC System Tool Kit	196
Bottle Head Assembly	197
Solvent Cabinet	198

This chapter lists all parts and tools that are required for maintenance.



Hydraulic Path with Solvent Selection Valve

Item	p/n	Description
1	G1322-67300	Kit of 4 solvent tubes including labels for connection degasser to SSV
2	G1312-60068	1260 Infinity Solvent selection valve (includes holder)
	5041-8365	Blank plug for unused SSV channels
3	G1312-60003	Connecting tube 1260 Infinity Solvent selection valve to active inlet valve
4	G1312-60025	Active inlet valve body, without cartridge
5	G1312-60045	Pump head assembly with seal wash
6	G1312-60067	Outlet valve 1220/1260
7	G1312-87300	Absorber capillary
8	G1312-67302	Capillary, channel A and B pump head outlet to mixing chamber (included)
9	G1312-87301	Restriction capillary (mixing capillary to pressure sensor)
11	G1312-87305	Capillary SSL, 0.17 x 150 mm (pressure sensor to damper)
13	G1312-87330	Mixer
14	G1312-87306	Capillary SSL, 0.17 x 105 mm (connections to solvent mixer)
	G1312-04100	Bracket for solvent mixer
15	G1312-60061	Purge valve 1260
	5042-8507	Peristaltic pump cartridge, silicone tubing
	5065-9978	Tubing, 1 mm i.d., 3 mm o.d., silicone, 5 m, for seal wash option
16	G1312-87303	Capillary ST 0.17 mm x 400 mm S/S
	G1312-87304	Capillary ST 0.17 mm x 700 mm S/S
17	5062-2461	Waste tube, 5 m (reorder pack)

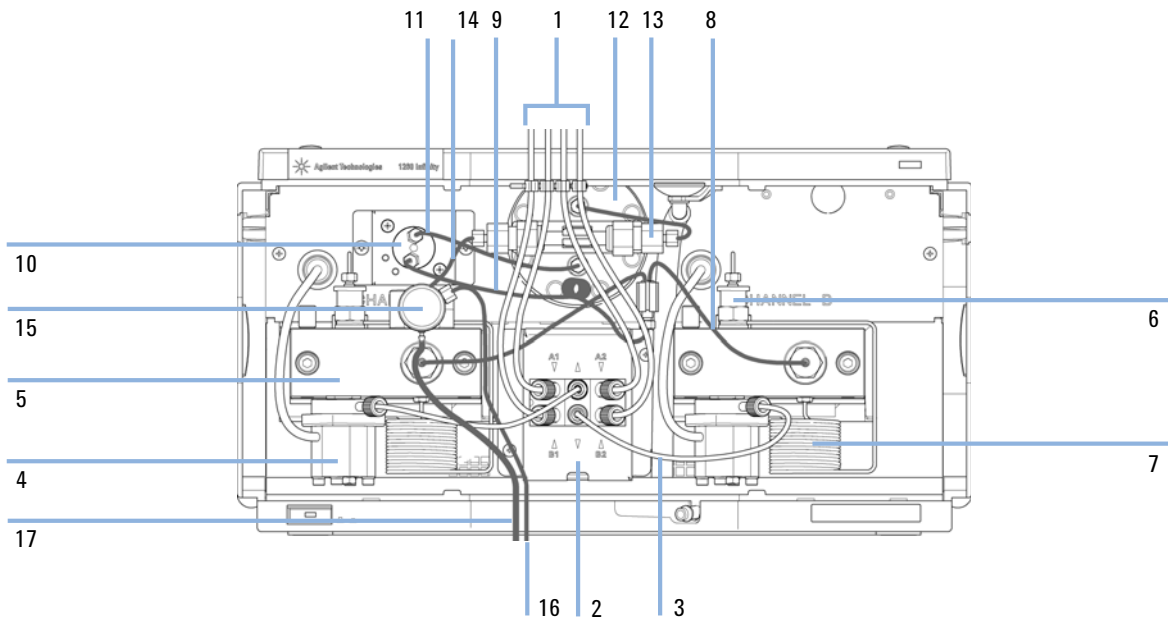

Figure 25 Hydraulic Path with Solvent Selection Valve

Hydraulic Path without Solvent Selection Valve

Item	p/n	Description
1	G1322-67300	Kit of 4 solvent tubes including labels for connection degasser to SSV
2	0100-1847	PEEK adapter 1/4-28 to 10-32 (Adapter AIV to solvent inlet tubes)
3	G1312-60025	Active inlet valve body, without cartridge
4	G1312-60056	Pump Head 1200 SL without Seal Wash
5	G1312-60067	Outlet valve 1220/1260
6	G1312-87300	Absorber capillary
7	G1312-67302	Capillary, channel A and B pump head outlet to mixing chamber (included)
8	G1312-87301	Restriction capillary (mixing capillary to pressure sensor)
10	G1312-87305	Capillary SSL, 0.17 x 150 mm (pressure sensor to damper)
12	G1312-87330	Mixer
13	G1312-87306	Capillary SSL, 0.17 x 105 mm (connections to solvent mixer)
	G1312-04100	Bracket for solvent mixer
14	G1312-60061	Purge valve 1260
15	G1312-87303	Capillary ST 0.17 mm x 400 mm S/S
	G1312-87304	Capillary ST 0.17 mm x 700 mm S/S
16	5062-2461	Waste tube, 5 m (reorder pack)
17	5042-8507	Peristaltic pump cartridge, silicone tubing
18	5065-9978	Tubing, 1 mm i.d., 3 mm o.d., silicone, 5 m, for seal wash option

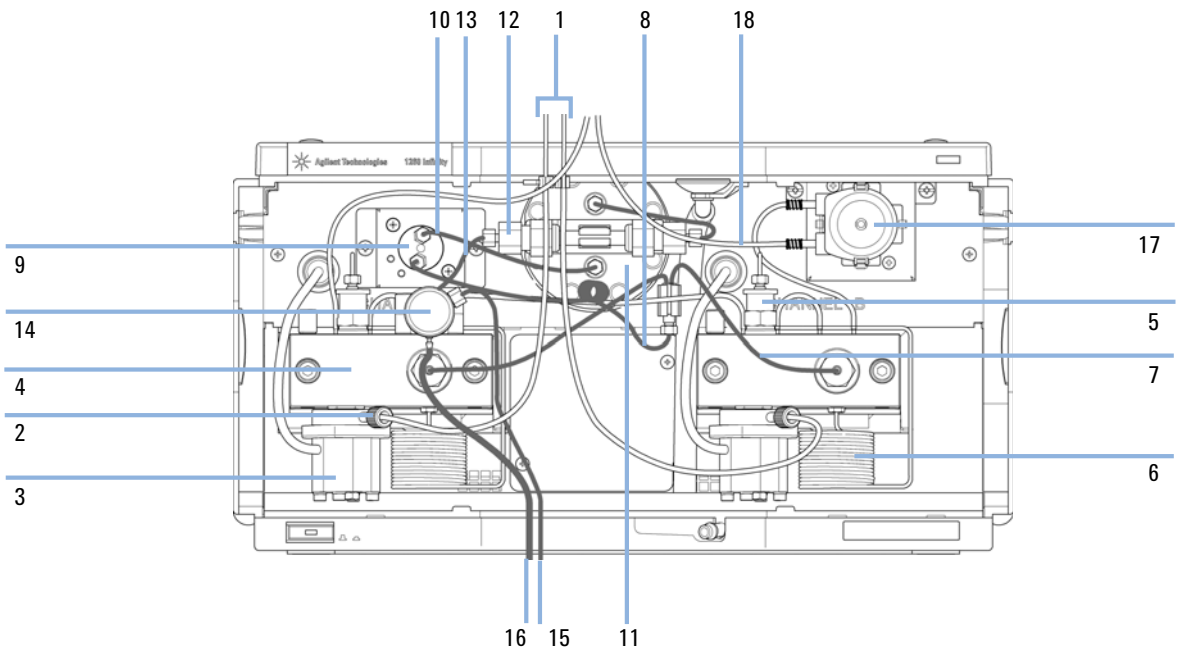

Figure 26 Hydraulic Path without Solvent Selection Valve, with Active Seal Wash

Pump Head Assembly Without Seal Wash

Item	p/n	Description
	G1312-60056	Pump Head 1200 SL without Seal Wash
1	5063-6586	Sapphire piston
2	G1311-60002	Piston housing
3	5067-1560	Support Ring SL, no seal wash
4	5062-2484	Gasket, seal wash (pack of 6)
5	5042-8952	Seal holder
6	G1312-87300	Absorber capillary
7	5063-6589	Piston seal PTFE, carbon filled, black (pack of 2), default
8	G1311-25200	Pump chamber housing
9	0515-0175	Mounting screw for manual purge valve holder, M4, 20 mm long
10	G1312-23200	Holder for manual purge valve
11	G1312-60061	Purge valve 1260
12	G1312-60067	Outlet valve 1220/1260
13	5042-1303	Lock screw
14a	G1312-60025	Active inlet valve body, without cartridge
14b	G1312-60020	Cartridge for active inlet valve 600 bar
15	G1312-23201	Adapter
16	0515-2118	Pump head screw (M5, 60 mm)

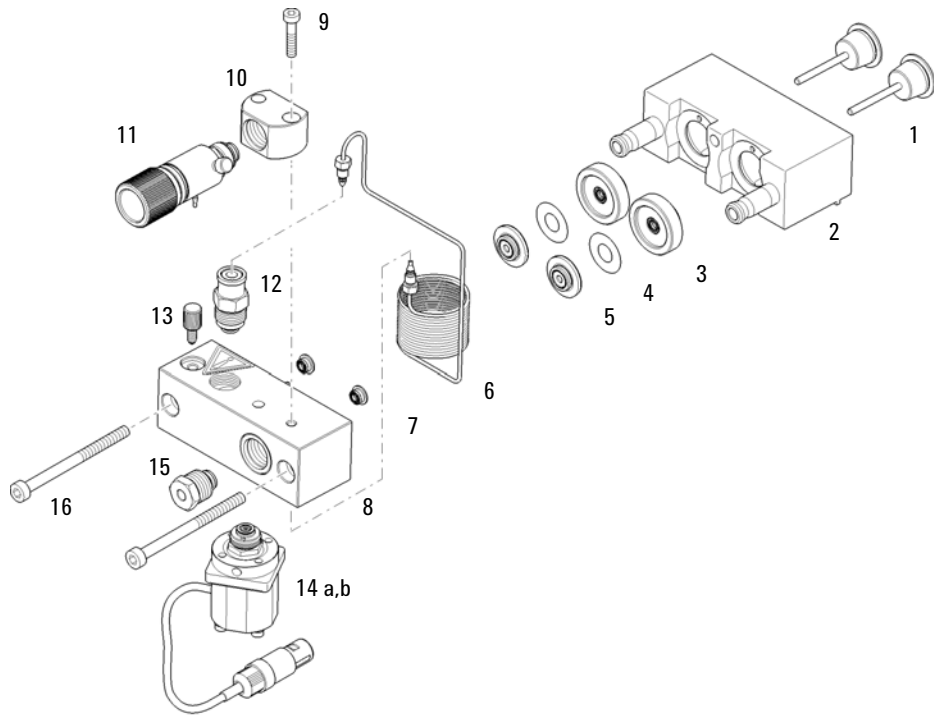

Figure 27 Pump Head Assembly Without Seal Wash

Pump Head Assembly with Seal Wash Option

Item	p/n	Description
	G1312-60045	Pump head assembly with seal wash
1	5042-8507	Peristaltic pump cartridge, silicone tubing
	5065-9978	Tubing, 1 mm i.d., 3 mm o.d., silicone, 5 m, for seal wash option
2	5063-6586	Sapphire piston
3	G1311-60002	Piston housing
4	01018-60027	Support ring seal wash
5	0905-1175	Wash seal (PTFE)
6	5062-2484	Gasket, seal wash (pack of 6)
7	5042-8952	Seal holder
8	G1312-87300	Absorber capillary
9	5063-6589	Piston seal PTFE, carbon filled, black (pack of 2), default
10	0515-0175	Mounting screw for manual purge valve holder, M4, 20 mm long
11	G1312-23200	Holder for manual purge valve
12	G1312-60061	Purge valve 1260
13	G1312-60067	Outlet valve 1220/1260
14	5042-1303	Lock screw
15	G1311-25200	Pump chamber housing
16a	G1312-60025	Active inlet valve body, without cartridge
16b	G1312-60020	Cartridge for active inlet valve 600 bar
17	G1312-23201	Adapter
18	0515-2118	Pump head screw (M5, 60 mm)

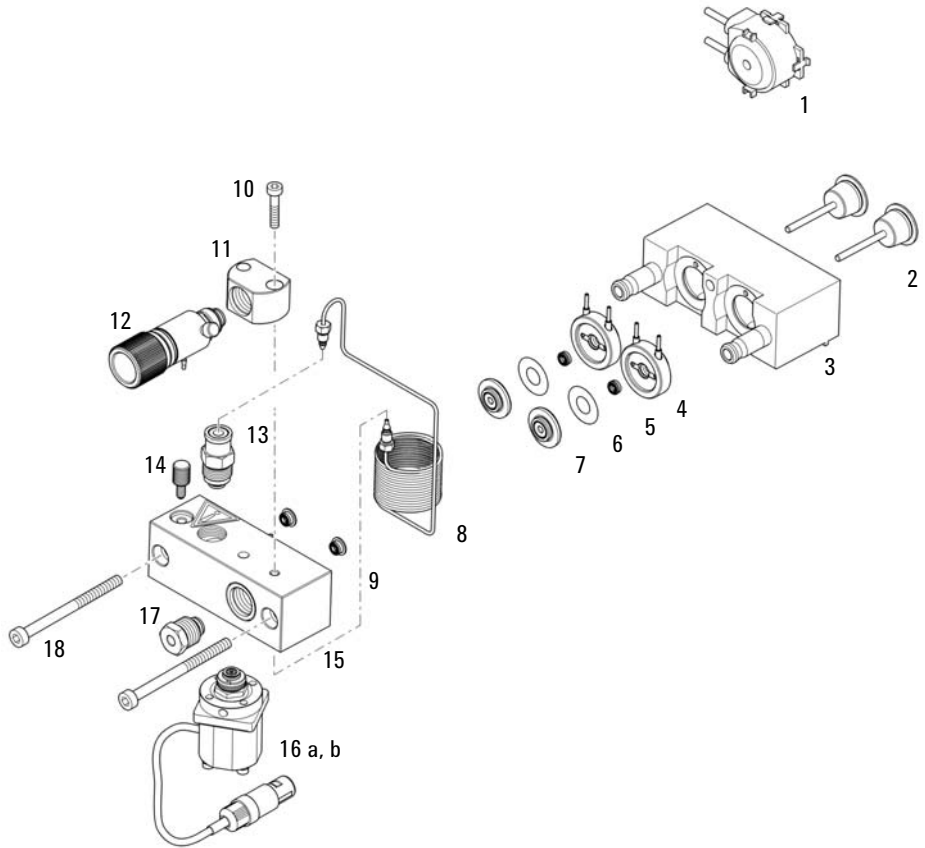

Figure 28 Pump head assembly with seal wash option

11 Parts and Materials for Maintenance

Outlet Valve

Outlet Valve

p/n	Description
G1312-60067	Outlet valve 1220/1260

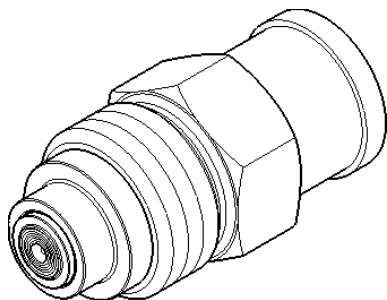

Figure 29 Outlet Valve

Purge Valve Assembly

Item	p/n	Description
1	G1312-60061	Purge valve 1260
2	01018-22707	PTFE frits (pack of 5)
3	5067-4728	Seal cap

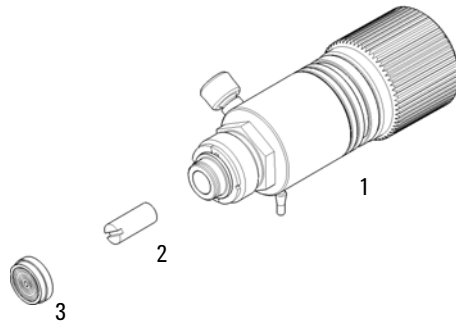

Figure 30 Purge Valve Assembly

Active Inlet Valve Assembly

Item	p/n	Description
1	G1312-60025	Active inlet valve body, without cartridge
2	G1312-60020	Cartridge for active inlet valve 600 bar

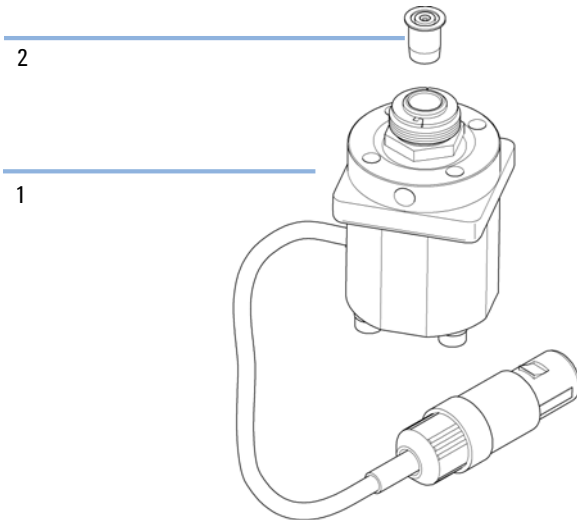

Figure 31 Active Inlet Valve Assembly

HPLC Starter Kit G4201-68707

HPLC Starter Kit incl. 0.17 mm i.d. cap (G4201-68707)

p/n	Description
9301-1420 (3x)	Solvent bottle, transparent
9301-1450	Solvent bottle, amber
01018-22707	PTFE frits (pack of 5)
5182-0716	Screw Cap Vial, 2 mL, amber glass, write-on spot, 100/pk
5182-0717	Blue screw caps 100/pk
5063-6507 (2x)	Chip, Column I.D. Assy
5041-2168 (2x)	Solvent inlet filter, 20 µm pore size
5065-9939	Capillary/Fitting Starter Kit 0.17 mm id

HPLC Starter Kit G4202-68707

HPLC Starter Kit incl. 0.12 mm i.d. cap (G4202-68707)

p/n	Description
9301-1420 (3x)	Solvent bottle, transparent
9301-1450	Solvent bottle, amber
01018-22707	PTFE frits (pack of 5)
5182-0716	Screw Cap Vial, 2 mL, amber glass, write-on spot, 100/pk
5182-0717	Blue screw caps 100/pk
5063-6507 (2x)	Chip, Column I.D. Assy
5041-2168 (2x)	Solvent inlet filter, 20 µm pore size
G1316-80003	Heater long-down (0.12 mm i.d., 1.6 µL internal volume)
5065-9937	Capillary/Fitting Starter Kit 0.12 mm id

HPLC System Tool Kit

The HPLC System Tool Kit (G4203-68708) contains some accessories and tools needed for installation and repair of the module.

p/n	Description
0100-1681	Adapter syringe/seal wash tube
0100-1710	Mounting Tool for Tubing Connections
01018-23702	Insert tool
5023-0240	Hex driver, ¼", slitted
8710-0060	Hex-key wrench, 9/64 inch
8710-0510 (2x)	Wrench open 1/4 — 5/16 inch
8710-0641	Hex key set 1 – 5 mm
8710-0899	Pozidriv screwdriver
8710-1534	Wrench, 4 mm both ends, open end
8710-1924	Wrench open 14 mm
8710-2392	Hex key 4 mm 15 cm long T-handle
8710-2393	Hex key 1.5 mm, straight handle 10 cm
8710-2394	Hex key 9/64 inch 15 cm long T-handle
8710-2409	Wrench open end, 5/16 – 3/8 inch
8710-2411	Hex key 3 mm 12 cm long
8710-2412	Hex key 2.5 mm, 15 cm long, straight handle
8710-2438	Hex key 2.0 mm
8710-2509	Screwdriver Torx TX8
8710-2594	Double open end wrench 4 mm
9301-0411	Syringe, Plastic
9301-1337	Adapter syringe/solvent tube with fitting

Bottle Head Assembly

Item	p/n	Description
1	9301-1450	Solvent bottle, amber
2	9301-1420	Solvent bottle, transparent
3	G1311-60003	Bottle-head assembly
4	5063-6598	Ferrules with lock ring (10/Pk)
5	5063-6599	Tube screw (10/Pk)
6	5062-2483	Solvent tubing, 5 m
7	5062-8517	Inlet filter adapter (4/Pk)
8	5041-2168	Solvent inlet filter, 20 µm pore size

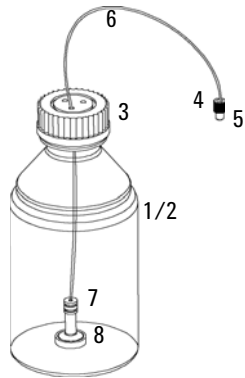

Figure 32 Bottle-Head Assembly Parts

Solvent Cabinet

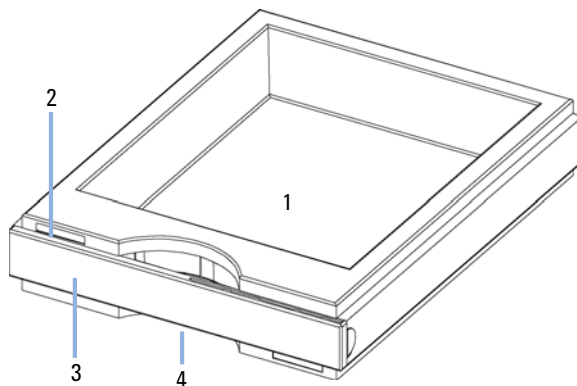

Figure 33 Solvent Cabinet Parts (1)



Figure 34 Solvent Cabinet Parts (2)

Item	p/n	Description
1	5065-9981	Solvent cabinet 1200 Infinity, including all plastic parts
2	5043-0207	Name plate 1260
3	5065-9954	Front panel, solvent cabinet
4	5042-8907	Leak panel
5	9301-1450	Solvent bottle, amber
6	9301-1420	Solvent bottle, transparent
7	G1311-60003	Bottle-head assembly

11 Parts and Materials for Maintenance

Solvent Cabinet



12 Identifying Cables

Overview	202
Analog cables	204
Remote Cables	206
BCD Cables	209
CAN/LAN Cables	211
External Contact Cables	212
RS-232 Cable Kit	213
Agilent 1200 Module to Printer	214

This chapter provides information on cables used with the Agilent 1200 Infinity Series modules.



Overview

NOTE

Never use cables other than the ones supplied by Agilent Technologies to ensure proper functionality and compliance with safety or EMC regulations.

Analog cables

p/n	Description
35900-60750	Agilent module to 3394/6 integrators
35900-60750	Agilent 35900A A/D converter
01046-60105	Analog cable (BNC to general purpose, spade lugs)

Remote cables

p/n	Description
03394-60600	Agilent module to 3396A Series I integrators 3396 Series II / 3395A integrator, see details in section " Remote Cables " on page 206
03396-61010	Agilent module to 3396 Series III / 3395B integrators
5061-3378	Remote Cable
01046-60201	Agilent module to general purpose

BCD cables

p/n	Description
03396-60560	Agilent module to 3396 integrators
G1351-81600	Agilent module to general purpose

CAN cables

p/n	Description
5181-1516	CAN cable, Agilent module to module, 0.5 m
5181-1519	CAN cable, Agilent module to module, 1 m

LAN cables

p/n	Description
5023-0203	Cross-over network cable, shielded, 3 m (for point to point connection)
5023-0202	Twisted pair network cable, shielded, 7 m (for point to point connection)

External Contact Cable

p/n	Description
G1103-61611	External contact cable - Agilent module interface board to general purposes

RS-232 cables

p/n	Description
G1530-60600	RS-232 cable, 2 m
RS232-61601	RS-232 cable, 2.5 m Instrument to PC, 9-to-9 pin (female). This cable has special pin-out, and is not compatible with connecting printers and plotters. It's also called "Null Modem Cable" with full handshaking where the wiring is made between pins 1-1, 2-3, 3-2, 4-6, 5-5, 6-4, 7-8, 8-7, 9-9.
5181-1561	RS-232 cable, 8 m

Analog cables

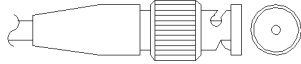

One end of these cables provides a BNC connector to be connected to Agilent modules. The other end depends on the instrument to which connection is being made.

Agilent Module to 3394/6 Integrators

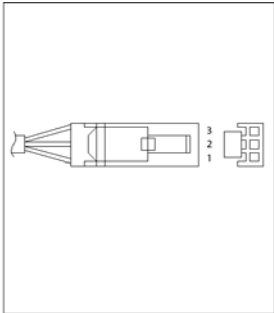
p/n 35900-60750	Pin 3394/6	Pin Agilent module	Signal Name
	1		Not connected
	2	Shield	Analog -
	3	Center	Analog +

Agilent Module to BNC Connector

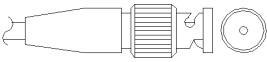
p/n 8120-1840	Pin BNC	Pin Agilent module	Signal Name
	Shield	Shield	Analog -
	Center	Center	Analog +

Agilent Module to General Purpose

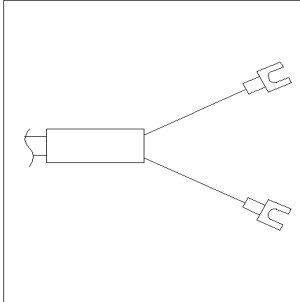
p/n 01046-60105	Pin	Pin Agilent module	Signal Name
	1		Not connected
	2	Black	Analog -
	3	Red	Analog +

Remote Cables



One end of these cables provides a Agilent Technologies APG (Analytical Products Group) remote connector to be connected to Agilent modules. The other end depends on the instrument to be connected to.

Agilent Module to 3396A Integrators

p/n 03394-60600	Pin 3396A	Pin Agilent module	Signal Name	Active (TTL)
<p>A diagram of the Agilent module connector, a vertical rectangular component with a central row of pins. Pins 1, 3, 5, 7, 9, 13, and 15 are labeled. Pin 1 is at the bottom left, pin 9 is at the bottom right, pin 15 is at the top right, and pin 8 is at the top left. A small rectangular tab is attached to the right side of the connector.</p>	9	1 - White	Digital ground	
	NC	2 - Brown	Prepare run	Low
	3	3 - Gray	Start	Low
	NC	4 - Blue	Shut down	Low
	NC	5 - Pink	Not connected	
	NC	6 - Yellow	Power on	High
	5,14	7 - Red	Ready	High
	1	8 - Green	Stop	Low
	NC	9 - Black	Start request	Low
	13, 15		Not connected	

Agilent Module to 3396 Series II / 3395A Integrators

Use the cable Agilent module to 3396A Series I integrators (03394-60600) and cut pin #5 on the integrator side. Otherwise the integrator prints START; not ready.

Agilent Module to 3396 Series III / 3395B Integrators

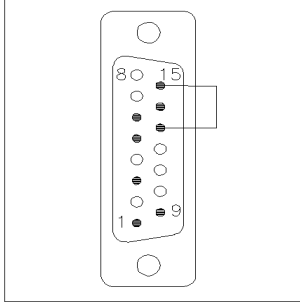
p/n 03396-61010	Pin 33XX	Pin Agilent module	Signal Name	Active (TTL)
	9	1 - White	Digital ground	
	NC	2 - Brown	Prepare run	Low
	3	3 - Gray	Start	Low
	NC	4 - Blue	Shut down	Low
	NC	5 - Pink	Not connected	
	NC	6 - Yellow	Power on	High
	14	7 - Red	Ready	High
	4	8 - Green	Stop	Low
	NC	9 - Black	Start request	Low
	13, 15		Not connected	

Agilent Module to Agilent 35900 A/D Converters

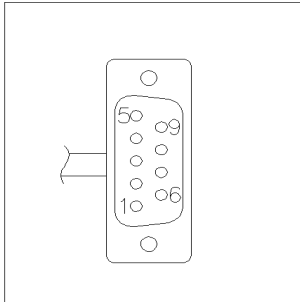
p/n 5061-3378	Pin 35900 A/D	Pin Agilent module	Signal Name	Active (TTL)
	1 - White	1 - White	Digital ground	
	2 - Brown	2 - Brown	Prepare run	Low
	3 - Gray	3 - Gray	Start	Low
	4 - Blue	4 - Blue	Shut down	Low
	5 - Pink	5 - Pink	Not connected	
	6 - Yellow	6 - Yellow	Power on	High
	7 - Red	7 - Red	Ready	High
	8 - Green	8 - Green	Stop	Low
	9 - Black	9 - Black	Start request	Low

12 Identifying Cables

Remote Cables

Agilent Module to General Purpose

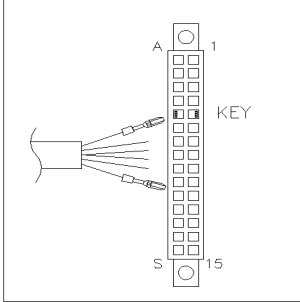
p/n 01046-60201	Wire Color	Pin Agilent module	Signal Name	Active (TTL)
	White	1	Digital ground	
	Brown	2	Prepare run	Low
	Gray	3	Start	Low
	Blue	4	Shut down	Low
	Pink	5	Not connected	
	Yellow	6	Power on	High
	Red	7	Ready	High
	Green	8	Stop	Low
	Black	9	Start request	Low

BCD Cables



One end of these cables provides a 15-pin BCD connector to be connected to the Agilent modules. The other end depends on the instrument to be connected to

Agilent Module to General Purpose

p/n G1351-81600	Wire Color	Pin Agilent module	Signal Name	BCD Digit
	Green	1	BCD 5	20
	Violet	2	BCD 7	80
	Blue	3	BCD 6	40
	Yellow	4	BCD 4	10
	Black	5	BCD 0	1
	Orange	6	BCD 3	8
	Red	7	BCD 2	4
	Brown	8	BCD 1	2
	Gray	9	Digital ground	Gray
	Gray/pink	10	BCD 11	800
	Red/blue	11	BCD 10	400
	White/green	12	BCD 9	200
	Brown/green	13	BCD 8	100
	not connected	14		
	not connected	15	+ 5 V	Low

12 Identifying Cables

BCD Cables

Agilent Module to 3396 Integrators

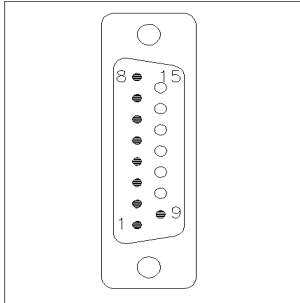
p/n 03396-60560	Pin 3396	Pin Agilent module	Signal Name	BCD Digit
	1	1	BCD 5	20
	2	2	BCD 7	80
	3	3	BCD 6	40
	4	4	BCD 4	10
	5	5	BCD0	1
	6	6	BCD 3	8
	7	7	BCD 2	4
	8	8	BCD 1	2
	9	9	Digital ground	
	NC	15	+ 5 V	Low

CAN/LAN Cables

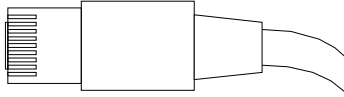

Both ends of this cable provide a modular plug to be connected to Agilent modules CAN or LAN connectors.

CAN Cables

p/n	Description
5181-1516	CAN cable, Agilent module to module, 0.5 m
5181-1519	CAN cable, Agilent module to module, 1 m

LAN Cables

p/n	Description
5023-0203	Cross-over network cable, shielded, 3 m (for point to point connection)
5023-0202	Twisted pair network cable, shielded, 7 m (for point to point connection)

External Contact Cables

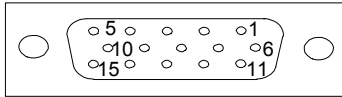

One end of this cable provides a 15-pin plug to be connected to Agilent modules interface board. The other end is for general purpose.

Agilent Module Interface Board to general purposes

p/n G1103-61611	Color	Pin Agilent module	Signal Name
	White	1	EXT 1
	Brown	2	EXT 1
	Green	3	EXT 2
	Yellow	4	EXT 2
	Grey	5	EXT 3
	Pink	6	EXT 3
	Blue	7	EXT 4
	Red	8	EXT 4
	Black	9	Not connected
	Violet	10	Not connected
	Grey/pink	11	Not connected
	Red/blue	12	Not connected
	White/green	13	Not connected
	Brown/green	14	Not connected
	White/yellow	15	Not connected

RS-232 Cable Kit

p/n	Description
G1530-60600	RS-232 cable, 2 m
RS232-61601	RS-232 cable, 2.5 m Instrument to PC, 9-to-9 pin (female). This cable has special pin-out, and is not compatible with connecting printers and plotters. It's also called "Null Modem Cable" with full handshaking where the wiring is made between pins 1-1, 2-3, 3-2, 4-6, 5-5, 6-4, 7-8, 8-7, 9-9.
5181-1561	RS-232 cable, 8 m

12 Identifying Cables

Agilent 1200 Module to Printer

Agilent 1200 Module to Printer

p/n	Description
5181-1529	Cable Printer Serial & Parallel, is a SUB-D 9 pin female vs. Centronics connector on the other end (NOT FOR FW UPDATE). For use with G1323 Control Module.



13 Hardware Information

Firmware Description	216
Electrical Connections	219
Rear view of the module	220
Interfaces	221
Overview Interfaces	224
Setting the 8-bit Configuration Switch (without On-board) LAN	228
Communication Settings for RS-232C	229
Special Settings	231
Optional Interface Boards	232
The Solvent Selection Valve (SSV)	236
Early Maintenance Feedback	237
Instrument Layout	238

This chapter provides detailed technical information about your binary pump.



Firmware Description

The firmware of the instrument consists of two independent sections:

- a non-instrument specific section, called *resident system*
- an instrument specific section, called *main system*

Resident System

This resident section of the firmware is identical for all Agilent 1100/1200/1220/1260/1290 series modules. Its properties are:

- the complete communication capabilities (CAN, LAN and RS-232C)
- memory management
- ability to update the firmware of the 'main system'

Main System

Its properties are:

- the complete communication capabilities (CAN, LAN and RS-232C)
- memory management
- ability to update the firmware of the 'resident system'

In addition the main system comprises the instrument functions that are divided into common functions like

- run synchronization through APG remote,
- error handling,
- diagnostic functions,
- or module specific functions like
 - internal events such as lamp control, filter movements,
 - raw data collection and conversion to absorbance.

Firmware Updates

Firmware updates can be done using your user interface:

- PC and Firmware Update Tool with local files on the hard disk
- Instant Pilot (G4208A) with files from a USB Flash Disk
- Agilent Lab Advisor software B.01.03 and above

The file naming conventions are:

PPPP_RVVV_XXX.dlb, where

PPPP is the product number, for example, 1315AB for the G1315A/B DAD,

R the firmware revision, for example, A for G1315B or B for the G1315C DAD,

VVV is the revision number, for example 102 is revision 1.02,

XXX is the build number of the firmware.

For instructions on firmware updates refer to section *Replacing Firmware* in chapter "Maintenance" or use the documentation provided with the *Firmware Update Tools*.

NOTE

Update of main system can be done in the resident system only. Update of the resident system can be done in the main system only.

Main and resident firmware must be from the same set.

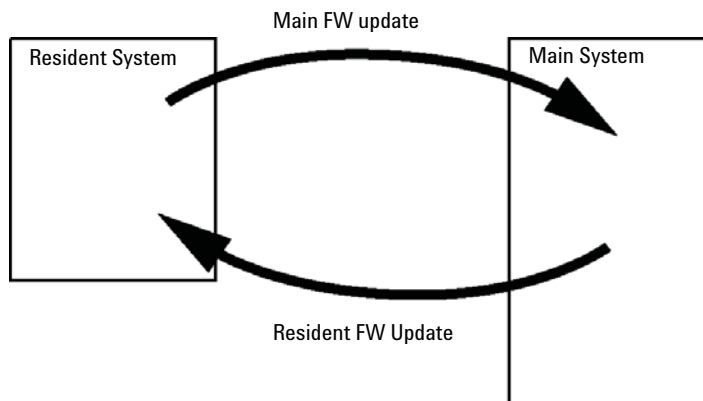

Figure 35 Firmware Update Mechanism

13 Hardware Information

Firmware Description

NOTE

Some modules are limited in downgrading due to their main board version or their initial firmware revision. For example, a G1315C DAD SL cannot be downgraded below firmware revision B.01.02 or to a A.xx.xx.

Some modules can be re-branded (e.g. G1314C to G1314B) to allow operation in specific control software environments. In this case the feature set of the target type are use and the feature set of the original are lost. After re-branding (e.g. from G1314B to G1314C), the original feature set is available again.

All these specific informations are described in the documentation provided with the firmware update tools.

The firmware update tools, firmware and documentation are available from the Agilent web.

- http://www.chem.agilent.com/_layouts/agilent/downloadFirmware.aspx?whid=69761

Electrical Connections

- The CAN bus is a serial bus with high speed data transfer. The two connectors for the CAN bus are used for internal module data transfer and synchronization.
- One analog output provides signals for integrators or data handling systems.
- The interface board slot is used for external contacts and BCD bottle number output or LAN connections.
- The REMOTE connector may be used in combination with other analytical instruments from Agilent Technologies if you want to use features such as start, stop, common shut down, prepare, and so on.
- With the appropriate software, the RS-232C connector may be used to control the module from a computer through a RS-232C connection. This connector is activated and can be configured with the configuration switch.
- The power input socket accepts a line voltage of 100 – 240 VAC \pm 10 % with a line frequency of 50 or 60 Hz. Maximum power consumption varies by module. There is no voltage selector on your module because the power supply has wide-ranging capability. There are no externally accessible fuses, because automatic electronic fuses are implemented in the power supply.

NOTE

Never use cables other than the ones supplied by Agilent Technologies to ensure proper functionality and compliance with safety or EMC regulations.

Rear view of the module

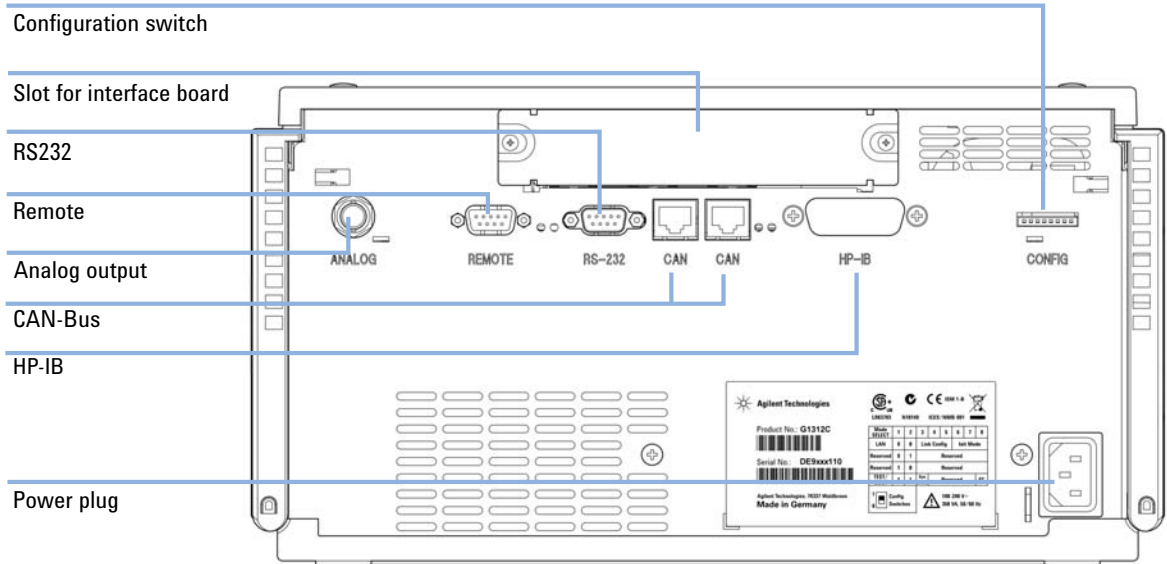

Figure 36 Electrical connections to the binary pump

Interfaces

The Agilent 1200 Infinity Series modules provide the following interfaces:

Table 14 Agilent 1200 Infinity Series Interfaces

Module	CAN	LAN/BCD (optional)	LAN (on-board)	RS-232	Analog	APG Remote	Special
Pumps							
G1310B Iso Pump G1311B Quat Pump G1311C Quat Pump VL G1312B Bin Pump K1312B Bin Pump Clinical Ed. G1312C Bin Pump VL 1376A Cap Pump G2226A Nano Pump G5611A Bio-inert Quat Pump	2	Yes	No	Yes	1	Yes	
G4220A/B Bin Pump G4204A Quat Pump	2	No	Yes	Yes	No	Yes	CAN-DC- OUT for CAN slaves
G1361A Prep Pump	2	Yes	No	Yes	No	Yes	CAN-DC- OUT for CAN slaves
Samplers							
G1329B ALS G2260A Prep ALS	2	Yes	No	Yes	No	Yes	THERMOSTAT for G1330B/K1330B
G1364B FC-PS G1364C FC-AS G1364D FC- μ S G1367E HiP ALS K1367E HiP ALS Clinical Ed. G1377A HiP micro ALS G2258A DL ALS G5664A Bio-inert FC-AS G5667A Bio-inert Autosampler	2	Yes	No	Yes	No	Yes	THERMOSTAT for G1330B/K1330B CAN-DC- OUT for CAN slaves
G4226A ALS	2	Yes	No	Yes	No	Yes	

13 Hardware Information

Interfaces

Table 14 Agilent 1200 Infinity Series Interfaces

Module	CAN	LAN/BCD (optional)	LAN (on-board)	RS-232	Analog	APG Remote	Special
Detectors							
G1314B VWD VL G1314C VWD VL+	2	Yes	No	Yes	1	Yes	
G1314E/F VWD K1314F Clinical Ed.	2	No	Yes	Yes	1	Yes	
G4212A/B DAD K4212B DAD Clinical Ed.	2	No	Yes	Yes	1	Yes	
G1315C DAD VL+ G1365C MWD G1315D DAD VL G1365D MWD VL	2	No	Yes	Yes	2	Yes	
G1321B FLD K1321B FLD Clinical Ed. G1321C FLD	2	Yes	No	Yes	2	Yes	
G1362A RID	2	Yes	No	Yes	1	Yes	
G4280A ELSD	No	No	No	Yes	Yes	Yes	EXT Contact AUTOZERO
Others							
G1170A Valve Drive	2	No	No	No	No	No	1
G1316A/C TCC K1316C TCC Clinical Ed.	2	No	No	Yes	No	Yes	
G1322A DEG K1322A DEG Clinical Ed.	No	No	No	No	No	Yes	AUX
G1379B DEG	No	No	No	Yes	No	Yes	
G4225A DEG K4225A DEG Clinical Ed.	No	No	No	Yes	No	Yes	

Table 14 Agilent 1200 Infinity Series Interfaces

Module	CAN	LAN/BCD (optional)	LAN (on-board)	RS-232	Analog	APG Remote	Special
G4227A Flex Cube	2	No	No	No	No	No	CAN-DC- OUT for CAN slaves 1
G4240A CHIP CUBE	2	Yes	No	Yes	No	Yes	CAN-DC- OUT for CAN slaves THERMOSTAT for G1330A/B (NOT USED), K1330B

¹ Requires a HOST module with on-board LAN (e.g. G4212A or G4220A with minimum firmware B.06.40 or C.06.40) or with additional G1369C LAN Card

NOTE

The detector (DAD/MWD/FLD/VWD/RID) is the preferred access point for control via LAN. The inter-module communication is done via CAN.

- CAN connectors as interface to other modules
- LAN connector as interface to the control software
- RS-232C as interface to a computer
- REMOTE connector as interface to other Agilent products
- Analog output connector(s) for signal output

Overview Interfaces

CAN

The CAN is inter-module communication interface. It is a 2-wire serial bus system supporting high speed data communication and real-time requirement.

LAN

The modules have either an interface slot for an LAN card (e.g. Agilent G1369B/C LAN Interface) or they have an on-board LAN interface (e.g. detectors G1315C/D DAD and G1365C/D MWD). This interface allows the control of the module/system via a PC with the appropriate control software. Some modules have neither on-board LAN nor an interface slot for a LAN card (e.g. G1170A Valve Drive or G4227A Flex Cube). These are hosted modules and require a Host module with firmware B.06.40 or later or with additional G1369C LAN Card.

NOTE

If an Agilent detector (DAD/MWD/FLD/VWD/RID) is in the system, the LAN should be connected to the DAD/MWD/FLD/VWD/RID (due to higher data load). If no Agilent detector is part of the system, the LAN interface should be installed in the pump or autosampler.

RS-232C (Serial)

The RS-232C connector is used to control the module from a computer through RS-232C connection, using the appropriate software. This connector can be configured with the configuration switch module at the rear of the module. Refer to *Communication Settings for RS-232C*.

NOTE

There is no configuration possible on main boards with on-board LAN. These are pre-configured for

- 19200 baud,
 - 8 data bit with no parity and
 - one start bit and one stop bit are always used (not selectable).
-

The RS-232C is designed as DCE (data communication equipment) with a 9-pin male SUB-D type connector. The pins are defined as:

Table 15 RS-232C Connection Table

Pin	Direction	Function
1	In	DCD
2	In	RxD
3	Out	TxD
4	Out	DTR
5		Ground
6	In	DSR
7	Out	RTS
8	In	CTS
9	In	RI

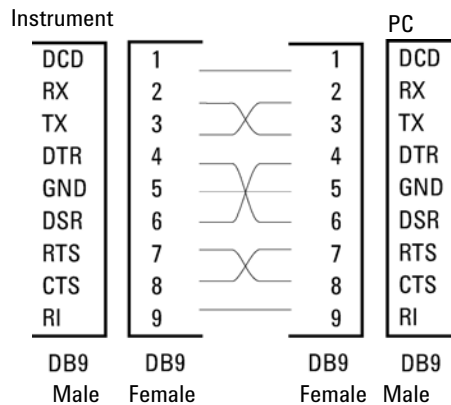

Figure 37 RS-232 Cable

Analog Signal Output

The analog signal output can be distributed to a recording device. For details refer to the description of the module's main board.

APG Remote

The APG Remote connector may be used in combination with other analytical instruments from Agilent Technologies if you want to use features as common shut down, prepare, and so on.

Remote control allows easy connection between single instruments or systems to ensure coordinated analysis with simple coupling requirements.

The subminiature D connector is used. The module provides one remote connector which is inputs/outputs (wired- or technique).

To provide maximum safety within a distributed analysis system, one line is dedicated to **SHUT DOWN** the system's critical parts in case any module detects a serious problem. To detect whether all participating modules are switched on or properly powered, one line is defined to summarize the **POWER ON** state of all connected modules. Control of analysis is maintained by signal readiness **READY** for next analysis, followed by **START** of run and optional **STOP** of run triggered on the respective lines. In addition **PREPARE** and **START REQUEST** may be issued. The signal levels are defined as:

- standard TTL levels (0 V is logic true, + 5.0 V is false),
- fan-out is 10 ,
- input load is 2.2 kOhm against + 5.0 V, and
- output are open collector type, inputs/outputs (wired- or technique).

NOTE

All common TTL circuits operate with a 5 V power supply. A TTL signal is defined as "low" or L when between 0 V and 0.8 V and "high" or H when between 2.0 V and 5.0 V (with respect to the ground terminal).

Table 16 Remote Signal Distribution

Pin	Signal	Description
1	DGND	Digital ground
2	PREPARE	(L) Request to prepare for analysis (for example, calibration, detector lamp on). Receiver is any module performing pre-analysis activities.
3	START	(L) Request to start run / timetable. Receiver is any module performing run-time controlled activities.
4	SHUT DOWN	(L) System has serious problem (for example, leak: stops pump). Receiver is any module capable to reduce safety risk.
5		Not used
6	POWER ON	(H) All modules connected to system are switched on. Receiver is any module relying on operation of others.
7	READY	(H) System is ready for next analysis. Receiver is any sequence controller.
8	STOP	(L) Request to reach system ready state as soon as possible (for example, stop run, abort or finish and stop injection). Receiver is any module performing run-time controlled activities.
9	START REQUEST	(L) Request to start injection cycle (for example, by start key on any module). Receiver is the autosampler.

Special Interfaces

There is no special interface for this module.

13 Hardware Information

Setting the 8-bit Configuration Switch (without On-board) LAN

Setting the 8-bit Configuration Switch (without On-board) LAN

The 8-bit configuration switch is located at the rear of the module.

This module does not have its own on-board LAN interface. It can be controlled through the LAN interface of another module, and a CAN connection to that module.

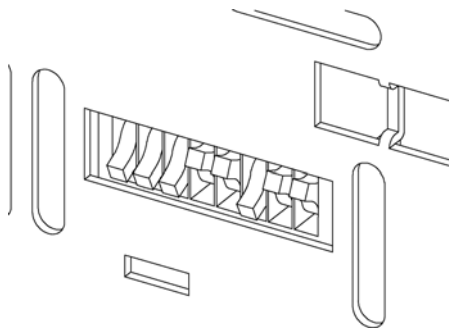

Figure 38 Configuration switch (settings depend on configured mode)

All modules without on-board LAN:

- default should be ALL DIPS DOWN (= best settings)
 - Bootp mode for LAN and
 - 19200 baud, 8 data bit / 1 stop bit with no parity for RS-232
- DIP 1 DOWN and DIP 2 UP allows special RS-232 settings
- for boot/test modes DIPS 1+2 must be UP plus required mode

NOTE

For normal operation use the default (best) settings.

Switch settings provide configuration parameters for serial communication protocol and instrument specific initialization procedures.

NOTE

With the introduction of the Agilent 1260 Infinity, all GPIB interfaces have been removed. The preferred communication is LAN.

NOTE

The following tables represent the configuration switch settings for the modules without on-board LAN only.

Table 17 8-bit Configuration Switch (without on-board LAN)

Mode Select	1	2	3	4	5	6	7	8
RS-232C	0	1	Baudrate			Data Bits	Parity	
Reserved	1	0	Reserved					
TEST/BOOT	1	1	RSVD	SYS		RSVD	RSVD	FC

NOTE

The LAN settings are done on the LAN Interface Card G1369B/C. Refer to the documentation provided with the card.

Communication Settings for RS-232C

The communication protocol used in the column compartment supports only hardware handshake (CTS/RTR).

Switches 1 in down and 2 in up position define that the RS-232C parameters will be changed. Once the change has been completed, the column instrument must be powered up again in order to store the values in the non-volatile memory.

Table 18 Communication Settings for RS-232C Communication (without on-board LAN)

Mode Select	1	2	3	4	5	6	7	8
RS-232C	0	1	Baudrate			Data Bits	Parity	

Use the following tables for selecting the setting which you want to use for RS-232C communication. The number 0 means that the switch is down and 1 means that the switch is up.

13 Hardware Information

Setting the 8-bit Configuration Switch (without On-board) LAN

Table 19 Baudrate Settings (without on-board LAN)

Switches			Baud Rate	Switches			Baud Rate
3	4	5		3	4	5	
0	0	0	9600	1	0	0	9600
0	0	1	1200	1	0	1	14400
0	1	0	2400	1	1	0	19200
0	1	1	4800	1	1	1	38400

Table 20 Data Bit Settings (without on-board LAN)

Switch 6	Data Word Size
0	7 Bit Communication
1	8 Bit Communication

Table 21 Parity Settings (without on-board LAN)

Switches		Parity
7	8	
0	0	No Parity
0	1	Odd Parity
1	1	Even Parity

One start bit and one stop bit are always used (not selectable).

Per default, the module will turn into 19200 baud, 8 data bit with no parity.

Special Settings

The special settings are required for specific actions (normally in a service case).

Boot-Resident

Firmware update procedures may require this mode in case of firmware loading errors (main firmware part).

If you use the following switch settings and power the instrument up again, the instrument firmware stays in the resident mode. It is not operable as a module. It only uses basic functions of the operating system for example, for communication. In this mode the main firmware can be loaded (using update utilities).

Table 22 Boot Resident Settings (without on-board LAN)

Mode Select	SW1	SW2	SW3	SW4	SW5	SW6	SW7	SW8
TEST/BOOT	1	1	0	0	1	0	0	0

Forced Cold Start

A forced cold start can be used to bring the module into a defined mode with default parameter settings.

CAUTION

Loss of data

Forced cold start erases all methods and data stored in the non-volatile memory. Exceptions are calibration settings, diagnosis and repair log books which will not be erased.

→ Save your methods and data before executing a forced cold start.

If you use the following switch settings and power the instrument up again, a forced cold start has been completed.

Table 23 Forced Cold Start Settings (without on-board LAN)

Mode Select	SW1	SW2	SW3	SW4	SW5	SW6	SW7	SW8
TEST/BOOT	1	1	0	0	0	0	0	1

Optional Interface Boards

BCD / External Contact Board

The Agilent 1200 Infinity Series modules have one optional board slot that allows to add an interface board to the modules. Some modules do not have this interface slot. Refer to “Interfaces” on page 221 for details.

Optional Interface Boards

p/n	Description
G1351-68701	Interface board (BCD) with external contacts and BCD outputs
2110-0004	Fuse for BCD board, 250 mA

The BCD board provides a BCD output for the bottle number of the Agilent 1200 Series autosampler and four external contacts. The external contact closure contacts are relay contacts. The maximum settings are: 30 V (AC/DC); 250 mA (fused).

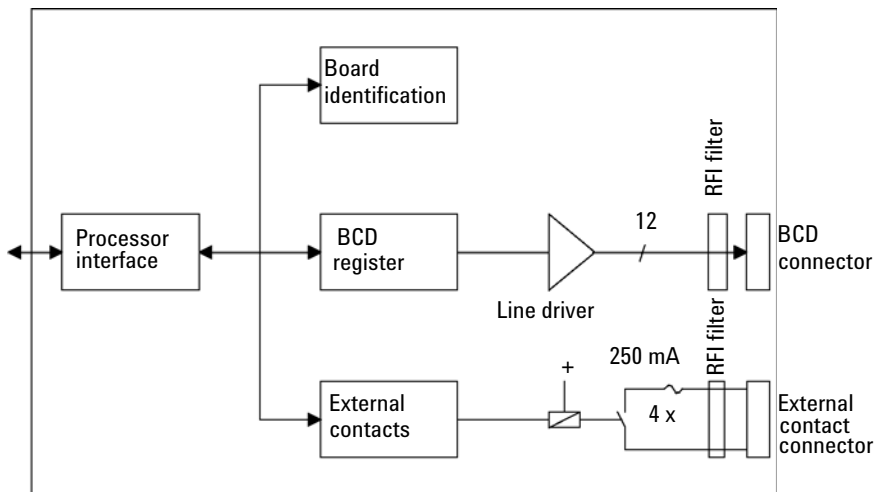

There are general purpose cables available to connect the BCD output, see “[BCD Cables](#)” on page 209 and the external outputs, see “[External Contact Cables](#)” on page 212 to external devices.

Table 24 Detailed connector layout (1200)

Pin	Signal name	BCD digit
1	BCD 5	20
2	BCD 7	80
3	BCD 6	40
4	BCD 4	10
5	BCD 0	1
6	BCD 3	8
7	BCD 2	4
8	BCD 1	2
9	Digital ground	
10	BCD 11	800
11	BCD 10	400
12	BCD 9	200
13	BCD 8	100
15	+5V	Low

LAN Communication Interface Board

The Agilent modules have one optional board slot that allows to add an interface board to the modules. Some modules do not have this interface slot. Refer to “[Interfaces](#)” on page 221 for details.

p/n	Description
G1369B or G1369-60002	Interface board (LAN)
OR G1369C or G1369-60012	Interface board (LAN)

NOTE

One board is required per Agilent 1260 Infinity instrument. It is recommended to add the LAN board to the detector with highest data rate.

NOTE

For the configuration of the G1369 LAN Communication Interface card refer to its documentation.

The following cards can be used with the Agilent 1260 Infinity modules.

Table 25 LAN Boards

Type	Vendor	Supported networks
Interface board (LAN) (G1369B or G1369-60002) or Interface board (LAN) (G1369C or G1369-60012)	Agilent Technologies	Fast Ethernet, Ethernet/802.3, RJ-45 (10/100Base-TX) <i>recommended for re-ordering</i>
LAN Communication Interface board (G1369A or G1369-60001)	Agilent Technologies	Fast Ethernet, Ethernet/802.3, RJ-45 (10/100Base-TX) <i>(obsolete)</i>
J4106A ¹	Hewlett Packard	Ethernet/802.3, RJ-45 (10Base-T)
J4105A ¹	Hewlett Packard	Token Ring/802.5, DB9, RJ-45 (10Base-T)
J4100A ¹	Hewlett Packard	Fast Ethernet, Ethernet/802.3, RJ-45 (10/100Base-TX) + BNC (10Base2)

¹ These cards may be no longer orderable. Minimum firmware of these Hewlett Packard JetDirect cards is A.05.05.

Recommended LAN Cables

p/n	Description
5023-0203	Cross-over network cable, shielded, 3 m (for point to point connection)
5023-0202	Twisted pair network cable, shielded, 7 m (for point to point connection)

The Solvent Selection Valve (SSV)

The solvent selection valve is available optionally and as an upgrade. It allows using four different solvents for binary pumps. The available channels are A1/A2 and B1/B2. The valve can switch between positions 1 and 2, i.e. two different solvents are available per channel. It is not possible to switch for example between A1 and B1 for channel B, as solvent paths A and B are completely separated. By cascading SSV channels, for example using inlets A1 and A2 and connecting the outlet of channel A to inlet B1, it is possible to switch between three (A1/A2/B2) solvents for one channel (here: B) and using always the same solvent for channel A.

Technically, the 1260 Infinity SSV uses two electromagnetic valves. If the current is off, inlets A2 and B2 are connected to the outlet. If the current is on, the valves switch to A1 and/or B1. This means, if the pump is switched off physically, solvent connections use inlets A2 and B2. If the pump is in standby (for example after using the Off button in ChemStation), the SSV retains its previous state.

Unused channels of an SSV should always be blocked using a plug (Blank plug (5041-8365)) in order to avoid leaks or air entering the solvent channels.

Early Maintenance Feedback

Maintenance requires the exchange of components which are subject to wear or stress. Ideally, the frequency at which components are exchanged should be based on the intensity of usage of the module and the analytical conditions, and not on a predefined time interval. The early maintenance feedback (**EMF**) feature monitors the usage of specific components in the instrument, and provides feedback when the user-selectable limits have been exceeded. The visual feedback in the user interface provides an indication that maintenance procedures should be scheduled.

EMF Counters

EMF counters increment with use and can be assigned a maximum limit which provides visual feedback in the user interface when the limit is exceeded. Some counters can be reset to zero after the required maintenance procedure.

Using the EMF Counters

The user-settable **EMF** limits for the **EMF Counters** enable the early maintenance feedback to be adapted to specific user requirements. The useful maintenance cycle is dependent on the requirements for use. Therefore, the definition of the maximum limits need to be determined based on the specific operating conditions of the instrument.

Setting the EMF Limits

The setting of the **EMF** limits must be optimized over one or two maintenance cycles. Initially the default **EMF** limits should be set. When instrument performance indicates maintenance is necessary, take note of the values displayed by the **EMF counters**. Enter these values (or values slightly less than the displayed values) as **EMF** limits, and then reset the **EMF counters** to zero. The next time the **EMF counters** exceed the new **EMF** limits, the **EMF** flag will be displayed, providing a reminder that maintenance needs to be scheduled.

Instrument Layout

The industrial design of the module incorporates several innovative features. It uses Agilent's E-PAC concept for the packaging of electronics and mechanical assemblies. This concept is based upon the use of expanded polypropylene (EPP) layers of foam plastic spacers in which the mechanical and electronic boards components of the module are placed. This pack is then housed in a metal inner cabinet which is enclosed by a plastic external cabinet. The advantages of this packaging technology are:

- virtual elimination of fixing screws, bolts or ties, reducing the number of components and increasing the speed of assembly/disassembly,
- the plastic layers have air channels molded into them so that cooling air can be guided exactly to the required locations,
- the plastic layers help cushion the electronic and mechanical parts from physical shock, and
- the metal inner cabinet shields the internal electronics from electromagnetic interference and also helps to reduce or eliminate radio frequency emissions from the instrument itself.



14 Appendix

General Safety Information	240
The Waste Electrical and Electronic Equipment Directive	243
Lithium Batteries Information	244
Radio Interference	245
Sound Emission	246
Agilent Technologies on the Internet	247





This appendix provides general safety and environmental information.



General Safety Information

Safety Symbols

Table 26 Safety Symbols

Symbol	Description
	The apparatus is marked with this symbol when the user should refer to the instruction manual in order to protect risk of harm to the operator and to protect the apparatus against damage.
	Indicates dangerous voltages.
	Indicates a protected ground terminal.
	Indicates eye damage may result from directly viewing the light produced by the deuterium lamp used in this product.
	The apparatus is marked with this symbol when hot surfaces are available and the user should not touch it when heated up.

WARNING

A WARNING

alerts you to situations that could cause physical injury or death.

- Do not proceed beyond a warning until you have fully understood and met the indicated conditions.

CAUTION

A CAUTION

alerts you to situations that could cause loss of data, or damage of equipment.

- Do not proceed beyond a caution until you have fully understood and met the indicated conditions.

General Safety Information

The following general safety precautions must be observed during all phases of operation, service, and repair of this instrument. Failure to comply with these precautions or with specific warnings elsewhere in this manual violates safety standards of design, manufacture, and intended use of the instrument. Agilent Technologies assumes no liability for the customer's failure to comply with these requirements.

WARNING

Ensure the proper usage of the equipment.

The protection provided by the equipment may be impaired.

→ The operator of this instrument is advised to use the equipment in a manner as specified in this manual.

Safety Standards

This is a Safety Class I instrument (provided with terminal for protective earthing) and has been manufactured and tested according to international safety standards.

Operation

Before applying power, comply with the installation section. Additionally the following must be observed.

Do not remove instrument covers when operating. Before the instrument is switched on, all protective earth terminals, extension cords, auto-transformers, and devices connected to it must be connected to a protective earth via a ground socket. Any interruption of the protective earth grounding will cause a potential shock hazard that could result in serious personal injury. Whenever it is likely that the protection has been impaired, the instrument must be made inoperative and be secured against any intended operation.

Make sure that only fuses with the required rated current and of the specified type (normal blow, time delay, and so on) are used for replacement. The use of repaired fuses and the short-circuiting of fuse holders must be avoided.

Some adjustments described in the manual, are made with power supplied to the instrument, and protective covers removed. Energy available at many points may, if contacted, result in personal injury.

Any adjustment, maintenance, and repair of the opened instrument under voltage should be avoided whenever possible. When inevitable, this has to be carried out by a skilled person who is aware of the hazard involved. Do not attempt internal service or adjustment unless another person, capable of rendering first aid and resuscitation, is present. Do not replace components with power cable connected.

Do not operate the instrument in the presence of flammable gases or fumes. Operation of any electrical instrument in such an environment constitutes a definite safety hazard.

Do not install substitute parts or make any unauthorized modification to the instrument.

Capacitors inside the instrument may still be charged, even though the instrument has been disconnected from its source of supply. Dangerous voltages, capable of causing serious personal injury, are present in this instrument. Use extreme caution when handling, testing and adjusting.

When working with solvents, observe appropriate safety procedures (for example, goggles, safety gloves and protective clothing) as described in the material handling and safety data sheet by the solvent vendor, especially when toxic or hazardous solvents are used.

The Waste Electrical and Electronic Equipment Directive

Abstract

The Waste Electrical and Electronic Equipment (WEEE) Directive (2002/96/EC), adopted by EU Commission on 13 February 2003, is introducing producer responsibility on all electric and electronic appliances starting with 13 August 2005.

NOTE

This product complies with the WEEE Directive (2002/96/EC) marking requirements. The affixed label indicates that you must not discard this electrical/electronic product in domestic household waste.

Product Category:

With reference to the equipment types in the WEEE Directive Annex I, this product is classed as a Monitoring and Control Instrumentation product.



NOTE

Do not dispose off in domestic household waste

To return unwanted products, contact your local Agilent office, or see www.agilent.com for more information.

Lithium Batteries Information

WARNING

Lithium batteries may not be disposed-off into the domestic waste. Transportation of discharged Lithium batteries through carriers regulated by IATA/ICAO, ADR, RID, IMDG is not allowed.

Danger of explosion if battery is incorrectly replaced.

- Discharged Lithium batteries shall be disposed off locally according to national waste disposal regulations for batteries.
- Replace only with the same or equivalent type recommended by the equipment manufacturer.



WARNING

Lithiumbatteri - Eksplosionsfare ved fejlagtig håndtering.

Udskiftning må kun ske med batteri af samme fabrikat og type.

- Lever det brugte batteri tilbage til leverandøren.

WARNING

Lithiumbatteri - Eksplosionsfare.

Ved udskiftning benyttes kun batteri som anbefalt av apparatfabrikanten.

- Brukt batteri returneres apparatleverandøren.

NOTE

Bij dit apparaat zijn batterijen geleverd. Wanneer deze leeg zijn, moet u ze niet weggooien maar inleveren als KCA.

Radio Interference

Cables supplied by Agilent Technologies are screened to provide optimized protection against radio interference. All cables are in compliance with safety or EMC regulations.

Test and Measurement

If test and measurement equipment is operated with unscreened cables, or used for measurements on open set-ups, the user has to assure that under operating conditions the radio interference limits are still met within the premises.

Sound Emission

Manufacturer's Declaration

This statement is provided to comply with the requirements of the German Sound Emission Directive of 18 January 1991.

This product has a sound pressure emission (at the operator position) < 70 dB.

- Sound Pressure $L_p < 70$ dB (A)
- At Operator Position
- Normal Operation
- According to ISO 7779:1988/EN 27779/1991 (Type Test)

Agilent Technologies on the Internet

For the latest information on products and services visit our worldwide web site on the Internet at:

<http://www.agilent.com>

Index

8

- 8-bit configuration switch
 - without On-Board LAN 228

A

- absorber capillary 14
- active inlet valve 194
- active seal wash 10, 81
- adapter 52
- Agilent Lab Advisor software 97
- Agilent Lab Advisor 97, 128
- Agilent
 - on internet 247
- AIV fuse 113
- algae growth 76
- algae 61
- alternative seal material 82
- ambient non-operating temperature 25
- ambient operating temperature 25
- analog signal output 27
- analog signal 225
- analog
 - cable 204
- apg remote 226
- assembly
 - bottle head 197
- AUTO mode 17

B

- ball-screw drive 13
- battery
 - safety information 244
- BCD board

- external contacts 232
- BCD
 - board 180
 - cable 209
- bench space 24
- blockage 116
- board
 - HP JetDirect card 234
- boards
 - LAN card 234
- bottle head assembly 197, 197
- buffer application 61
- buffer solutions 10

C

- cable
 - analog 204
 - BCD 209
 - CAN 211
 - external contact 212
 - interface 47
 - LAN 211
 - remote 206
 - RS-232 213
- cables
 - analog 202
 - BCD 202
 - CAN 203
 - external contact 203
 - LAN 203
 - overview 202
 - remote 202
 - RS-232 203
- CAN
 - cable 211

- capillary
 - absorber 14
- changing solvents 57
- cleaning 151
- Communication settings
 - RS-232C 229
- compensation sensor open 106
- compensation sensor short 107
- compensation, compressibility 26
- composition accuracy 27
- composition precision 27
- composition range 27
- composition ripple 133
- compressibility calibration 133
- compressibility compensation 26, 87
- condensation 24
- configuration
 - low flow rates 61
- connections
 - flow 51, 48
- control and data evaluation 27

D

- damaged parts 31
- damper
 - when to remove 84
- data evaluation and control 27
- defect on arrival 30
- delay volume 26, 84
- delivery checklist 31
- design 11
- diagnostic signals 93
- dimensions 25
- dual-piston in-series design 11

E

electrical connections
 descriptions of 219

electronic fuse of SSV open 113

electronic waste 243

electrostatic discharge (ESD) 180

EMF
 early maintenance feedback 237

encoder missing 117

error messages
 AIV fuse 113
 compensation sensor open 106
 compensation sensor short 107
 electronic fuse of SSV open 113
 encoder missing 117
 fan failed 107
 ignition without cover 108, 108
 index adjustment 121
 index limit 120
 index missing 122
 initialization failed 123
 inlet-valve missing 117
 leak sensor open 105
 leak sensor short 106
 leak 105
 lost CAN partner 104
 missing pressure reading 112
 motor-drive power 116
 overpressure 128, 134, 132, 136
 pressure above upper limit 109
 pressure below lower limit 110
 pressure signal missing 110
 pump head missing 119
 remote timeout 104
 servo restart failed 118
 shutdown 103
 stroke length 122
 temperature limit exceeded 115
 temperature out of range 114
 timeout 102

valve failed 111
 wrong pump configuration 112

error

solvent zero counter 109

exchanging

inlet valve 153
 interface board 180
 outlet valve sieve 153, 173
 outlet valve 153, 173
 pistons 153, 153
 pump seals 153
 purge valve frit 153
 purge valve 153
 solvent selection valve 153, 177
 wash seals 153

external contact

cable 212

external contacts

BCD board 232

F

fan failed 107

filter

solvent inlet 61

firmware

description 216
 main system 216
 resident system 216
 update tool 217
 updates 217, 181, 181
 upgrade/downgrade 181
 upgrade/downgrade 181

flow accuracy 26

flow connections 48, 51

flow precision 26

flow range 10

operational 26

setable 26

flow rate

minimum 61

frequency range 25

G

gas solubility 61

gradient formation 26

H

high-pressure mixing 10

hints for successful use 61

HP JetDirect card 234

humidity 25

hydraulic path with solvent selection
 valve 184

hydraulic path without solvent selection
 valve 186

hydraulic system 26

I

index adjustment 121

index limit 120

index missing 122

initialization failed 123

initialization 14

injection precision 80

inlet valve body 153

inlet-valve missing 117

installation

bench space 24

instrument layout 238

interface board 180

interface cable 47

interfaces 221

internet 247

introduction to the pump 10

L

LAN

cable 211

Index

- communication interface board 234
- leak rate test
 - evaluating results 140
 - potential causes of failure 141
 - running the test 139
- leak sensor open 105
- leak sensor short 106
- leak 105
- line frequency 25
- line voltage 25
- liquimeter 162
- lithium batteries 244
- lost CAN partner 104

M

- main assemblies, overview 152
- maintenance
 - feedback 237
 - pump head with seal wash 153
 - pump head without seal wash 153
 - replacing firmware 181, 181
- message
 - ignition without cover 108, 108
 - remote timeout 104
- minimum flow rate 61
- missing parts 31
- missing pressure reading 112
- mixer 11
 - when to remove 84
- motor-drive power 116

N

- non-operating altitude 25
- non-operating temperature 25

O

- operating Altitude 25
- operating temperature 25

- outlet valve 153, 173, 192
- overpressure error 128, 132, 134, 136

P

- packaging
 - damaged 30
- parts identification
 - cables 201
- parts
 - active inlet valve 194
 - bottle head assembly 197
 - damaged 31
 - hydraulic path with solvent selection valve 184
 - hydraulic path without solvent selection valve 186
 - missing 31
 - outlet valve 192
 - system tool kit 196
- performance
 - specifications 26
- pH range 26
- physical specifications 25
- piston 13
- power consideration 22
- power consumption 25
- power cords 23
- power supply indicator 94
- power switch 46
- pressure above upper limit 109
- pressure below lower limit 110
- pressure pulsation 17, 88
- pressure range 82
- pressure ripple 133
- pressure signal missing 110
- pressure test 92
 - results 132
- pressure
 - operating range 26

- pulsation 26
- priming
 - with a pump 56
- PTFE frit 153
- pulsation
 - pressure 17
- pump elasticity calibration 93, 136
- pump head assembly 153
- pump head missing 119
- pump head 153, 153
- pump seals
 - alternative material 82
 - for normal phase solvents 82
- purge valve 61, 153

R

- radio interference 245
- reassembling the pump head 167
- recommended pH range 26
- remote
 - cable 206
- remove damper and mixer 84
- removing the pump head 157
- removing
 - pump head assembly 153
- repair procedures 153
- repairs
 - definition of 148
 - introduction 148
 - replacing firmware 181, 181
 - warnings and cautions 148
- results
 - pressure test 132, 129
- ripple
 - composition 133
 - pressure 133
- RS-232C
 - cable 213
 - communication settings 229

S

safety class I 241
 safety information
 lithium batteries 244
 safety
 general information 241
 standards 25
 symbols 240
 sapphire piston 13
 seal wash
 wash solvent 81
 when to use 81
 seal wear counter 162
 seals
 alternative material 82
 normal phase 82
 servo restart failed 118
 setable flow range 26
 shutdown 103
 sieve 153, 173
 simple repair procedures 153
 site requirements 21
 power cords 23
 snap fastener 48, 51
 solubility, gas 61
 solvent cabinet 49, 61
 solvent calibration 133
 solvent compressibility calibration 93, 134
 solvent filters
 checking 77
 cleaning 77
 prevent blocking 76
 solvent inlet filter 61
 solvent selection valve 10, 48, 153, 177
 solvent zero counter 109
 solvents, change 57
 sound emission 246

special interfaces 227
 special settings
 boot-resident 231
 forced cold start 231
 specification
 physical 25
 specifications
 analog signal output 27
 communications 27
 control and data evaluation 27
 performance 26
 stack configuration
 low delay volume with post column cooler 38
 low delay volume 37
 medium delay volume 35
 standard delay volume 33
 status indicator 95
 stroke length 122
 stroke volume 14, 17
 system tool kit 196

T

temperature limit exceeded 115
 temperature out of range 114
 temperature sensor 105
 test functions 92
 tests
 pressure test results 129
 pressure test 128
 pump elasticity calibration 136
 solvent calibration 133
 solvent compressibility calibration 134
 system pressure test 128
 timeout 102
 troubleshooting
 error messages 92, 101
 status indicators 94, 92

U

unpacking the pump 30

V

vacuum degasser 10, 27, 61, 61
 operational hints 80
 when to use 80
 valve failed 111
 valve
 inlet valve, replacement 153
 solvent selection 177
 variable reluctance motor 14
 variable stroke volume 17
 voltage range 25

W

wash solvent 81
 waste
 electrical and electronic equipment 243
 WEEE directive 243
 weight 25
 wrong pump configuration 112

In This Book

This manual contains technical reference information about the Agilent 1260 Infinity Binary Pump G1312B. The manual describes the following:

- introduction,
- site requirements and specifications,
- installing the pump,
- using the binary pump,
- optimizing performance,
- troubleshooting and diagnostics,
- maintenance,
- parts and materials for maintenance,
- identifying cables,
- hardware information,
- appendix.

© Agilent Technologies 2005-2008, 2010-2013

Printed in Germany
11/2013



G1312-90015
Rev. B